

## ***BOLTED BONNET VALVE***

### **■ CAST STEEL VALVE**

- GATE VALVE
- Y-GLOBE VALVE
- SWING CHECK VALVE
- TILTING DISC CHECK VALVE
- DUAL PLATE CHECK VALVE

### **■ STAINLESS STEEL VALVE**

- GATE VALVE
- GLOBE VALVE
- SWING CHECK VALVE

# CAST STEEL VALVE

## SERVICE FEATURES

- Several trim combinations available for various services.
- Straight-through port design offering a good flow with minimum frictional loss and turbulence.
- Cast steel Valve suitable for works demanding strength, shock resistance, elongation and heat resistance.
- Bottom seating of seat rings ground accurately for maximum strength and tightness(globe).
- Bypass mounting to equalize pressures.
- Normal yoke bushing furnished with ductility resistant to high melting point of above 2200°F.
- Level and weight available to accelerate/decelerate disc closing (swing check).
- Designed for maximum flow with minimum pressure drop if possible.
- Precision-ground seating surfaces and revolving disc providing a long life.

In the refineries, power plants, utilities and petrochemical/chemical process industries, PK cast steel valve have been regarded as of great importance about their excellent performance and reliability.

By discriminatory blending of carefully selected materials combined with sound design and precision machining/assembly under strict quality controls, PK steel valve have gained general and wide acceptance. The products are manufactured in accordance with ASTM, ANSI, or other international standards.

## CAST STEEL VALVE PRODUCTION RANGE

UNIT : NPS

Type \ Class	150	300	600	900	1500	2500
GATE	2-∞	2-80	2-48	2-48	2-30	2-30
GLOBE	2-64	2-64	2-36	2-36	2-24	2-24
SWING CHECK	2-64	2-64	2-48	2-36	2-30	2-30
TILTING CHECK	2-64	2-64	2-48	2-36	2-30	2-30
Y-GLOBE	2-60	2-48	2-36	2-36	2-24	2-24
ANGLE GLOBE	2-24	2-24	2-24	2-24	2-24	2-24

## PRODUCTION MATERIALS

- Carbon Steel : ASTM A216-WCB or Equivalent
- Alloy Steel : ASTM A217-WC6, WC9, C5, C12, C12A or Equivalent
- Stainless Steel : ASTM A351-CF8, CF8M, CF3, CF3M, CN7M, or Equivalent
- Duplex Stainless Steel : ASTM A995-1A, 2A, 4A, 5A or Equivalent
- Special Alloy Steel : Inconel 625, Incoloy 825, Hastelloy C, Monel, AL-BRONZE
- ASME SA designation material(e.g ASME SA217-WC6)

# GATE VALVE

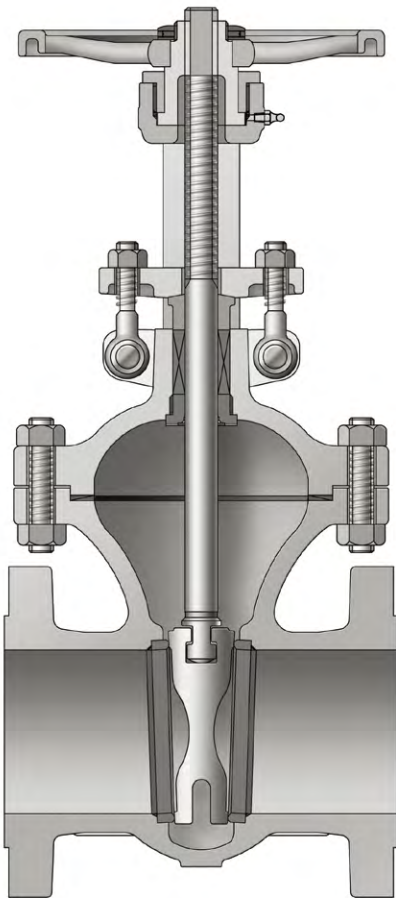

## FUNCTION

Gate valve is characterized by a sliding wedge which is moved by actuator perpendicular to the flow direction. There are a variety of valve sizes and types. The valve is used primarily as a stop valve to open or close fully. Normally it works for slurries, viscous fluid, etc., but not for throttling. The gate valve usually has a minimum pressure drop in full open and a tight seal in full close, and therefore there is little possibility that contaminants may enter the valve.

## BODY AND BONNET

The body and bonnet is designed to achieve most uniform distribution of stress on all sides and minimum turbulence and resistance to flow. The bonnet on valve is equipped with back seat ring up to 12" for Class 150 & 300 and up to 10" for Class 600 or higher. The yoke is integrated with bonnet.

## BODY-BONNET JOINT

Body-bonnet joint of gate valve is machined as follows:

Class 150 ..... Plain faced

Class 300 and higher class ..... Male and female

We can supply any kinds of gasket as required by customer.

## WEDGE

The valve is normally supplied with a one-piece flexible wedge of which the cross section is a tapered H shape.

All wedges are fully guided. The flexible wedge is cast or machined with circumferential grooves to allow the seating faces to move independently and adjust the movement of body seat.

It is used where the line load or thermal expansion of system may distort the seating face of valve, and especially useful to prevent sticking that may happen in case the valve is closed at a hot temperature and opened at a cold temperature.

Ideally the wedge is suitable for steam and other high temperature service.

## SEAT RING

The seat ring as a welded-in type is designed to prevent any turbulence and damage by corrosion. It is forged or rolled type into one piece for all dimensions, heat treated to obtain the desired surface hardness, and cleaned thoroughly before assembling.

## STEM

The stem connection to the wedge shall have an integrated tee head (without welding) and is rectified in the packing area to ensure a long life and perfect tightness. Through experiments, we have calculated and checked the connections between stem and wedge not to disengage the stem from wedge while gate valve is working.

The strength of stem and wedge connections is stronger than that of stem alone at the root of thread.

## PACKING

The packing size is designed to secure maximum tightness along the stem, and the standard packing is a non-asbestos type. We can supply any kinds of packing as required by customer.

## YOKE SLEEVE

The yoke sleeve is designed to be able to be disassembled without discounting bonnet and stem, and provided with ball bearing of 14" or over for Class 150 ~ 300 valve, 6" or over for Class 600, and 2" or over for Class 900 ~ 1500.

## GLAND

The gland is made of two pieces. Packing gland is in contact with the packing which is connected to gland flange through a spherical joint. Particular design permits a correct pressure on the packing without any damage to stem due to friction or corrosion.

## STUFFING BOX

The stuffing box gives maximum packing stem seal.

Lantern ring and grease injector shall be furnished only if specified on the purchase order.

## HAND WHEELS

Hand wheels are designed for easy operation. With gearing, motor actuator or cylinder actuator, it is also available for more difficult services.

## BOLTS AND NUTS

Bolts and nuts are made from four different types of steel materials in conformity with the ASTM specification:

1) A307 Grade B : It has a minimum tensile strength of 55,000 pounds per square inch (3870kg/mm<sup>2</sup>).

The nuts normally used with machine bolts are a hot pressed steel conforming to ASTM specification A307, which is usually applied to hinge bolts and nuts.

2) A193 Grade B7/B16 : It usually retains the strength well at an elevated temperature and offers higher resistance to creep than any other high grade steel used as bolting materials. This steel is regularly used in bonnet bolts.

3) A194 Grade 2H/4 : The nuts of this grade shall be re-heated above the critical range of steel, quenched in a suitable medium, and then tempered at a temperature not less than 850°F(455°C). This steel is regularly used in bonnet nuts.

4) Carbon steel : It is used in hand wheel nuts, set screws, or nipples.

## END CONNECTIONS

In our standard production of valve, the flange ends(RF.FF) and the face to face dimensions conform to ANSI B16.5 and ASME B16.10, respectively, and they have a raised face serrated finish type or other finish type as requested.

For butt-welded ends (B.W.), of which the end to end dimension conforms to ASME B16.10, customer must specify the schedule type required, pipe class, or bore diameter.

Ring type joint flanged ends (R.T.J) conform to ASME B16.5 and the end to end dimension follows ASME B16.10. The other special end connections may be supplied as required by customer.

## GEAR OPERATED VALVE

Valve can be supplied with gear operators.

## MOTOR OPERATED VALVE

Valve can be supplied with actuators, either electric or pneumatic, according to customer's requirements.

## ACCESSORIES

We can supply a valve fitted with accessories such as bypass, locking device, chain wheel, extension stem, etc. For more details, refer to the Accessories column.

## PACKING AND GASKET MATERIALS

Packing material supplied in standard valve is non-asbestos graphite, with braided graphite rings and die-formed rings configured to provide reliable and long-lasting performance. Braided rings are coated with zinc dust to inhibit corrosion.

Dieformed rings are 98% carbon(minimum)and have maximum 50PPM chloride 550PPM sulfur content.

For standard valve, gasket materials are as follows;

Class 150 - graphite sheet type with 304 stainless steel tanged insert. (1.6mm minimum overall thickness)

Class 300 - spiral wound 304 stainless steel and graphite.

Class 600 - same as class 300 or 900

Class 900 and 1500 - Ring type joint

## SEAL AREA DESIGN

Cast steel valve are designed and manufactured to satisfy strict requirements in order to prevent external leakage and to meet fugitive emission requirements of most customers.

Stuffing box finishes of 63 to 125 RMS, stem finishes of 16 to 32 RMS, control of straightness and concentricity of stems, and controlled diametrical clearances between stem and gland, stem and backseat, and gland and stuffing box, all combine to guarantee consistent performance of stem seals.

Gasket surfaces between bodies and bonnets are strictly controlled to finishes of 32 to 63 AARH. When combined with engineered bolting design, quality materials and strict assembly procedures, these finishes guarantee consistent sealing in gasket areas.

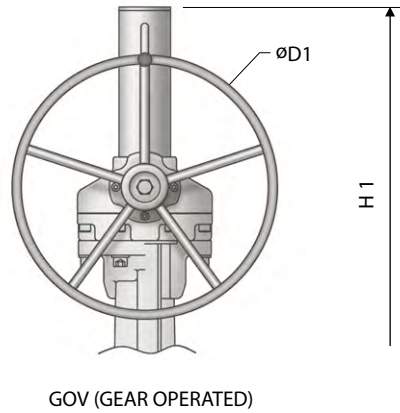
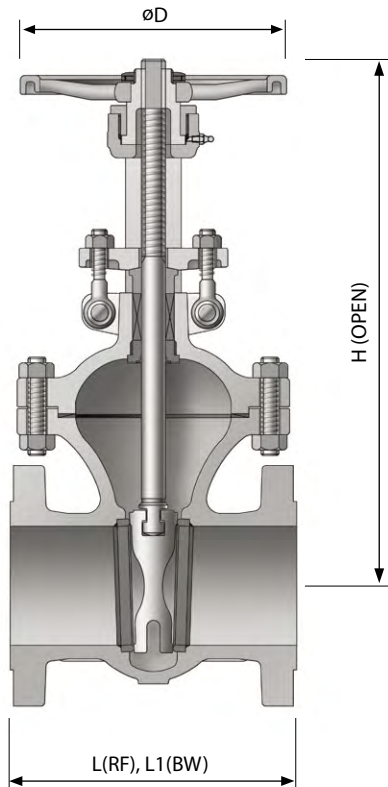

### END CONNECTION

- R.F FLANGED ENDS TO ASME B16.5
- B.W. ENDS TO ASME B16.25
- R.T.J FLANGED ENDS TO ASME B16.5
- SIZE 26" AND LARGER, FLANGED ENDS ACCORDING TO ASME B16.47 SER.A OR SER.B

### STANDARD MATERIAL SPECIFICATIONS

NO	PART NAME	MATERIAL		
1	BODY	A216 - WCB	A217 - WC6	A351 - CF8
2	BONNET	A216 - WCB	A217 - WC6	A351 - CF8
3	WEDGE	A217 - CA15 + STL	A217 - CA15 + STL	A351 - CF8 + STL
4	STEM	A479 - 410	A479 - 410	A479 - 304
5	HAND WHEEL	A197	A197	A197
6	BODY SEAT RING	A576 - 1020 + STL	A182 - F11 + STL	A240 - 304 + STL
7	BACK SEAT RING	A479 - 410	A479 - 410	A479 - 304
8	GASKET	SPIRAL WOUND / GRAPHITE+304+304		
9	PACKING	GRAPHITE+GRAPHITE WITH INCONEL WIRE		
10	GLAND FLANGE	A105	A105	A351 - CF8
11	HINGE BOLT	A307 - B	A307 - B	A193 - B8
12	HINGE NUT	A194 - 2H	A194 - 2H	A194 - 8
13	HINGE PIN	A576 - 1020	A576 - 1020	A479 - 304
14	PACKING GLAND	A576 - 1020 + Cr	A479 - 410	A479 - 304
15	BONNET BOLT	A193 - B7	A193 - B16	A193 - B8
16	BONNET NUT	A194 - 2H	A194 - 4	A194 - 8
17	YOKE CAP	A576 - 1020	A576 - 1020	A576 - 1020 + Zn
18	YOKE SLEEVE	A439 - D2C	A439 - D2C	A439 - D2C
19	HANDLE NUT	A47 - 32510 + Zn	A47 - 32510 + Zn	A47 - 32510 + Zn
20	SET SCREW	STEEL	STEEL	STEEL + Cr
21	NIPPLE	STEEL + Cr	STEEL + Cr	STEEL + Cr
22	GEAR BOX	DUCTILE IRON	DUCTILE IRON	DUCTILE IRON
23	STEM COVER	A53	A53	A53

## DIMENSION AND WEIGHT

### CLASS 150

UNIT: mm

SIZE	2	3	4	6	8	10	12	14	16	18	20	24	26	28	30
L	177.8	203.2	228.6	266.7	292.1	330.2	355.6	381.0	406.4	431.8	457.2	508.0	558.8	609.6	609.6
L1	215.9	282.4	304.8	403.4	419.1	457.2	501.7	571.5	609.6	660.4	711.2	812.8	-	-	-
D	200	224	250	315	355	400	450	500	560	630	710	800	-	900	900
D1	-	-	-	250	250	355	355	355	500	500	630	630	710	710	710
H	339	441	535	735	927	1125	1317	1550	1823	1900	2120	2502	-	2873	3066
H1	-	-	-	950	1071	1260	1462	1658	1830	2058	2268	2660	2950	3052	3268
WEIGHT(Kg)	16	29	43	72	116	173	263	388	535	648	822	1276	1552	1777	2119

### CLASS 300

UNIT: mm

SIZE	2	3	4	6	8	10	12	14	16	18	20	24	26	28	30
L	215.9	282.4	304.8	403.4	419.1	457.2	501.7	762.0	838.2	914.4	990.6	1143.0	1244.6	1346.2	1397
L1	215.9	282.4	304.8	403.4	419.1	457.2	501.7	762.0	838.2	914.4	990.6	1143.0	-	-	-
D	200	224	250	355	400	450	500	560	630	710	800	900	-	-	-
D1	-	-	-	250	355	355	355	500	500	630	630	710	800	800	900
H	340	442	536	745	951	1142	1325	1631	1692	1909	2119	2492	-	-	-
H1	-	-	-	895	1087	1269	1470	1669	1849	2065	2272	2667	3057	3265	3475
WEIGHT(Kg)	22	41	59	119	193	291	410	687	876	1201	1500	2258	3026	3450	4147

### CLASS 600

UNIT: mm

SIZE	2	3	4	6	8	10	12	14	16	18	20	24	26	28	30
L	292.1	355.6	431.8	558.8	660.4	787.4	838.2	889.0	990.6	1092.2	1193.8	1397.0	1447.8	1549.4	1651
L1	292.1	355.6	431.8	558.8	660.4	787.4	838.2	889.0	990.6	1092.2	1193.8	1397.0	-	-	-
D	200	250	355	450	500	630	-	-	-	-	-	-	-	-	-
D1	-	-	-	355	500	500	630	630	710	710	800	900	900	900	900
H	394	475	591	801	1005	1192	-	-	-	-	-	-	-	-	-
H1	-	-	-	995	1233	1360	1605	1792	2079	2160	2366	2740	3002	3235	3480
WEIGHT(Kg)	35	64	110	222	405	626	878	1165	1490	1836	2410	3639	4437	5589	6933

### CLASS 900

UNIT: mm

SIZE	2	3	4	6	8	10	12	14	16	18	20	24
L	368.3	381.0	457.2	609.6	736.6	838.2	965.2	1028.7	1130.3	1219.2	1320.8	1549.4
L1	368.3	381.0	457.2	609.6	736.6	838.2	965.2	1028.7	1130.3	1219.2	1320.8	1549.4
D	250	355	355	500	630	710	-	-	-	-	-	-
D1	-	250	250	500	500	630	710	710	710	900	900	900
H	474	623	718	958	1290	1451	-	-	-	-	-	-
H1	-	678	900	1112	1322	1542	1786	1792	1955	2308	2466	2889
WEIGHT(Kg)	73	103	159	318	568	908	1234	1628	2288	3025	3850	5200

### CLASS 1500

UNIT: mm

SIZE	2	3	4	6	8	10	12	16
L	368.3	469.9	546.1	704.9	831.9	990.6	1130.3	1384.4
L1	368.3	469.9	546.1	704.9	831.9	990.6	1130.3	-
D	250	355	400	560	800	900	-	1092
D1	-	-	355	500	630	710	800	800
H	474	603	730	944	1205	1414	-	2129
H1	-	-	880	1106	1350	1570	1826	2341
WEIGHT(Kg)	81	141	227	515	992	1603	2572	5255

# GLOBE VALVE

## FUNCTION

The globe valve is used where throttling alone or both throttling and shutoff is needed. It may also be used for on-off service, but because of high pressure drop, such application is limited to the cases that the valve is normally closed and the pressure drop is of no importance in valve open condition.

PK cast steel globe valve is regularly made in outside screw and yoke design with full-way type disc.

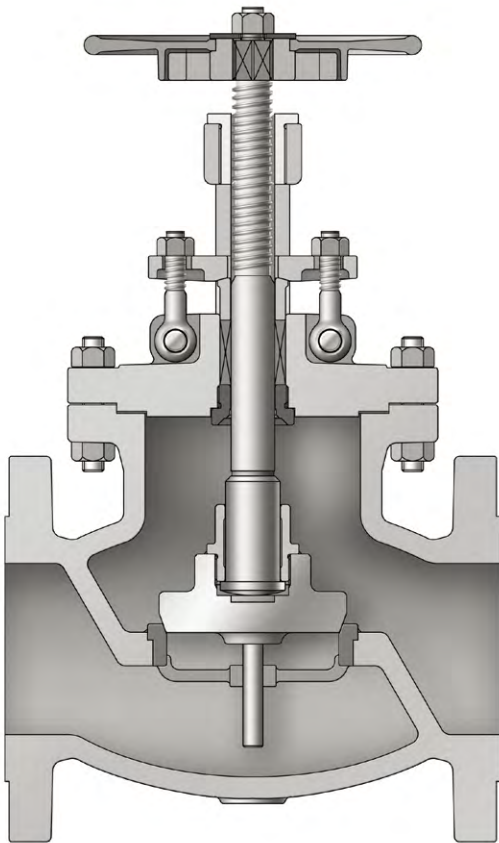

## BODY AND BONNET

The body has a spherical form with large radius, which permits the stress, turbulence and resistance to flow to be kept minimum. The bonnets on valve are equipped with back seat rings.

## BODY-BONNET JOINT

Body-bonnet joint of globe valve is machined as follows:

All ..... Male and female.

We can supply any kinds of gasket as required by customer.

## DISC

The valve is normally supplied with plug type disc.

## SEAT RING

The valve is normally supplied with bottom seated type on 8" or larger valve, and the disc has bottom guide type seat rings.

## STEM

All stem have the turning and rising cut ACME threads.



## YOKE BUSH

The yoke nuts on globe valve are threaded and mounted to the bonnet, where it is secured with tack welding.

## PACKING

The packing size is designed to secure maximum tightness along the stem, and the standard packing is a non-asbestos type. We can supply any kinds of packing as required by customer.

## GLAND

The gland is made of two pieces. Packing gland is in contact with the packing which is connected to gland flange through a spherical joint. Particular design permits a correct pressure on the packing without any damage to stem due to friction or corrosion.

## STUFFING BOX

The stuffing box gives maximum packing stem seal. Lantern ring and grease injector shall be furnished only if specified on the purchase order.

## HAND WHEELS

Hand wheels are designed for easy operation. They are provided with hammer blow type of 8" and over for Class 150 valve, 6" and over for Class 300 and, 4" and over for Class 600, and 2.5" and over for Class 900 & 1500. With gearing, motor actuator or cylinder actuator, they are also available for more difficult services.



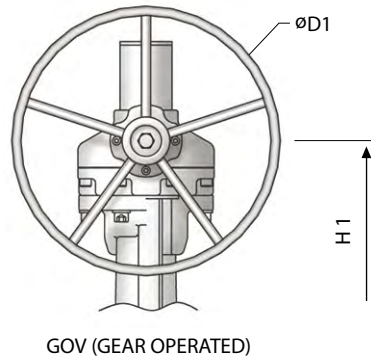
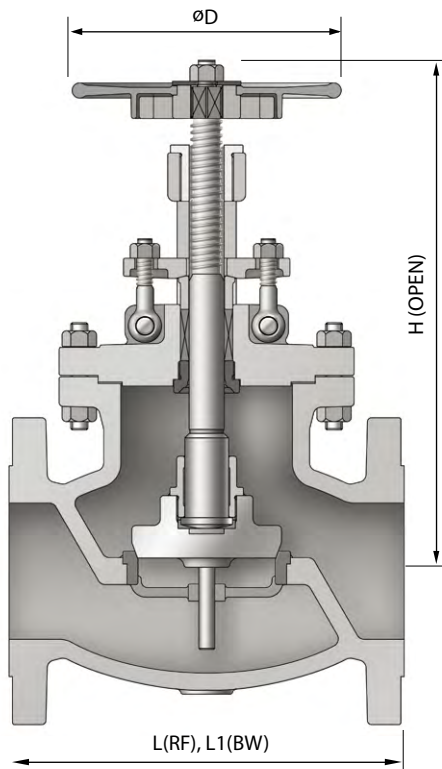

### END CONNECTION

- R.F FLANGED ENDS TO ASME B16.5
- B.W. ENDS TO ASME B16.25
- R.T.J FLANGED ENDS TO ASME B16.5
- SIZE 26" AND LARGER, FLANGED ENDS ACCORDING TO ASME B16.47 SER.A OR SER.B

### STANDARD MATERIAL SPECIFICATIONS

NO.	PART NAME	MATERIAL		
1	BODY	A216 - WCB	A217 - WC6	A351 - CF8M
2	BONNET	A216 - WCB	A217 - WC6	A351 - CF8M
3	DISC	A217 - CA15+STL	A217 - CA15+STL	A351 - CF8+STL
4	STEM	A479 - 410	A479 - 410	A479 - 304
5	HAND WHEEL	DUCTILE IRON	DUCTILE IRON	DUCTILE IRON
6	BODY SEAT RING	A216 - WCB+STL	A217 - WC6+STL	A351 - CF8+STL
7	BACK SEAT RING	A479 - 410	A479 - 410	A479 - 304
8	GASKET	SPIRAL WOUND / GRAPHITE+304+304		
9	PACKING	GRAPHITE+GRAPHITE WITH INCONEL WIRE		
10	GLAND FLANGE	A283 - D	A283 - D	A351 - CF8
11	HINGE BOLT	A307 - B	A307 - B	A193 - B8
12	HINGE NUT	A194 - 2H	A194 - 2H	A194 - 8
13	HINGE PIN	A576 - 1020	A576 - 1020	A479 - 304
14	PACKING GLAND	A576 - 1020+Cr	A479 - 410	A479 - 304
15	BONNET BOLT	A193 - B7	A193 - B16	A193 - B8
16	BONNET NUT	A194 - 2H	A194 - 4	A194 - 8
17	YOKE BUSH	A439 - D2C	A439 - D2C	A439 - D2C
18	LOCK NUT	A479 - 410	A479 - 410	A479 - 304
19	HANDLE NUT	A563 - A	A563 - A	A194 - 8
21	SHAKE ADAPTER	DUCTILE IRON	DUCTILE IRON	DUCTILE IRON
22	HANDLE COVER	A283 - D	A283 - D	A283 - D
23	GEAR BOX	DUCTILE IRON	DUCTILE IRON	DUCTILE IRON
24	STEM COVER	A53	A53	A53

## DIMENSION AND WEIGHT

### CLASS 150

UNIT :mm

SIZE	2	3	4	6	8	10	12	14	16	18	20	24
L	203.2	241.3	292.1	406.4	495.3	622.3	698.5	787.4	914.4	978.0	978.0	1295.4
L1	203.2	241.3	292.1	406.4	495.3	622.3	698.5	787.4	914.4	978.0	-	-
D	200	250	315	355	355	400	400	-	-	-	-	-
D1	-	-	-	-	450	450	500	560	630	630	800	800
H	284	344	388	505	623	805	839	-	-	-	-	-
H1	-	-	-	-	577	626	800	922	980	1140	1825	2029
WEIGHT(Kg)	14	27	43	91	178	256	409	616	825	960	1387	1988

### CLASS 300

UNIT :mm

SIZE	2	3	4	6	8	10	12	16	18	20	24	28
L	266.7	317.5	355.6	444.5	558.8	622.3	711.2	863.6	914.4	1016.0	1346.2	1498.6
L1	266.7	317.5	355.6	444.5	558.8	622.3	711.2	863.6	-	-	-	-
D	200	250	315	355	400	450	500	-	-	-	-	-
D1	-	-	-	-	500	560	630	710	710	800	800	800
H	286	346	392	618	793	1145	1260	-	-	-	-	-
H1	-	-	-	-	805	880	971	1120	1220	1674	2086	2338
WEIGHT(Kg)	20	37	58	140	260	422	567	975	1700	2090	3481	4590

### CLASS 600

UNIT :mm

SIZE	2	3	4	6	8	10	12	14	16	18	20	24	30
L	292.1	355.6	431.8	558.8	660.4	787.4	838.2	889.0	990.6	1092.2	1193.8	1397.0	1651.0
L1	292.1	355.6	431.8	558.8	660.4	787.4	838.2	-	-	-	-	-	-
D	224	315	315	450	-	-	-	-	-	-	-	-	-
D1	-	-	-	500	560	630	800	800	800	800	800	800	800
H	392	478	531	675	-	-	-	-	-	-	-	-	-
H1	-	-	-	689	754	959	1690	1871	2015	2449	2504	2595	3237
WEIGHT(Kg)	35	63	120	233	415	652	1316	1565	2120	3110	3490	4320	10800

### CLASS 900

UNIT :mm

SIZE	2	3	4	6	8	12	14
L	368.3	381.0	457.2	609.6	736.6	965.2	1029
L1	368.3	381.0	457.2	609.6	736.6	965.2	-
D	315	315	355	450	710	-	900
D1	-	-	400	560	630	710	-
H	498	513	605	730	894	-	1913
H1	-	-	600	710	970	1101	-
WEIGHT(Kg)	77	103	177	388	655	1288	1500

### CLASS 1500

UNIT :mm

SIZE	2	3	4	6	8	14
L	368.3	469.9	546.1	704.9	831.9	990.6
L1	368.3	469.9	546.1	704.9	831.9	990.6
D	315	355	400	500	800	-
D1	-	-	400	630	710	800
H	497	584	714	1065	1191	-
H1	-	-	700	1105	1100	1206
WEIGHT(Kg)	77	147	262	669	1187	1827

# Y-GLOBE VALVE

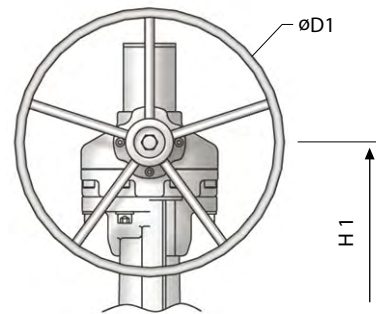
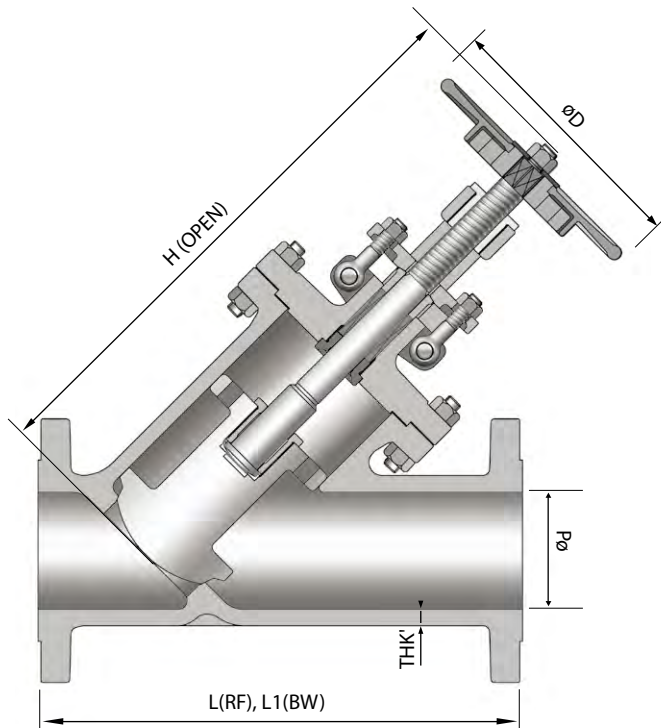

GOV (GEAR OPERATED)

## NOTE

- DESIGN : ASME B16.34 & BS1873
- FACE TO FACE DIMENSION : ASME B16.10
- END FLANGE DIMENSION : ASME B16.5  
SIZE 26" & LARGER : ASME B16.47
- PRESSURE TEST : API 598

## STANDARD MATERIAL SPECIFICATIONS

NO.	PART NAME	MATERIAL		
1	BODY	A216 - WCB	A217 - WC6	A351 - CF8
2	BONNET	A216 - WCB	A217 - WC6	A351 - CF8
3	DISC	A217 - CA15+STL	A217 - CA15+STL	A351 - CF8+STL
4	STEM	A479 - 410	A479 - 410	A479 - 304
5	HAND WHEEL	DUCTILE IRON	DUCTILE IRON	DUCTILE IRON
6	BODY SEAT	A216 - WCB+STL	A217 - WC6+STL	A351 - CF8+STL
7	BACK SEAT RING	A479 - 410	A479 - 410	A479 - 304
8	GASKET	SPIRAL WOUND / GRAPHITE+304+304		
9	PACKING	GRAPHITE+GRAPHITE WITH INCONEL WIRE		
10	GLAND FLANGE	A283 - D	A283 - D	A351 - CF8
11	HINGE BOLT	A307 - B	A307 - B	A193 - B8
12	HINGE NUT	A194 - 2H	A194 - 2H	A194 - 8
13	HINGE PIN	A576 - 1020	A576 - 1020	A479 - 304
14	PACKING GLAND	A576 - 1020+Cr	A479 - 410	A479 - 304
15	BONNET BOLT	A193 - B7	A193 - B16	A193 - B8
16	BONNET NUT	A194 - 2H	A194 - 4	A194 - 8
17	YOKE BUSH	A439 - D2C	A439 - D2C	A439 - D2C
18	LOCK NUT	A479 - 410	A479 - 410	A479 - 304
19	HANDLE NUT	A563 - A	A563 - A	A194 - 8
21	SHAKE ADAPTER	DUCTILE IRON	DUCTILE IRON	DUCTILE IRON
22	HANDLE COVER	A283 - D	A283 - D	A283 - D
23	GEAR BOX	DUCTILE IRON	DUCTILE IRON	DUCTILE IRON
24	STEM COVER	A53	A53	A53

## DIMENSION AND WEIGHT

### CLASS 150

UNIT : mm

SIZE	2	4	6	8	12	14
L	228.6	368.3	470.0	596.9	-	787.4
L1	228.6	368.3	470.0	596.9	775.0	787.4
D	200	315	355	355	-	-
D1	-	-	-	450	500	560
H	353	491	644	803	-	-
H1	-	-	-	757	980	1185
d	50.8	101.6	152.4	203.2	304.8	336.6
THK'	8.6	11.2	11.9	12.7	16.1	17.0

### CLASS 300

UNIT : mm

SIZE	2	2 1/2	3	4	6	8	10	12	14
L	266.7	292.1	317.5	355.6	444.5	558.8	622.3	711.2	838.2
L1	266.7	292.1	317.5	355.6	444.5	558.8	622.3	711.2	838.2
D	200	224	250	315	355	400	450	-	-
D1	-	-	-	-	-	500	560	630	630
H	355	385	465	467	774	1006	1367	-	-
H1	-	-	-	-	-	1018	1102	1264	1326
d	50.8	63.5	76.2	101.6	152.4	203.2	254.0	304.8	336.6
THK'	9.7	11.2	11.9	12.7	16.0	17.5	19.2	20.7	23.0

### CLASS 600

UNIT : mm

SIZE	3	4	8	16	20
L	355.6	431.8	660.4	990.6	1193.8
L1	355.6	431.8	660.4	-	-
D	315	315	-	-	-
D1	-	-	560	900	900
H	578	669	-	-	-
H1	-	-	1075	1637	2158
d	76.2	101.6	200.0	374.7	463.6
THK'	13.2	16.0	25.6	38.5	45.0

# SWING CHECK VALVE

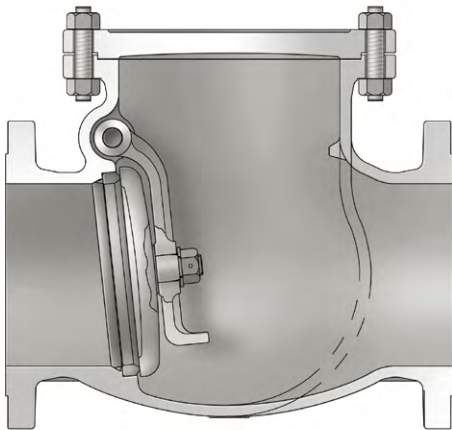
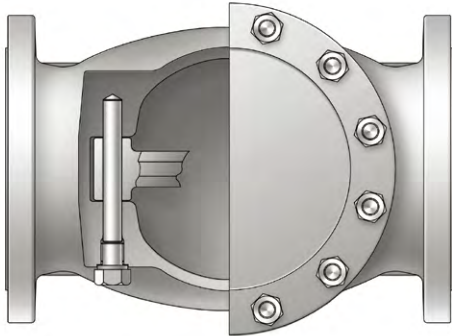

## FUNCTION

The swing check valve is designed so that it is opened automatically at the forward flow and closed at the reverse flow in horizontal or vertical (upward flow only through valve) piping runs. It has an advantage of low pressure drop and therefore is best suitable for velocity application.

## BODY

The body has a spherical form with large radius, which permits the stress, turbulence and resistance to flow to be kept minimum.

## BODY-COVER JOINT

Body-cover joint of swing check valve is machined as follows:

Class 150 .....Male and female.

Class 300 and 600 ..... Male and female.

Class 900 higher class ..... Ring type joint.

We can supply any kinds of gasket as required by customer.

## SEAT RING

The seat ring as a welded-in type is designed to prevent any turbulence and damage by corrosion. It is forged or rolled into one piece for all dimensions, heat treated to obtain the desired surface hardness, and cleaned thoroughly before assembling.

## END CONNECTIONS

In our standard production of valve, the flange ends (RF) and the face to face dimensions conform to ANSI B16.5 and ASME B16.10, respectively, and they have a raised face serrated finish type or other finish type as requested.

For butt-welded ends (B.W), of which the end to end dimension conforms to ASME B16.10, customer must specify the schedule type required, pipe class, or bore diameter.

Ring joint flanged ends (R.T.J) conform to ASME B16.5 and the end to end dimension follows ASME B16.10. The other special end connections may be supplied as required by customer.

## HINGE ARRANGEMENT

- Body penetration is sealed with blind flange and spiral-wound gasket
- Arm pin is located near the disc center of gravity, minimizing sealing surface radius rotation and thus velocity.

## ARM ARRANGEMENT

- Hydrofoil profile maintains the disc stability while being lifted by a hydrodynamic force at a flow including pulsating.
- Heavy-balanced weight insures that disc goes to seat immediately upon cessation of flow and minimizes water hammer.

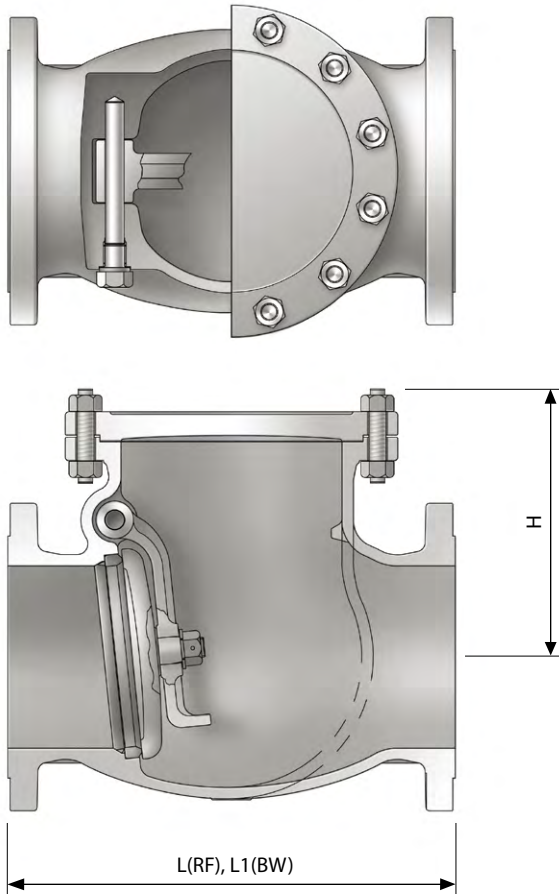

### END CONNECTION

- R.F FLANGED ENDS TO ASME B16.5
- B.W. ENDS TO ASME B16.25
- R.T.J FLANGED ENDS TO ASME B16.5
- SIZE 26" AND LARGER, FLANGED ENDS ACCORDING TO ASME B16.47 SER.A OR SER.B

### STANDARD MATERIAL SPECIFICATIONS

NO.	PART NAME	MATERIAL		
1	BODY	A216 - WCB	A217 - WC6	A351 - CF8
2	BONNET	A216 - WCB	A217 - WC6	A351 - CF8
3	DISC	A217 - CA15+STL	A217 - CA15+STL	A351 - CF8+STL
4	ARM	A216 - WCB	A216 - WC6	A351 - CF8
5	ROD PIN	A479 - 410	A479 - 410	A479 - 304
6	BODY SEAT RING	A576 - 1020+STL(S20C)	A182 - F11+STL	A240 - 304+STL
7	PLUG BOLT	A307 - B	A479 - 304	A479 - 304
8	GASKET	SPIRAL WOUND / GRAPHITE+304+304		
9	PLUG GASKET	SOFT STEEL	304 S.S	304 S.S
10	BONNET BOLT	A193 - B7	A193 - B16	A193 - B8
11	BONNET NUT	A194 - 2H	A194 - 4	A194 - 8
12	DISC NUT	A194 - 8	A194 - 8	A194 - 8
13	PIN	304 S.S	304 S.S	304 S.S
14	WASHER	304 S.S	304 S.S	304 S.S

## INTERNAL TYPE SW-CH VALVE

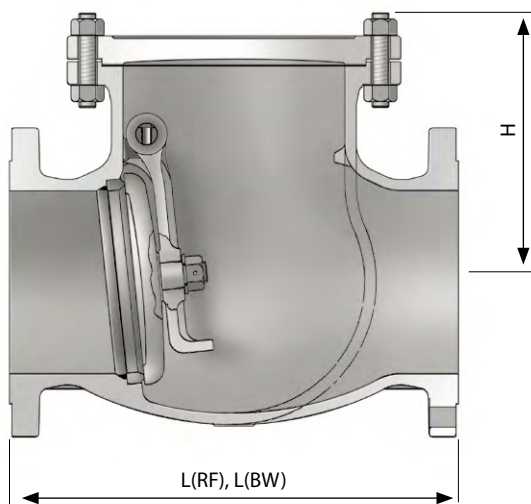
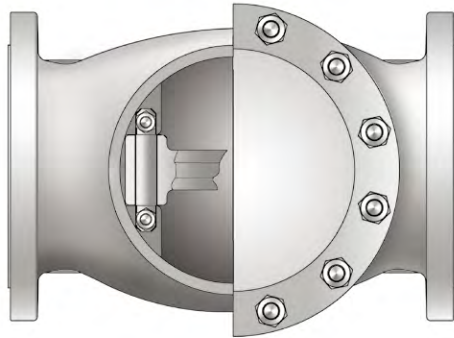

### END CONNECTION

- R.F FLANGED ENDS TO ASME B16.5
- B.W. ENDS TO ASME B16.25
- R.T.J FLANGED ENDS TO ASME B16.5
- SIZE 26" AND LARGER, FLANGED ENDS ACCORDING TO ASME B16.47 SER.A OR SER.B

### STANDARD MATERIAL SPECIFICATIONS

NO.	PART NAME	MATERIAL		
1	BODY	A216 - WCB	A217 - WC6	A351 - CF8
2	COVER	A216 - WCB	A217 - WC6	A351 - CF8
3	DISC	A217 - CA15+STL	A217 - CA15+STL	A351 - CF8+STL
4	ARM	A216 - WCB	A217 - WC6	A351 - CF8
5	ROD PIN	A479 - 410	A479 - 410	A479 - 304
6	BODY SEAT RING	A576 - 1020+STL	A182 - F11+STL	A240 - 304+STL
7	INTERNAL BOLT	A193 - B8	A193 - B8	A193 - B8
8	INTERNAL NUT	A194 - 8	A194 - 8	A194 - 8
9	WASHER	316 S.S	316 S.S	316 S.S
10	GASKET	SPIRAL WOUND / GRAPHITE+304+304		
11	BONNET BOLT	A193 - B7	A193 - B16	A193 - B8
12	BONNET NUT	A194 - 2H	A194 - 4	A194 - 8
13	DISC NUT	A194 - 8	A194 - 8	A194 - 8
14	PIN	304 S.S	304 S.S	304 S.S
15	PLAIN WASHER	304 S.S	304 S.S	304 S.S



## DIMENSION AND WEIGHT

### CLASS 150

UNIT : mm

SIZE	2	3	4	6	8	10	12	14	16	18	20	24	26	28	30
L	203.2	241.3	292.1	355.6	495.3	622.3	698.5	787.4	863.6	977.9	977.9	1295.4	1295.4	1447.8	1524
L1	203.2	241.3	292.1	355.6	495.3	622.3	698.5	787.4	863.6	977.9	977.9	1295.4	-	-	-
H	160	190	225	260	320	350	380	405	460	505	570	680	865	918	962
WEIGHT(kg)	16	26	45	78	136	214	319	412	514	749	933	1346	1727	1964	2247

### CLASS 300

UNIT : mm

SIZE	2	3	4	6	8	10	12	14	16	18	20	24	26	28	30
L	266.7	317.5	355.6	444.5	533.4	622.3	711.2	838.2	863.6	977.9	1016.0	1346.2	1346.2	1498.6	1593.9
L1	266.7	317.5	355.6	444.5	533.4	622.3	711.2	838.2	863.6	977.9	1016.0	1346.2	-	-	-
H	160	199	227	278	322	383	435	510	521	572	622	712	979	983	1115
WEIGHT(kg)	21	42	54	124	222	291	444	632	786	1058	1210	1916	2000	2600	3664

### CLASS 600

UNIT : mm

SIZE	2	3	4	6	8	10	12	14	16	18	20	24	26	30
L	292.1	355.6	431.8	558.8	660.4	787.4	838.2	889.0	990.6	1092.2	1193.8	1397.0	-	1651
L1	292.1	355.6	431.8	558.8	660.4	787.4	838.2	889.0	990.6	1092.2	1193.8	1397.0	1448	-
H	197	210	256	329	364	464	486	572	660	711	787	864	1028	1135
WEIGHT(kg)	31	56	103	204	342	624	776	938	1250	1518	2390	3686	4000	5502

### CLASS 900

UNIT : mm

SIZE	2	3	4	6	8	10	12	14	16	18	20	24
L	368.3	381.0	457.2	609.6	736.6	838.2	965.2	1028.7	1130.3	1219.2	1320.8	1549.4
L1	368.3	381.0	457.2	609.6	736.6	838.2	965.2	1028.7	1130.3	1219.2	1320.8	1549.4
H	267	290	306	338	460	500	578	647	710	785	850	1006
WEIGHT(kg)	68	106	139	294	525	731	1025	1444	1850	2610	3407	5842

### CLASS 1500

UNIT : mm

SIZE	2	3	4	6	8	10	12	16
L	368.3	469.9	546.1	704.9	831.9	990.6	1130.3	1384.3
L1	368.3	469.9	546.1	704.9	831.9	990.6	1130.3	1384.3
H	267	296	355	465	540	657	728	1116
WEIGHT(kg)	73	125	212	470	825	960	1510	4630

## TILTING DISC CHECK VALVE

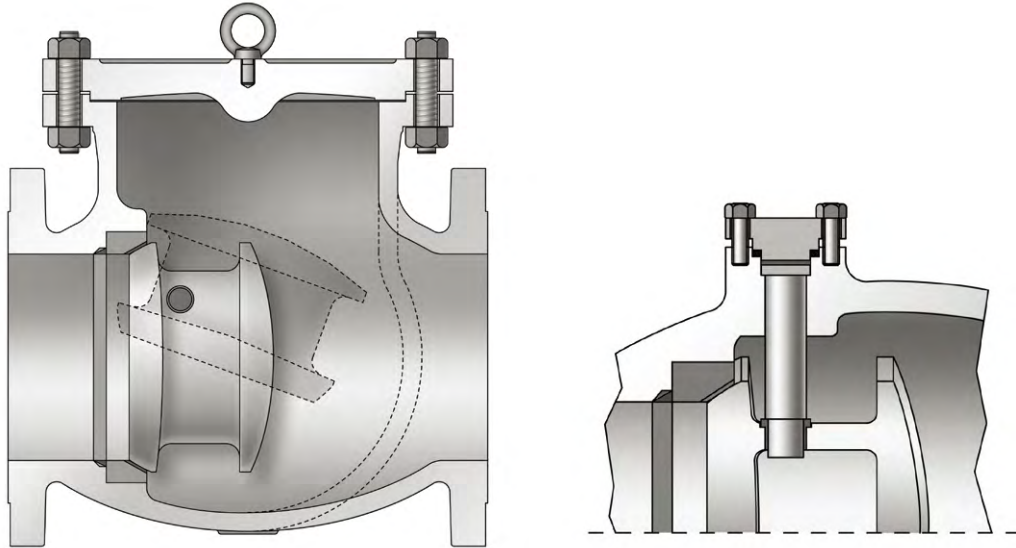

### FUNCTION

Today, higher velocity and pressure of piping often requires a sophisticated check valve rather than conventional swing type valve. PK tilting disc check valve is designed to handle such higher velocities, prevent damages due to turbulence and avoid “water hammer” phenomenon in piping systems, and it is closed quickly and quietly. The valve is closed quickly because its pivot(hinge pins) is shut by a very small arc. Moreover, line fluid flows both over and under the disc, so that valve closing is cushioned by the line fluid itself. By virtue of quick and quiet closing ability, up to now PK tilting disc check valve has earned good reputation as a “non-slam” check valve.

### BODY

Body-cover joint of swing-check valve are machined as follows:

Class 150 ..... Male and female.

Class 300 and 600 ..... Male and female.

Class 900 and 1500 ..... Ring type joint.

We can supply any kind of gasket per customer requirements.

### SEAT RING

Seat rings are welded into valve bodies in order to prevent turbulence and avoid damage due to corrosion seats, forged or rolled in one piece for all dimensions, heat treated to obtain the required surface hardness, and perfectly cleaned before assembly.

### END CONNECTIONS

Our standard production covers valve with;

FLANGED ENDS(RF) that conform to ASME B16.5 and face to face dimensions that conform to ASME B16.10, with a raised face serrated finish or, on request, with any other finish;

BUTT-WELDING ENDS(B.W) with end to end dimensions that conform to ASME B16.10;

(Customer must specify the schedule required, or class of pipe, or diameter and bore.)

RING JOINT FLANGED ENDS(R.T.J) that conform to ASME B16.5 and with end to end dimensions to ASME B16.10; Other special end connections are supplied to customer requirements.

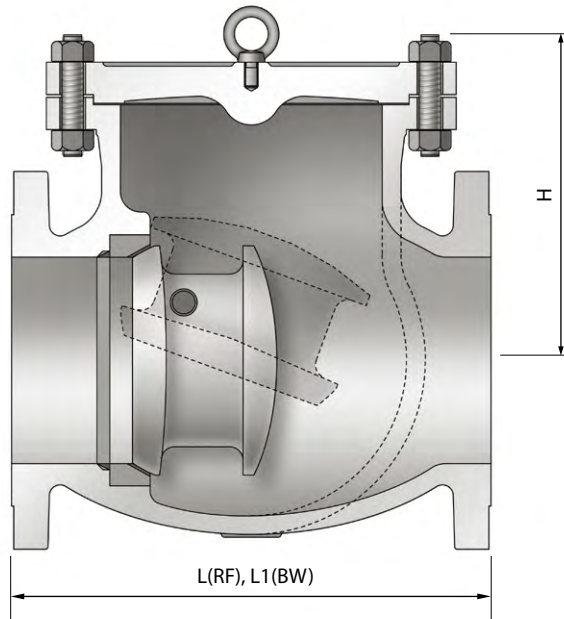

### END CONNECTION

- R.F FLANGED ENDS TO ASME B16.5
- B.W. ENDS TO ASME B16.25
- R.T.J FLANGED ENDS TO ASME B16.5
- SIZE 26" AND LARGER, FLANGED ENDS ACCORDING TO ASME B16.47 SER.A OR SER.B

### STANDARD MATERIAL SPECIFICATIONS

NO.	PART NAME	MATERIAL		
1	BODY	A216 - WCB	A217 - WC6	A351 - CF8
2	BONNET	A216 - WCB	A217 - WC6	A351 - CF8
3	DISC	A216 - WCB+STL	A217 - WC6+STL	A351 - CF8+STL
4	BODY SEAT RING	A576 - 1020+STL(S20C)	A182 - F11+STL	A240 - 304+STL
5	GASKET	SPIRAL WOUND / GRAPHITE+304+304		
6	HINGE PIN	A479 - 410	A479 - 410	A479 - 304
7	BUSHING	A479 - 304	A479 - 304	A479 - 304
8	BONNET BOLT	A193 - B7	A193 - B16	A193 - B8
9	BONNET NUT	A194 - 2H	A194 - 4	A194 - 8
10	COVER	A576 - 1020	A240 - 304	A240 - 304
11	COVER BOLT	A193 - B7	A193 - B7	A193 - B8
12	COVER NUT	A194 - 2H	A194 - 2H	194 - 8
13	COVER GASKET	SPIRAL WOUND / GRAPHITE+304		
14	EYE BOLT	A307 - B	A307 - B	A307 - B+Cr

## DIMENSION AND WEIGHT

### CLASS 150

UNIT : mm

SIZE	2	3	4	6	8	10	12	14	16	18	20	24	26	30
L	203.2	241.3	292.1	355.6	495.3	622.3	698.5	787.4	863.6	977.9	977.9	1295.4	1295.4	1524
L1	203.2	241.3	292.1	355.6	495.3	622.3	698.5	787.4	863.6	977.9	977.9	1295.4	-	-
H	152	190	195	242	298	320	384	381	465	517	579	597	820	970
WEIGHT(kg)	19	31	54	94	163	257	383	494	617	899	1120	1615	2072	2696

### CLASS 300

UNIT : mm

SIZE	2	3	4	6	8	10	12	14	16	18	20	24	26	28
L	266.7	317.5	355.6	444.5	533.4	622.3	711.2	838.2	863.6	977.9	1016.0	1346.2	1346.2	1498.6
L1	266.7	317.5	355.6	444.5	533.4	622.3	711.2	838.2	863.6	977.9	1016.0	1346.2	-	-
H	163	202	205	331	298	345	425	490	494	554	578	690	909	977
WEIGHT(kg)	25	50	77	149	266	349	533	758	943	1270	1452	2299	2400	3120

### CLASS 600

UNIT : mm

SIZE	2	3	4	6	8	10	14	16	18	20	26	28	30
L	292.1	355.6	431.8	558.8	660.4	787.4	889.0	990.6	1092.2	1193.8	1447.8	1600.2	1651
L1	292.1	355.6	431.8	558.8	660.4	787.4	889.0	990.6	1092.2	1193.8	-	-	-
H	170	190	225	305	379	466	520	534	697	695	1216	1176	1306
WEIGHT(kg)	37	67	124	245	410	749	1126	1500	1822	2868	5560	5810	7150

### CLASS 900

UNIT : mm

SIZE	3	4	6	8	10	16
L	381.0	457.2	609.6	736.6	838.2	1130.3
L1	381.0	457.2	609.6	736.6	838.2	1130.3
H	288	292	378	448	510	948
WEIGHT(kg)	127	167	353	530	877	2220

### CLASS 1500

UNIT : mm

SIZE	2	3	4	6	8	10	12	14	16
L	368.3	469.9	546.1	704.9	831.9	990.6	1130.3	1257.3	1384.3
L1	368.3	469.9	546.1	704.9	831.9	990.6	1130.3	1257.3	1384.3
H	260	288	350	434	512	633	722	873	948
WEIGHT(kg)	88	150	254	564	990	1152	1812	3582	5556

# DUAL PLATE CHECK VALVE

## TYPICAL CONSTRUCTIONS

Dual plate check valve are supplied retainerless as standard. Our patented design does not have any threaded plugs in the pressure boundary and totally eliminates the potential leakpath to atmosphere. This design meet fugitive emission control.

## VALVE FEATURES & ADVANTAGES

- Dual plate Check Valve is economical on installation and maintenance because installation is required less and light weight.
- Dual plate Check Valve is possible to prevent water hammering due to closing valve disk by operating the spring in valve before back flow. Also Due-Check valve prevents large piping the for big gap water levels.
- Dual plate Check Valve can apply variously in piping line because of less than existing Check Valve on restrictions of instaling direction.
- Life spans is longer than existing Check Valve, And preservation and repair are simple.
- It's possible to reduce maintenance fee due to longer durability than existing check valve, easy maintenance.

RANGE		APPLICATION
NORMINAL SIZE		1 1/2"(40A) - 84"(2100A)
FLUID		Water, Air, Steam, Gas, Sea Water
RATING		JIS 10K, 20K, 30K, ANSI 150#, 300#, 600#, 900#, 1500#, PN 10, 16, 20, 40, AWWA C 207
END CONNECTION		Wafer, Lugged, Flanged
TEMP. RANGE		-50 ~ 600°C
MATERIAL	BODY	A126-CLB, A536 Gr. Carbon Steel (A216-WCB etc.) Stainless Steel (CF8, CF8M, CF3 etc.) B148-C97800, Special Steel (Alloy etc.)
	DISC	Carbon Steel (A216-WCB etc.) Stainless Steel (CF8, CF8M, CF3 etc.) B148-C95800, Special Steel (Alloy etc.)
	SEAT	Rubber (EPDM, Buna-N etc.) Metal (Stainless Steel, Stellite #6 etc.)
	SPRING	Stanless Steel (304, 316 etc) Inconel (625, X750 etc)

## MATERIAL TEMPERATURE LIMITS

### UPPER TEMPERATURE LIMITS

MATERIAL	UPPER LIMIT F(°C)
316SS	250(121)
INCONEL X 750	1000(537)
MONEL	400(204)
HASTELLOY	800(426)
ALLOY20	250(121)
BUNA-N(NBR)	250(121)
EPDM	300(149)
PTFE	450(232)
METAL OVELAY	AS BODY
METAL TO METAL	AS BODY

### LOWER TEMPERATURE LIMITS

MATERIAL	LOWER LIMIT F(°C)
WCB	-20(-28.9)
LCC	-50(-45.6)
CF8M	-450(-268)
BUNA-N(NBR)	-70(-56.7)
EPDM	-14(-11.4)
VITON	-40(-40)
PTFE	-200(-129)
METAL TO METAL	AS BODY

## STANDARD DESIGN

### WAFER TYPE

Retainerless design supplied as standard

- **ANSI B16.5**
  - Flange dims to ANSI B16.5 (MSS-SP44>24")
  - Face to face dims to API 594
- **API 605**
  - Flange dims to API 605
  - Face to face dims to API 594

### FLANGED TYPE

- Flange dims to ANSI B16.5 (MSS-SP44>24")
- Face to face dims to API 594

- **API 6A**
  - Flange dims to API 6A
  - Face to face dims to API 6A
- **API 6D**
  - Flange dims to ANSI B16.5
  - Face to face dims to API 6D

### SOLID LUG TYPE

- Flange dims to ANSI B16.5 (MSS-SP44>24")
- Face to face dims to API 594
- \* Threaded lug type also available
- **JIS 2210 & KS B1511**
- **EXTENDED BODY**
  - Flange dims to ANSI B16.5

**PRESSURE CLASSES** • ASME 150 TO 1500 LB, PN 10 TO 40. • JIS & KS 5K TO 20K

### NOMINAL SIZE RANGE

ASME 150 lb.2" to 60"  
ASME 300 lb.2" to 40"  
ASME 600 lb.2" to 36"  
ASME 900 lb.2" to 36"  
ASME 1500 lb.2" to 24"

Larger diameter VALVE for the respective pressure classes can be designed and manufactured on request.

### RETAINERLESS DESIGN

Dual plate check VALVE are supplied retainerless as standard. Our patented design does not have any threaded plugs in the pressure boundary and totally eliminates the potential leakpath to atmosphere. This design meet fugitive emission control.

### SEAT

The seat is designed equal pressure at the plate with the state of stationary hour. The shape of rubber seat could not be changed even in many operation because of having its most hardness satisfaction. The metal to metal seated valve is tested to API 598.

### DISC (PLATE)

The two semicircle plate responsiveness of opening and closing is quick and it is strong against corrosion also has a strong durability.

### SPRING

The springs have been designed to endure stresses and also ensure operating without failure for much cycles.

### RUBBER LINED

Fully Rubber Lined Valve to avoid corrosion Inside are available.

## DUAL PLATE CHECK VALVE TYPES



Wafer Retainerless



Flanged Retainerless



Solid Lug Retainerless



Hub Ended

## STANDARD MATERIAL SPECIFICATIONS

NO.	PART NAME	MATERIAL		
1	BODY	A216 - WCB	A351 CF8M	A351 CF3M
2	DISC	A351 CF8M	A351 CF3M	A217 CA15
3	SEAT	SS 316	13 CR	STELLITE \$6
4	HINGE PIN	A276 316	A276 410	A276 304
5	STOP PIN	A276 316	A276 410	A276 304
6	SPRING	INCONEL X-750	SS 316	
7	GUIDE	A276 316	A276 410	A276 304
8	WASHER	A276 316	A276 304	
9	SET SCREW	A193 B7	A193 B8	A193 B8m
10	EYE BOLT	SS400 or SS304	SET SCREW	SS304

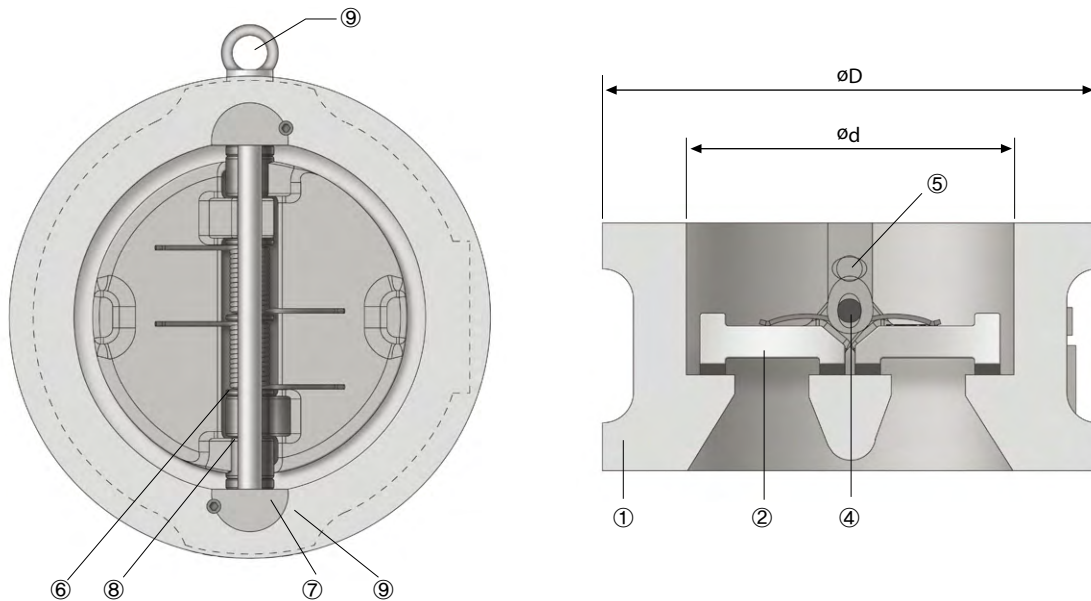

## DIMENSION AND WEIGHT

### CLASS 150

UNIT: mm

SIZE	2	3	4	6	8	10	12	14	16	18	20	24
øD	102	133	171	219	276	337	406	448	511	546	603	714
ød	60	87	113	166	207	260	300	339	387	438	487	580
L	60	73	73	98	127	146	181	184	191	203	219	222

### CLASS 300

UNIT: mm

SIZE	2	3	4	6	8	10	12	14	16	18	20	24
øD	108	146	178	248	305	359	419	483	537	594	651	772
ød	60	87	113	166	207	260	300	339	387	438	487	580
L	60	73	73	98	127	146	181	222	232	264	292	318

### CLASS 600

UNIT: mm

SIZE	2	3	4	6	8	10	12	14	16	18	20	24
øD	108	146	191	264	317	397	454	489	562	610	679	787
ød	60	87	113	166	207	260	300	339	387	438	487	580
L	60	73	79	137	165	213	229	273	305	362	368	438

### CLASS 900

UNIT: mm

SIZE	2	3	4	6	8	10	12	14	16	18	20	24
øD	140	165	203	286	356	432	495	518	571	635	695	835
ød	60	87	113	166	207	260	300	339	387	438	487	580
L	70	83	102	159	206	241	292	356	384	451	451	495

### CLASS 1500

UNIT: mm

SIZE	2	3	4	6	8	10	12	14	16	18	20	24
øD	140	171	206	279	349	432	518	575	638	702	752	899
ød	60	87	113	166	207	260	300	339	387	438	487	580
L	70	83	102	159	206	248	305	356	384	468	533	559



# STAINLESS STEEL VALVE

Stainless steel valve are utilized in the chemical, petrochemical, food, paper, and pharmaceutical processing industries all over the world.

Stainless steel valve are designed and manufactured in conformity with API, ANSI, BS and other standards recognized with quality meeting the stringent requirements for such industrial applications.

Stainless steel valve are specialized products through the processes of design, material selection, manufacturing, quality control, and experiences to final product.

## PRODUCTION RANGE

UNIT : NPS

TYPE	CLASS	150	300
GATE		1/2-24	1/2-24
GLOBE		1/2-12	1/2-12
SWING CHECK		1/2-24	1/2-24

## INVESTMENT CASTING

Investment casting shall be manufactured up to 1 1/2" for class 150 and 300.

## VALVE SHELL MATERIALS

Shell materials shall be in accordance with ASTM A351 Grade CF8M & CF8 and the others are optional.

ASTM DESIGNATION	MAXIMUM WORKING TEMPERATURE °F (°C)
A351 Gr. CF8	1500°F (816°C) *
A351 Gr. CF8M	1500°F (816°C) *
A351 Gr. CF3	800°F (427°C)
A351 Gr. CF3M	850°F (454°C)
A351 Gr. CF8C	1500°F (816°C) *
A351 Gr. CN7M	300°F (149°C)
A890 Gr 4A ( UNS J92205 )	600°F (316°C)
A890 Gr 6A ( UNS J93380 )	600°F (316°C)

\* At temperatures over 1000°F, use the material only when the carbon contents is 0.04% or higher.

## OPTIONAL BONNET FLANGE GASKET MATERIAL

Depending on service conditions, various materials are available optionally for flange gasket and stem packing.

### A. Gasket materials

1. Glass fiber sheet
2. Spiral wound material (Graphite or PTFE)
3. PTFE
4. Metal ring
5. Graphite

### B. Packing materials

1. PTFE
2. Graphite
3. Glass fiber sheet

## DESIGN FEATURES OF PK STAINLESS STEEL GATE VALVE WEDGES

PK adopts an H-shaped flexible wedge of which the size is 3" and larger for Class 150 and 2" and higher for Class 300/600. The H-shaped flexible wedges are featured with mechanical flexibility to be able to adjust to the shape of body seat for secure mutual contacts.

It has a particular importance when large gate valve is applied to extremely high pressure and temperature that temporary deformation may occur in valve all the time.

If the H-shape wedge is provided, operating torque would get smaller, seat wear less, and valve closing tighter.

UNIT : NPS

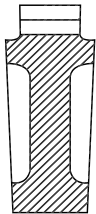
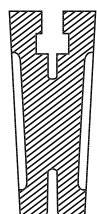
	ONE PIECE SOLID WEDGE	FLEXIBLE ONE PIECE WEDGE
CLASS		
150	2 1/2 & SMALLER	3 & LARGER
300	1 & SMALLER	1 1/2 & LARGER
600	-	2 & LARGER

## DESIGN FEATURES OF GLOBE VALVE DISC

Globe valve adopts plug type disc. The bottom guide type plug disc shall be applied following the range shown below.

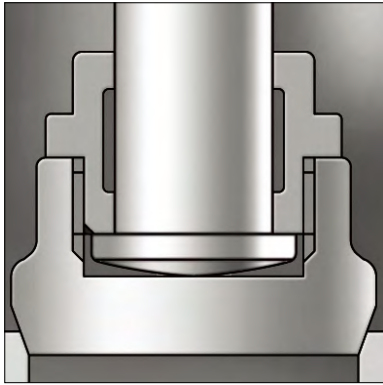

PLUG DISC

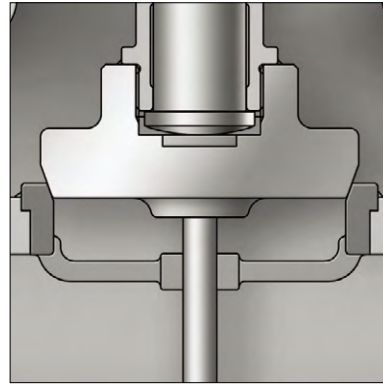

BOTTOM GUIDE  
TYPE  
PLUG DISC

UNIT: NPS

CLASS	SIZE
150	10 AND LARGER
300	8 AND LARGER

## DESIGN FEATURES OF GATE VALVE YOKE SLEEVE

It is manufactured by two different ways depending on the valve size.

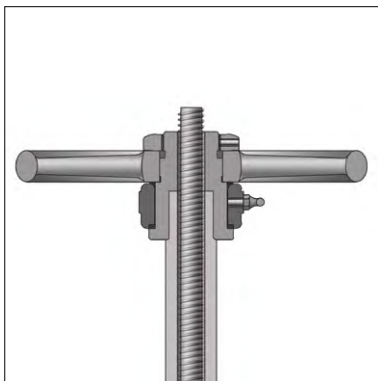

TYPE A

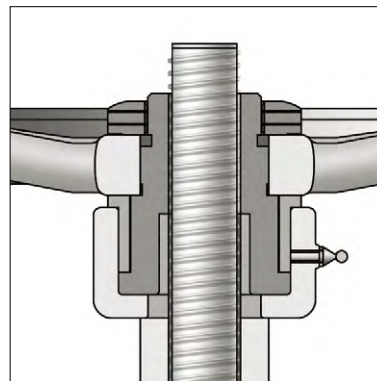

TYPE B

UNIT: NPS

TYPE A	TYPE B
5 AND SMALLER	6 AND LARGER

Yoke caps type B is made of CS 1020+Zn plating.

## DESIGN FEATURES OF GATE VALVE YOKE

On 10" and smaller valve, the yoke is integrated with bonnet.

On 12" and larger valve, the yoke is separated from bonnet.

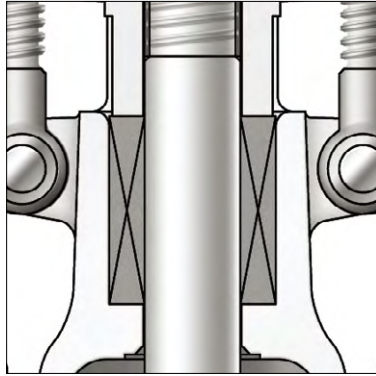

INTEGRAL YOKE

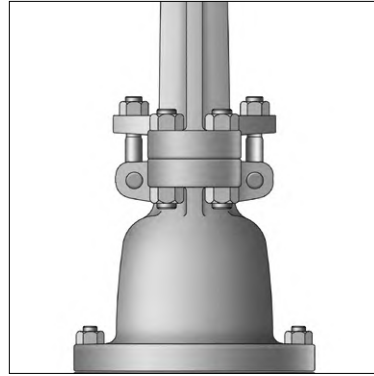

SEPARATE YOKE

## DESIGN FEATURES OF VALVE BONNET BOLTS

It is manufactured by two different ways depending on valve class and size.

UNIT : NPS

	CLASS	SIZE	BOLT
Type A	150	5 AND SMALLER	HEX. HEAD
	300	2 1/2 AND SMALLER	
Type B	150	6 AND LARGER	FULL THREAD. BOLT & NUT
	300	3 AND LARGER	

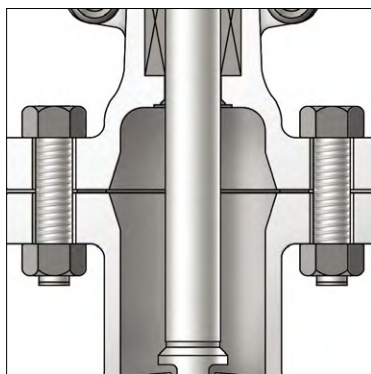

TYPE A  
HEX. HEADED BOLT

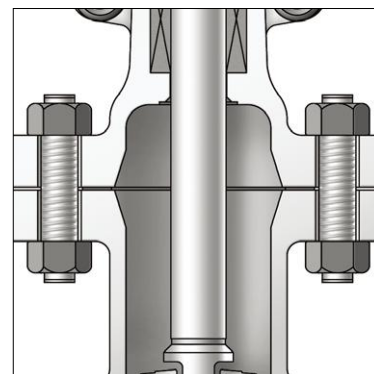

TYPE B  
STUD BOLT

## DESIGN FEATURES OF VALVE HAND WHEELS

Hand wheels are made in accordance with ASTM A 197 for external dimension 560mm and ASTM A216 WCB for over 560mm. A hammer blow type hand wheel of ASTM A216 WCB is provided for Class 150 (size 8) VALVE and Class 300 and over valve (size 6")

# GATE VALVE

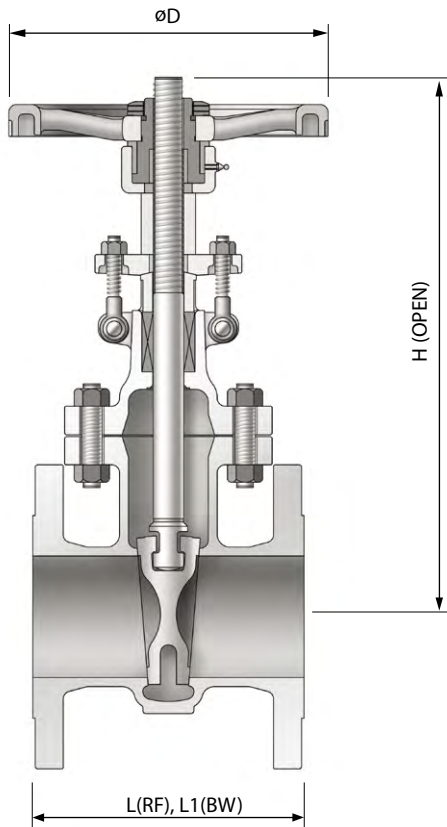

## STANDARD MATERIAL SPECIFICATIONS

NO.	PART NAME	MATERIAL	
1	BODY	A351 - CF8	A351 - CF8M
2	BONNET	A351 - CF8	A351 - CF8M
3	WEDGE	A351 - CF8	A351 - CF8M
4	STEM	A479 - 304	A479 - 316
5	HAND WHEEL	A197	A197
6	BODY SEAT	A351 - CF8	A351 - CF8M
7	BACK SEAT	A351 - CF8	A351 - CF8M
8	GASKET	SPIRAL WOUND / GRAPHITE+316+316	
9	PACKING	GRAPHITE+GRAPHITE WITH INCONEL WIRE	
10	GLAND FLANGE	A351 - CF8	A351 - CF8
11	HINGE BOLT	A193 - B8	A193 - B8
12	HINGE NUT	A194 - 8	A194 - 8
13	HINGE PIN	A479 - 304	A479 - 304
14	PACKING GLAND	A479 - 304	A479 - 316
15	BONNET BOLT	A193 - B8	A193 - B8
16	BONNET NUT	A194 - 8	A194 - 8
17	YOKE CAP	A576 - 1020+Zn	A576 - 1020+Zn
18	YOKE SLEEVE	A439 - D2C	A439 - D2C
19	HANDLE NUT	304 S.S	304 S.S
20	SET SCREW	STEEL+ Cr	STEEL+ Cr
21	NIPPLE	STEEL+ Cr	STEEL+ Cr

**END CONNECTION** - R.F FLANGED ENDS TO ASME B16.5  
 - B.W. ENDS TO ASME B16.25  
 - R.T.J FLANGED ENDS TO ASME B16.5  
 - CONSULT US FOR LARGER SIZE

## DIMENSION AND WEIGHT

### CLASS 150

UNIT:mm

SIZE	1/2	3/4	1	1 1/2	2	2 1/2	3	4	6	8	10	12
L	108.0	117.3	127.0	165.1	177.8	190.5	203.2	228.6	266.7	292.1	330.2	355.6
L1	108.0	117.3	127.0	165.1	215.9	241.3	282.4	304.8	403.4	419.1	457.2	501.7
D	120	120	120	140	160	160	200	250	315	355	355	400
H	208	208	226	285	333	384	424	531	730	938	1114	1317
WEIGHT(kg)	6	6	6	9	12	18	23	35	62	102	147	213

### CLASS 300

UNIT:mm

SIZE	1/2	3/4	1	1 1/2	2	2 1/2	3	4	6	8	10	12
L	139.7	152.4	165.1	190.5	215.9	241.3	282.4	304.8	403.4	419.1	457.2	501.7
L1	139.7	152.4	165.1	190.5	215.9	241.3	282.4	304.8	403.4	419.1	457.2	501.7
D	120	120	120	200	200	200	224	250	355	400	450	500
H	208	211	279	306	346	388	447	542	758	949	1152	1417
WEIGHT(kg)	8	8	8	16	18	29	39	54	112	202	253	390

# GLOBE VALVE

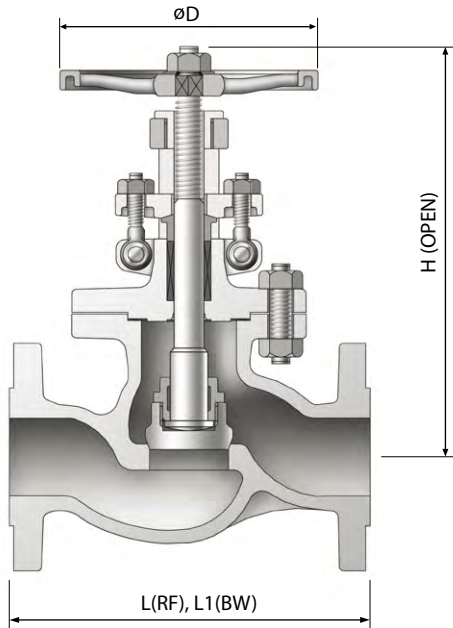

## STANDARD MATERIAL SPECIFICATIONS

NO.	PART NAME	MATERIAL	
1	BODY	A351 - CF8	A351 - CF8M
2	BONNET	A351 - CF8	A351 - CF8M
3	DISC	A351 - CF8	A351 - CF8M
4	STEM	A479 - 304	A479 - 316
5	HAND WHEEL	A197	A197
6	BODY SEAT	A351 - CF8	A351 - CF8M
7	BACK SEAT	A351 - CF8	A351 - CF8M
8	GASKET	SPIRAL WOUND / GRAPHITE+316+316	
9	PACKING	GRAPHITE+GRAPHITE WITH INCONEL WIRE	
10	GLAND FLANGE	A351 - CF8	A351 - CF8
11	HINGE BOLT	A193 - B8	A193 - B8
12	HINGE NUT	A194 - 8	A194 - 8
13	HINGE PIN	A479 - 304	A479 - 304
14	PACKING GLAND	A479 - 304	A479 - 316
15	BONNET BOLT	A193 - B8	A193 - B8
16	BONNET NUT	A194 - 8	A194 - 8
17	YOKE BUSH	A439 - D2C	A439 - D2C
18	LOCK NUT	A479 - 304	A479 - 316
19	HANDLE NUT	A194 - 8	A194 - 8
20	WASHER	304 S.S	304 S.S

**END CONNECTION**

- R.F FLANGED ENDS TO ASME B16.5
- B.W. ENDS TO ASME B16.25
- R.T.J FLANGED ENDS TO ASME B16.5
- CONSULT US FOR LARGER SIZE

## DIMENSION AND WEIGHT

### CLASS 150

SIZE	UNIT : mm											
	1/2	3/4	1	1 1/2	2	2 1/2	3	4	6	8	10	12
L	108.0	117.3	127.0	165.1	203.2	215.9	241.3	292.1	406.4	495.3	622.3	698.5
L1	108.0	117.3	127.0	165.1	203.2	215.9	241.3	292.1	406.4	495.3	622.3	698.5
D	100	100	140	160	160	200	224	280	355	355	400	400
H	174	174	224	259	266	281	342	377	429	558	740	803
WEIGHT(kg)	4	4	4	10	13	21	27	42	76	149	241	395

### CLASS 300

SIZE	UNIT : mm											
	1/2	3/4	1	1 1/2	2	2 1/2	3	4	6	8	10	12
L	152.4	177.8	203.2	228.6	266.7	292.1	317.5	355.6	444.5	558.8	622.3	711.2
L1	152.4	177.8	203.2	228.6	266.7	292.1	317.5	355.6	444.5	558.8	622.3	711.2
D	100	100	140	160	160	200	224	280	355	400	450	500
H	185	194	224	267	329	354	383	443	567	625	881	989
WEIGHT(kg)	9	9	9	15	17	33	34	46	125	218	367	521

# SWING CHECK VALVE

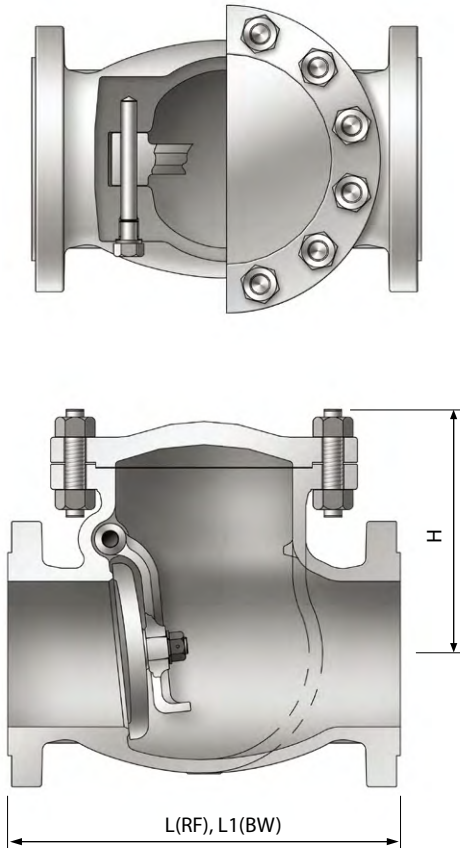

## STANDARD MATERIAL SPECIFICATIONS

NO.	PART NAME	MATERIAL	
1	BODY	A351 - CF8	A351 - CF8M
2	BONNET	A351 - CF8	A351 - CF8M
3	DISC	A351 - CF8	A351 - CF8M
4	ARM	A351 - CF8	A351 - CF8M
5	ROD PIN	A479 - 304	A479 - 304
6	BODY SEAT RING	A351 - CF8	A351 - CF8M
7	PLUG BOLT	A479 - 304	A479 - 304
8	GASKET	SPIRAL WOUND / GRAPHITE+316+316	
9	PLUG GASKET	304 S.S	304 S.S
10	BONNET BOLT	A193 - B8	A193 - B8
11	BONNET NUT	A194 - 8	A194 - 8
12	DISC NUT	A194 - 8	A194 - 8M
13	PIN	304 S.S	304 S.S
14	WASHER	A240 - 304	A240 - 304

- END CONNECTION**
- R.F FLANGED ENDS TO ASME B16.5
  - B.W. ENDS TO ASME B16.25
  - R.T.J FLANGED ENDS TO ASME B16.5
  - CONSULT US FOR LARGER SIZE

## DIMENSION AND WEIGHT

### CLASS 150

UNIT : mm

SIZE	1/2	3/4	1	1 1/2	2	2 1/2	3	4	6	8	10	12
L	108.0	117.3	127.0	165.1	203.2	215.9	241.3	292.1	355.6	495.3	622.3	698.5
L1	108.0	117.3	127.0	165.1	203.2	215.9	241.3	292.1	355.6	495.3	622.3	698.5
H	85	89	102	120	138	155	160	201	248	293	330	354
WEIGHT(kg)	5	5	5	11	13	18	22	36	62	119	155	235

### CLASS 300

UNIT : mm

SIZE	1/2	3/4	1	1 1/2	2	2 1/2	3	4	6	8	10	12
L	152.4	177.8	215.9	241.3	266.7	292.1	317.5	355.6	444.5	533.4	622.3	711.2
L1	152.4	177.8	215.9	241.3	266.7	292.1	317.5	355.6	444.5	533.4	622.3	711.2
H	93	96	112	126	152	164	176	186	262	312	355	393
WEIGHT(kg)	10	10	10	14	19	25	33	53	109	199	231	308



**Head Office & Factory**

51567, 80, Gongdan-ro, Seongsan-gu, Changwon-si,  
Gyeongsangnam-do, Korea  
TEL 82-55-268-3719 FAX 82-55-286-0281

**R&BD Center**

TEL 82-55-268-3810~9 FAX 82-55-286-3804  
E-mail : mst@pkvalve.co.kr

**Service Center**

TEL 82-55-286-0638 FAX 82-55-286-0639