

NDV

Catalog No.BE301-03



BALL VALVES

NIPPON DAIYA VALVE CO., LTD.

■ Fire-Safe Ball Valve (F100NB)

● Features

(1) Secondary Seat

If the PTFE seat is destroyed by fire or the like, the ball adheres directly to the metal seat provided on the seat, preventing excessive leakage from the valve seat. The flow is not directional and there are metal seats on all sides.

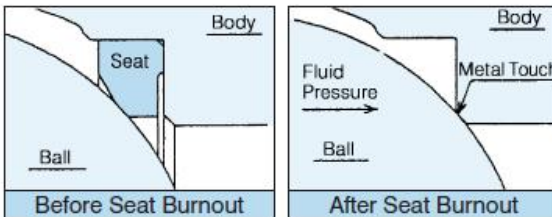

Figure 1

(2) Metal-to-Metal Body Seal

The seals for the body and flange joints have a double-layer sealing mechanism made up of a gasket and a metal-to-metal contact. This prevents excessive leakage to the outside of the valve from the body joints in the event that the gasket is destroyed by fire.

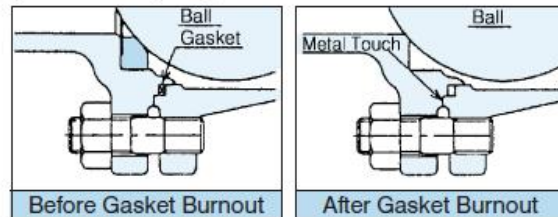

Figure 2

(3) Stem Guard Mechanism

The flange provided on the stem prevents the stem from popping out due to fluid pressure. Also, in the event that the gland packing is destroyed by fire, the stem flange adheres to the body, preventing excessive fluid leakage to the outside of the valve.

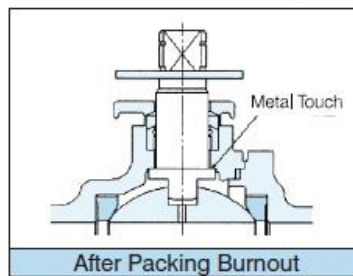
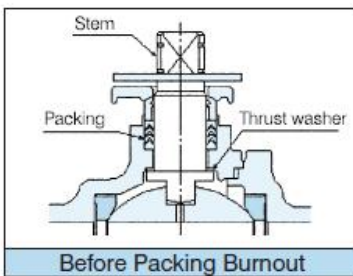

Figure 3

(4) Antistatic Mechanism

The antistatic mechanism can be provided to prevent the accumulation of static electricity (produced by friction between the ball and seat) inside the valve.

The antistatic mechanism consists of a wire spring inserted into the groove inside the packing retainer ring.

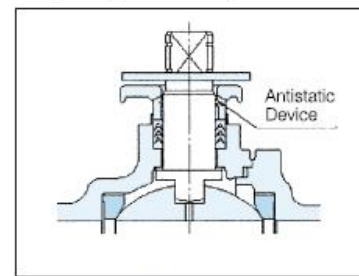

Figure 4

● Standard Specification

- Nominal Size: Full Port Floating Ball (F100NB), DN15 to 200
- Face-to-Face Dimension: ISO5752 Compliant
- Connection: Flange
 - J10K, J20K, Class (ANSI, JPI) 150, 300
- Parts Materials: Body — Carbon Cast Steel: SCPH2 (WCB)
 Spheroidal Graphite Cast Iron: FCD400
 Stainless Cast Steel: SCS13A (CF8), SCS14A (CF8M), SCS16A (CF3M)
 Ball — SUS304 (SCS13A), SUS316 (SCS14A), SUS316L (SCS16A)
 Seat — New-PTFE and others (A page 8 is referred to)
- Pressure-Temperature Range: Please see the seat rating table.
- Operation Style: Lever Operated, Gear Operated
 - Pneumatic (Double/Reverse/Direct Acting)
 - Electric
- Coating (Body): Only Anti-Corrosive Coating (Except for Stainless Steel)

■ Fire-Safe Ball Valve (F100NB)

● Standard Configuration

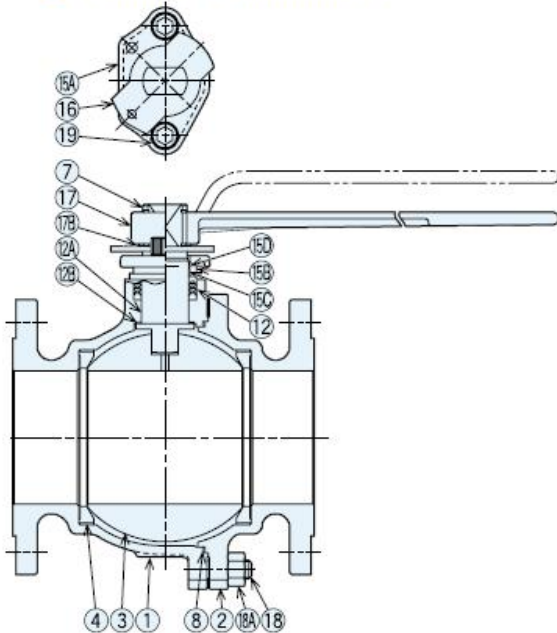

Parts	Materials				
	Ductile Cast Iron	Stainless Cast Steel			Cast Steel
1	FCD400	SCS13A	SCS14A	SCS16A	SCPH2
2	FCD400	SCS13A	SCS14A	SCS16A	SCPH2
3	SUS304 or SCS13A	SUS304 or SCS13A	SUS316 or SCS14A	SUS316L or SCS16A	SUS304 or SCS13A
4	NTF, NCF, and others				
7	SUS304	SUS304	SUS316	SUS316L	SUS304
8	New-PTFE				
12	New-PTFE				
12A	New-PTFE				
12B	New-PTFE				
15A	SCS13A				
15B	SUS304				
15C	New-PTFE				
15D	SUS304				
16	SUS304				
17	SCPH2 (15A/100A), SCPH2 + STK490 (125A/200A)				
17B	SUS304				
18	SNB7	SUS304	SUS304	SUS304	SNB7
18A	S45C	SUS303	SUS303	SUS303	S45C
19	SUS304				
20	SUS304 (125A/200A, for fixing handle)				

● Production Range (Nominal Size: 15A/200A)

Materials	Class			
	J10K	CL150	J20K	CL300
FCD400	○	○	—	—
SCS13A	○	○	○	○
SCS14A	○	—	—	—
SCS16A	○	○	○	○
SCPH2	○*	—	—	—

*: Only Nominal Size 125A/200A



● Boundary Dimension

○ F100NB (Full Port)

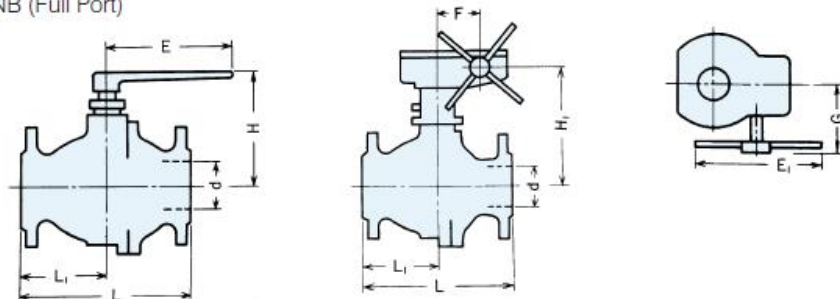

unit: mm

DN	d	Stainless Cast Steel, Cast Steel, Ductile Cast Iron				Lever Operated		Gear Operated								approx. Mass (kg)					
		L		L1		H	E		H1		G		F		E1		Lever Operated		Gear Operated		
		10K CL150	20K CL300	10K CL150	20K CL300		10K CL150	20K CL300	10K CL150	20K CL300	10K CL150	20K CL300	10K CL150	20K CL300	10K CL150	20K CL300	10K CL150	20K CL300	10K CL150	20K CL300	
1 5	13	108	140	45	63	80												1.9	2.3		
2 0	19	117	152	50	70	85	130	130										2.5	3.0		
2 5	25	127	165	51	71	100	160	160										4.0	4.7		
4 0	38	165	190	70.5	76.5	115												6.5	7.3		
5 0	51	178	216	80.5	86	120	230	230										8.5	10.1		
6 5	64	190	241	87	103	135												13.5	17.0		
8 0	76	203	283	97	124	145	350	350										16.5	23.0		
1 0 0	102	229	305	116	135	180	450	450	280	285	165	190	62.5	77	240	300	27	38.5	41	57.5	
1 2 5	127	356	381	148	158	260			342	342		190	230	77	90.5	300	46	59	73	92	
1 5 0	152	394	403	173	178	280	650	800								460	61	75	88	108	
2 0 0	203	457	502	207	235	350	800	1100	425	446	230	260	90.5	121	460		98	123	135	174	

● Pressure-Temperature Range

○ Valves: F100NB, E100JNC, E300NB-L2, EK100N (Trunnion)

Code	Seat Materials	applied to	Type
NTF	New-PTFE	①	for Floating Ball
NCF	Reinforced PTFE (with Carbon Fiber)		
CFMR	CF + Outside & Inside Metal Ring	②	for Trunnion Ball
CFRS	CF + Additional Retainer + O-Ring (NBR)	③	
	CF + Additional Retainer + O-Ring (FKM)	④	

