



Cat.no.:E-PS



Cat.no.:E-GGC



Cat.no.:E-CSS



Cat.no.:E-FSV



Cat.no.:TOBV



Cat.no.:E-CBV



Cat.no.:E-CV



Cat.no.:E-CBV



Cat.no.:E-FWBV



Cat.no.:E-FBV

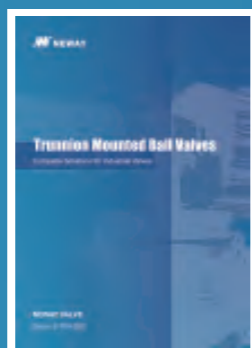

Cat.no.:E-TMBV



Cat.no.:E-MSBV

# Gate, Globe & Check Valves

Complete Solutions for Industrial Valves

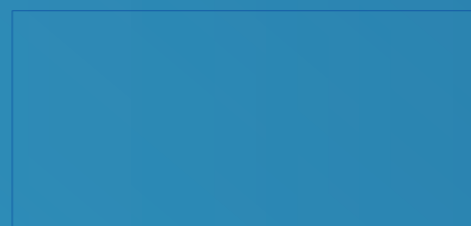

# Table of Contents

## Introduction

- 1 Quality Commitment
- 2 Product Range
- 3 Technical Innovation
- 4 Introduction of Foundries
- 5 Advanced Manufacturing & Quality Control
- 6 ~ 7 Typical Product View
- 8 How to Order

## Gate Valve

- 9 Design Feature
- 10 Material List
- 11 ~ 13 Dimension & Weight

## Globe Valve

- 14 Design Feature
- 15 Material List
- 16 ~ 18 Dimension & Weight

## Check Valve

- 19 Design Feature
- 20 Material List
- 21 ~ 23 Dimension & Weight

## Pressure Seal Gate Valve

- 24 Design Feature
- 25 Material List
- 26 ~ 27 Dimension & Weight

## Pressure Seal Globe Valve

- 28 Design Feature
- 29 Material List
- 30 ~ 31 Dimension & Weight

## Pressure Seal Check Valve

- 32 Design Feature
- 33 Material List
- 34 ~ 35 Dimension & Weight

## Gear Operator

## Low Fugitive Emission Control

- 38 ~ 40 Special Design Feature



## Complete Solutions for Industrial Valves

As a global leader of valve manufacturing, Neway (SSE:603699) is dedicated to the production, research, and development of industrial valves. Neway is committed to providing complete valve solutions to all industries through advanced engineering and innovation.

Neway's product line includes Ball, Butterfly, Gate, Globe, Check, Nuclear, Control, Subsea, Safety valves. Our high quality standards and innovative ability are recognized by many global end users and EPCs. Neway valves are utilized in a wide variety of industries and working conditions such as Refining, Chemical, Coal Chemical, Offshore(including subsea), Air Separation, LNG, Nuclear Power, Power Generation, and Pipeline Transmission applications.

## Facilities & Service

Neway has developed a sophisticated multi-plant management system operating one valve assembly plant, one API6A valve plant, three foundries, and one R&D center. Our largest assembly plant was expanded in 2013, and it now covers 35,000 square meters.

Advanced software (ANSYS, FE-Safe, CF-Design, Siemens PLM and NX) is applied here at Neway for the Research & Development of products. We use SAP&MES to control the traceability and status of all products during the manufacturing process. In order to ensure the safety, eco-friendliness, and reliability of our products, we use the most advanced fire-safe, cryogenic, high pressure, and fugitive emission test equipment.

As part of Neway's global strategy, to provide better service to our customers, we have established our overseas subsidiaries in USA, Netherlands, Italy, Singapore, Dubai, Vietnam and Nigeria along with over 80 agents and distributors worldwide.

## Quality Assurance

Neway is dedicated to the pursuit of "Zero Defect". We maintain a quality management system that encompasses our entire operation from order entry, to final inspection. Through Neway's continuous efforts, our products have successfully achieved industrial certificates including ISO 9001, API 6A, API 6D, CE/PED, ASME N & NPT, TA-LUFT, ABS, CU-TR, and Fire-Safe approvals.



NORSOK



API Q1



CE/PED



Fire Safe Test Certificate



TA-LUFT



ABS



API 6D



AD2000

Neway recognizes the importance of valve quality for the safety and protection of personnel health and property. It is our quality commitment to focus our resources to provide our customers with first class products at a competitive price, designed, manufactured, inspected and tested in accordance with our customers specifications and complying with all international standards.

Current industrial standards do not always take into consideration the likelihood and consequences of possible deterioration in service, related to specific service fluids or the external environments in which they operate. Therefore we request that our customers communicate with our engineering department. Our valve optimization program continuously strives to provide valves that withstand deterioration in service, and ensure safety over the valves expected lifetime.

Bolted Bonnet Valve

Type Size	Gate Valve							Globe Valve					Check Valve									
	150	300	600	900	1500	2500	4500	150	300	600	900	1500	2500	4500	150	300	600	900	1500	2500	4500	
2"	●	●	●	●	●	●	●	●	●	●	●	●	●	●	●	●	●	●	●	●	●	●
2.5"	●	●	●	●	●	●	●	●	●	●	●	●	●	●	●	●	●	●	●	●	●	●
3"	●	●	●	●	●	●	●	●	●	●	●	●	●	●	●	●	●	●	●	●	●	●
4"	●	●	●	●	●	●	●	●	●	●	●	●	●	●	●	●	●	●	●	●	●	●
5"	●	●	●	●	●	●	●	●	●	●	●	●	●	●	●	●	●	●	●	●	●	●
6"	●	●	●	●	●	●	●	●	●	●	●	●	●	●	●	●	●	●	●	●	●	●
8"	●	●	●	●	●	●	●	●	●	●	●	●	●	●	●	●	●	●	●	●	●	●
10"	●	●	●	●	●	●	●	●	●	●	●	●	●	●	●	●	●	●	●	●	●	●
12"	●	●	●	●	●	●	●	●	●	●	●	●	●	●	●	●	●	●	●	●	●	●
14"	●	●	●	●	●	●	●	●	●	●	●	●	●	●	●	●	●	●	●	●	●	●
16"	●	●	●	●	●	●	●	●	●	●	●	●	●	●	●	●	●	●	●	●	●	●
18"	●	●	●	●	●	●	●	●	●	●	●	●	●	●	●	●	●	●	●	●	●	●
20"	●	●	●	●	●	●	●	●	●	●	●	●	●	●	●	●	●	●	●	●	●	●
24"	●	●	●	●	●	●	●	●	●	●	●	●	●	●	●	●	●	●	●	●	●	●
26"	●	●	●	●	●	●	●	●	●	●	●	●	●	●	●	●	●	●	●	●	●	●
28"	●	●	●	●	●	●	●	●	●	●	●	●	●	●	●	●	●	●	●	●	●	●
30"	●	●	●	●	●	●	●	●	●	●	●	●	●	●	●	●	●	●	●	●	●	●
32"	●	●	●	●	●	●	●	●	●	●	●	●	●	●	●	●	●	●	●	●	●	●
36"	●	●	●	●	●	●	●	●	●	●	●	●	●	●	●	●	●	●	●	●	●	●
40"	●	●	●	●	●	●	●	●	●	●	●	●	●	●	●	●	●	●	●	●	●	●
42"	●	●	●	●	●	●	●	●	●	●	●	●	●	●	●	●	●	●	●	●	●	●
48"	●	●	●	●	●	●	●	●	●	●	●	●	●	●	●	●	●	●	●	●	●	●
52"	●	●	●	●	●	●	●	●	●	●	●	●	●	●	●	●	●	●	●	●	●	●
54"	●	●	●	●	●	●	●	●	●	●	●	●	●	●	●	●	●	●	●	●	●	●
56"	●	●	●	●	●	●	●	●	●	●	●	●	●	●	●	●	●	●	●	●	●	●
60"	●	●	●	●	●	●	●	●	●	●	●	●	●	●	●	●	●	●	●	●	●	●
64"	●	●	●	●	●	●	●	●	●	●	●	●	●	●	●	●	●	●	●	●	●	●
66"	●	●	●	●	●	●	●	●	●	●	●	●	●	●	●	●	●	●	●	●	●	●
68"	●	●	●	●	●	●	●	●	●	●	●	●	●	●	●	●	●	●	●	●	●	●
70"	●	●	●	●	●	●	●	●	●	●	●	●	●	●	●	●	●	●	●	●	●	●
72"	●	●	●	●	●	●	●	●	●	●	●	●	●	●	●	●	●	●	●	●	●	●
88"	●	●	●	●	●	●	●	●	●	●	●	●	●	●	●	●	●	●	●	●	●	●

Pressure Seal Valve

Type Size	Gate Valve					Globe Valve					Check Valve				
	600	900	1500	2500	4500	600	900	1500	2500	4500	600	900	1500	2500	4500
2"	●	●	●	●	●	●	●	●	●	●	●	●	●	●	●
2.5"	●	●	●	●	●	●	●	●	●	●	●	●	●	●	●
3"	●	●	●	●	●	●	●	●	●	●	●	●	●	●	●
4"	●	●	●	●	●	●	●	●	●	●	●	●	●	●	●
5"	●	●	●	●	●	●	●	●	●	●	●	●	●	●	●
6"	●	●	●	●	●	●	●	●	●	●	●	●	●	●	●
8"	●	●	●	●	●	●	●	●	●	●	●	●	●	●	●
10"	●	●	●	●	●	●	●	●	●	●	●	●	●	●	●
12"	●	●	●	●	●	●	●	●	●	●	●	●	●	●	●
14"	●	●	●	●	●	●	●	●	●	●	●	●	●	●	●
16"	●	●	●	●	●	●	●	●	●	●	●	●	●	●	●
18"	●	●	●	●	●	●	●	●	●	●	●	●	●	●	●
20"	●	●	●	●	●	●	●	●	●	●	●	●	●	●	●
24"	●	●	●	●	●	●	●	●	●	●	●	●	●	●	●
26"	●	●	●	●	●	●	●	●	●	●	●	●	●	●	●
28"	●	●	●	●	●	●	●	●	●	●	●	●	●	●	●
30"	●	●	●	●	●	●	●	●	●	●	●	●	●	●	●
32"	●	●	●	●	●	●	●	●	●	●	●	●	●	●	●
36"	●	●	●	●	●	●	●	●	●	●	●	●	●	●	●
40"	●	●	●	●	●	●	●	●	●	●	●	●	●	●	●
42"	●	●	●	●	●	●	●	●	●	●	●	●	●	●	●
48"	●	●	●	●	●	●	●	●	●	●	●	●	●	●	●
52"	●	●	●	●	●	●	●	●	●	●	●	●	●	●	●
54"	●	●	●	●	●	●	●	●	●	●	●	●	●	●	●
56"	●	●	●	●	●	●	●	●	●	●	●	●	●	●	●
60"	●	●	●	●	●	●	●	●	●	●	●	●	●	●	●

- Note:
1. Face to face and end to end dimension conform to BS EN 558, BS EN 12627, ASME B16.10 or ISO 5752.
  2. Flange type and size in accordance with ASME B16.5& ASME B16.47.
  3. BW end dimension conform to ASME B16.25
  4. Inspection and test in accordance with API 598 or BS EN 12266.
  5. Valves larger than 64" are manufactured per Neway standards.

Technical Innovation

With cutting-edge computer technology utilized, NEWAY Technical Center focuses on providing outstanding quality products and developing new lines. There is a highly educated and well-trained engineering team, supported by a comprehensive internal computer network which links the entire operations of design, manufacturing and administration.

NEWAY design philosophy is to develop a safe and cost-efficient valve. We introduced the latest Ansys. Fe-safe CF-design and NX software for all our new product design research which include the advanced finite element analysis, fluid and fatigue analysis to virtually verify the new design prior to production, which has resulted in dramatically shortening development duration and assure a safe and cost-efficient final product.

NEWAY technical personnel are always ready to offer on line or on site technical training and support for all of its distributors, agents and end users.



Flow Coefficient Test



Low Fugitive Emission Test



High Temperature Test



Fire Safe Test



Low Temperature Test



Valve casting quality is of prime importance for product life, personnel and environmental safety, particularly in high temperature and high pressure service as valve serves as one of pressure-containing equipment in process-controlled pipeline. Thus, castings are always certified firstly by the customers requiring strictly before a valve manufacturer is pre-qualified and approved as a qualified supplier.

Compared with most of other competitors, we own three foundries: two of them work on producing large-sized sand castings by Sodium silicate sand casting, and two of them are for production of small-sized investment castings by lost-wax casting. Besides, each is equipped with all kinds of quality inspection facilities, such as spectrum instrument, non-destructive test machinery, and mechanical property test device. Against such backdrop, Neway can monitor the whole process of manufacture to ensure product quality, delivery and competitive price and enable Neway to remain a creditable supplier for every customer.



Automatic Molding Line



Exported Sand Mixer



Automatic Forklift for Heat Treating

Supply Range & Capacity:

Plant Name	Dafeng Foundry	Suzhou Foundry
Process Technology	Lost wax investment casting	Sodium silicate sand casting
Size Range (in)	1/2" ~10"	2" ~76"
Pressure Rating	Class 150~600	Class 150~2500
Weight (Kg)	1~180	100~11000
Material	WCA、WCB、WCC、LCB、LCC、LCA、LC3、WC5、WC6、WC9、C5、C12、C12A、CA15、CF3、CF3M、CF8、CF8M、CN7M、CG3M、CG8M、CF8C、CF10、CF10M、4A、5A、6A、1B(CD4MCuN)、4C、CN3MCu、1.0619、1.6220、1.5419、1.7357、1.7379、1.7221、1.7363、1.4408、1.4308 etc.	
Monthly Capacity (Ton)	1500	1800
Quality Certificate	ISO9001,CE/PED,AD W0,NORSOK, ISO14001,ISO45001,LR/DNV.GL/CCS/B-V/ABS marine	ISO9001,CE/PED,NORSOK,ISO14001, ISO45001,CNAS,UKCA/PEDM,AD W0,LR/D-NV.GL/CCS/BV/ABS marine

The latest computer technology has been extensively applied in NEWAY manufacturing, which includes a large number of numeric control machines (machining center, CNC horizontal and vertical lathe and CNC drilling machine) and ERP management system. Additionally, the data through all factories have been connected and shared. These facilitate resource integration, boost productivity, evidently enhancing machining quality and tightening process control.



NEWAY developed comprehensive and advanced inspection and test facilities to control the quality from rough castings or forgings to final products, which enable us to perform radiographic test, liquid penetrant test, magnetic-particle test, spectrum analysis, Material Positive Identification (MPI), impact test, tensile test, hardness test, fire safe test, cryogenic test, vacuum test, low fugitive emission test, high pressure gas test, ultrasonic testing and hydrostatic test.



1



2



3



- 1 88" Class 150 Gate Valve
- 2 32" Class 150 Electric Gate Valve
- 3 24" Class 300 Pneumatic Gate Valve
- 4 30" Class 600 Globe Valve
- 5 52" Class 150 Cryogenic Gate Valve
- 6 42" Class 150 Check Valve
- 7 24" Class 2500 F91 Gate Valve



4



5



6



7

Example:



Neway figure numbers are designed to cover essential features. When ordering, please show the figure numbers and a detailed description to avoid misunderstanding of your requirements.

Following descriptions provide a basic guideline in valve specification:

① Valve Size

② Valve Type      ③ ANSI Class

Valve Type	Gate Valve	Globe Valve	Swing Check Valve	Code	1	3	6	9	15	25
Symbol	G&GPS	GL&GLP	SN&SPS	Class(LB)	150	300	600	900	1500	2500

④ End Connection

Symbol	End	Symbol	End
R	Raised face flanged end	S	Socket welding end
J	RTJ flanged end	N	Screwed end
B	Butt-welding end	F	Flat face flanged end
W	Wafer		

⑤ Description

Symbol	Description
G	Handwheel Operator
M	Electric Actuator
P	Pneumatic actuator

⑥ Shell Material

Material	C00	L20	L21	H01	H02	H03	S00	S01	S02	S03	N04
ASTM Ref	A216 Gr.WCB	A352 Gr.LCB	A352 Gr.LCC	A217 Gr.WC6	A217 Gr.WC9	A217 Gr.C5	A351 Gr.CF8	A351 Gr.CF8M	A351 Gr.CF3	A351 Gr.CF3M	A351 Gr.CN7M

⑦ Trim Material

API600 Trim Number	Symbol	Disc Surface	Seat Surface	Stem Material
1	1	13Cr	13Cr	ASTM A182 Grade F6a
2	2	18Cr -8Ni	18Cr -8Ni	ASTM A182 Grade F304
5	5	Stellite	Stellite	ASTM A182 Grade F6a
8	8	13Cr	Stellite	ASTM A182 Grade F6a
9	9	Monel	Monel	Ni Cu Alloy Monel
10	10	18Cr -8Ni	18Cr -8Ni	ASTM A182 Grade F316
12	12	18Cr -8Ni	Stellite	ASTM A182 Grade F316
13	13	Alloy 20 19Cr -29Ni	Alloy 20 19Cr -29Ni	Alloy 20
	16	Stellite	Stellite	ASTM A182 Grade F316
	20	Bronze	Bronze	Bronze

Note: 1.The denotation of trim No. 1 to 13 are the same as that of Table 8 in API 600.  
2.Trim number 1 may be replaced by trim number 8 without notice.

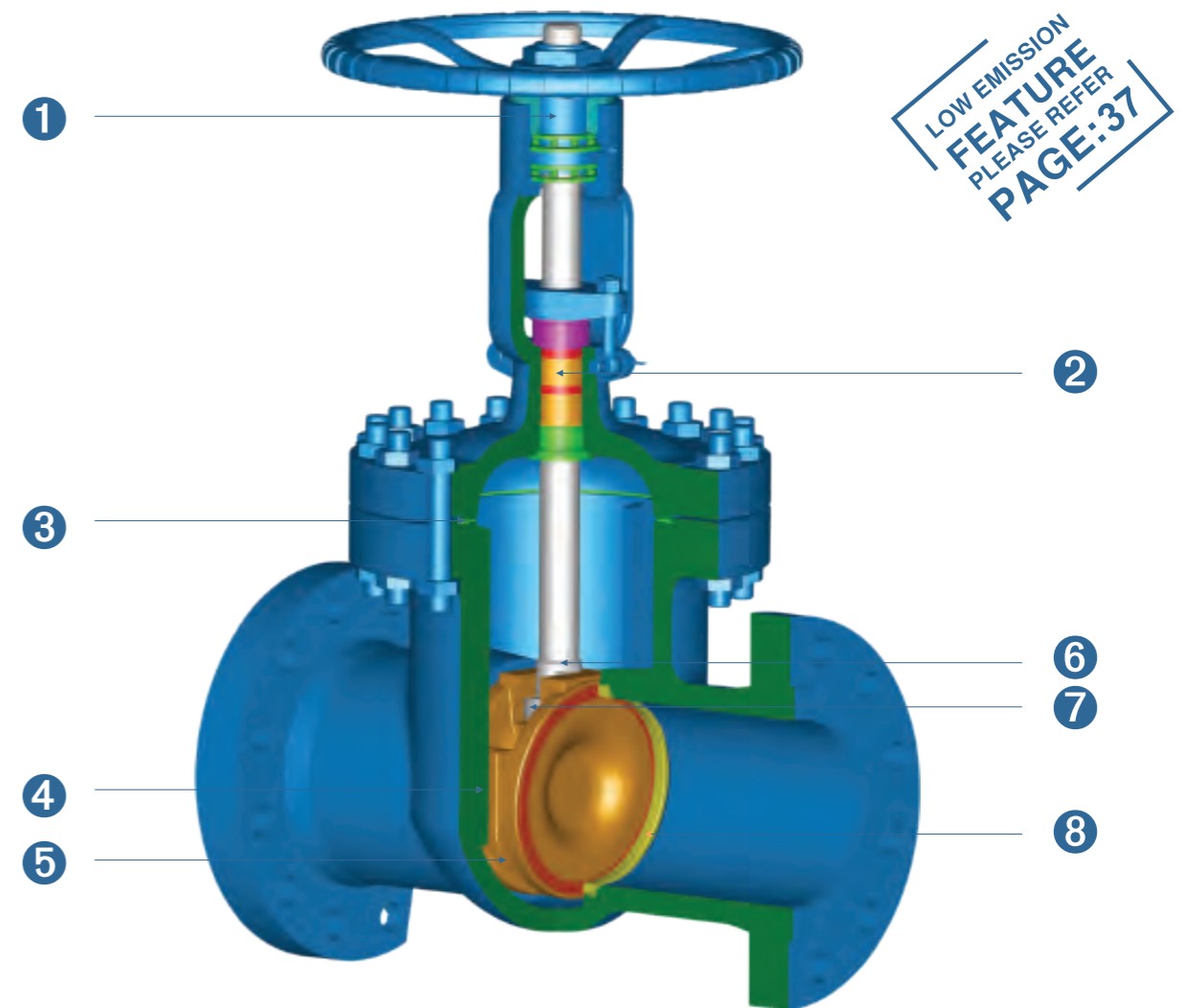

- ① Long thread stem nut prolongs thread life and permits the removal of hand wheel in the fully open position.
- ② Spacer ring in conjunction with packing is used in gate valves of 300 class and above while 150-class valve is only fitted with packing; packing with lantern ring is available upon customer request.
- ③ Corrugated metal with graphite filler gasket used for 150 Class gate valve, spiral wound gasket for Class 300 & 600 valves and metal ring gasket for gate valves of 900 or areater Class(600 Class is obtainable if customer requires)
- ④ Integral guide inside body keeps wedge self-centered during valve opening and closing.
- ⑤ Flexible wedge is able to compensate for seat surface distortion and body deformation caused by piping stress.
- ⑥ Blowout retention design: the tapered backseat face firmly contacts backseat of bonnet.
- ⑦ The strength of bonnet-wedge connection exceeds that of bonnet thread root.
- ⑧ Renewable seal welded seats with stellite 6 are standard design while screwed-in seats are optional.

Part	Standard	Low Temperature Service	High Temperature Service	Stainless Steel	Sour Service
BODY	ASTM A216-WCB	ASTM A352-LCC	ASTM A217-WC9	ASTM A351-CF8M	ASTM A216-WCB
BONNET	ASTM A216-WCB	ASTM A352-LCC	ASTM A217-WC9	ASTM A351-CF8M	ASTM A216-WCB
WEDGE	ASTM A216-WCB/CR13 OVERLAY or ASTM A217-CA15	ASTM A352-LCC/316 OVERLAY	ASTM A217-WC9/STL OVERLAY	ASTM A351-CF8M	ASTM A216-WCB/CR13 OVERLAY-NC or ASTM A217-CA15
STEM NUT	ASTM A439 D-2 or BRONZE	ASTM A439 D-2 or BRONZE	ASTM A439 D-2 or BRONZE	ASTM A439 D-2 or BRONZE	ASTM A439 D-2 or BRONZE
GLAND FLANGE	ASTM A105N	ASTM A350 LF2	ASTM A105N	ASTM A182-F316	ASTM A105N
HANDWHEEL	DUCTILEIRON	DUCTILEIRON	DUCTILEIRON	DUCTILEIRON	DUCTILEIRON
SEAT RING	ASTM A105/STL. OVERLAY	ASTM A182-F316/STL. OVERLAY	ASTM A182-F22/STL. OVERLAY	ASTM A182-F316/STL. OVERLAY	ASTM A105/STL. OVERLAY
STEM	ASTM A182-F6a	ASTM A182-F316	ASTM A182-F6a	ASTM A182-F316	ASTM A182-F6a-NC
BACK SEAT	ASTM A276-420	ASTM A276-316	ASTM A276-420	ASTM A276-316	ASTM A276-420-NC
GLAND	ASTM A276-420	STAINLESS STEEL	ASTM A276-420	ASTM A276-316	ASTM A276-420-NC
GASKET	REINFORCED GRAPHITE GASKET / SPIRAL WOUND GASKET	REINFORCED GRAPHITE GASKET / SPIRAL WOUND GASKET	REINFORCED GRAPHITE GASKET / SPIRAL WOUND GASKET	REINFORCED GRAPHITE GASKET / SPIRAL WOUND GASKET	REINFORCED GRAPHITE GASKET / SPIRAL WOUND GASKET
PACKING	GRAPHITE+SS	GRAPHITE+SS	GRAPHITE+SS	GRAPHITE+SS	GRAPHITE+SS
RETAINING NUT	CARBON STEEL	CARBON STEEL	CARBON STEEL	STAINLESS STEEL	CARBON STEEL
HANDWHEEL NUT	CARBON STEEL	CARBON STEEL	CARBON STEEL	STAINLESS STEEL	CARBON STEEL
BONNET STUD	ASTM A193-B7	ASTM A320-L7M	ASTM A193-B16	ASTM A193-B8 Class2	ASTM A193-B7M
BONNET NUT	ASTM A194-2H	ASTM A194-7M	ASTM A194-7	ASTM A194-8	ASTM A194-2HM
EYE BOLT	ASTM A193-B7	ASTM A320-L7M	ASTM A193-B16	ASTM A193-B8	ASTM A193-B7M
GLAND NUT	ASTM A194-2H	ASTM A194-7M	ASTM A194-7	ASTM A194-8	ASTM A194-2HM
EYE BOLT PIN	CARBON STEEL	STAINLESS STEEL	STAINLESS STEEL	STAINLESS STEEL	CARBON STEEL
NAME PLATE	STAINLESS STEEL	STAINLESS STEEL	STAINLESS STEEL	STAINLESS STEEL	STAINLESS STEEL

**Class 150** Cast Carbon Steel Gate Valve

API 600 Design,  
Bolted Bonnet, OS&Y,  
Screwed-in Back seat, Rising Stem,  
Non-rising Handwheel,  
Flexible Wedge

Figure NO.:  
**G1R, C00/8**  
**G1B, C00/8**

Gear Operator  
Optional 8"-24"  
Standard 26" & Larger

NPS	in	2"	2-1/2"	3"	4"	5"	6"	8"	10"	12"	14"	16"	18"	20"	24"	26"	28"	30"	32"	36"	40"	42"	48"
DN	mm	50	65	80	100	125	150	200	250	300	350	400	450	500	600	650	700	750	800	900	1000	1050	1200
L(RF)	in	7	7.5	8	9	10	10.5	11.5	13	14	15	16	17	18	20	22	24	24	26	28	30	31	34
	mm	178	191	203	229	254	267	292	330	356	381	406	432	457	508	559	610	610	660	711	762	787	864
L1(BW)	in	8.5	9.5	11.12	12	15	15.88	16.5	18	19.75	22.5	24	26	28	32	34	36	36	38	40	42	43	46
	mm	216	241	283	305	381	403	419	457	502	572	610	660	711	813	864	914	914	965	1016	1067	1092	1168
W	in	8	8	10	12	12	12	14	16	18	20	22	24	27	30	24	24	24	24	24	24	32	32
	mm	200	200	250	300	300	300	350	400	450	500	550	600	680	760	610	610	610	610	610	610	610	610
H	in	15.2	17.1	18.9	23	26.8	30.1	37.6	45.2	53.2	59.4	67	74.5	83.4	98.4	110	117	124	129	146	157	190	233
	mm	386.5	434.5	480.5	584.5	681	765	956	1149	1350.5	1508	1703	1892	2119	2500	2806	2960	3148	3281	3721	3980	4820	5920
WT(RF)	KG	19	26	35	49	64	81	127	204	291	400	486	610	788	1144	1570	1900	2540	2958	3380	4815	5300	7110
WT(BW)	KG	15	18	26	41	58	69	108	156	248	365	482	587	752	1178	1521	1838	2261	2490	3310	4840	5275	7050

**Class 300** Cast Carbon Steel Gate Valve

API 600 Design,  
Bolted Bonnet, OS&Y,  
Screwed-in Back seat, Rising Stem,  
Non-rising Handwheel,  
Flexible Wedge

Figure NO.:  
**G3R, C00/8**  
**G3B, C00/8**

Gear Operator  
Optional 8"-16"  
Standard 18" & Larger

NPS	in	2"	2-1/2"	3"	4"	5"	6"	8"	10"	12"	14"	16"	18"	20"	24"	26"	28"	30"	32"	36"	40"	42"	48"
DN	mm	50	65	80	100	125	150	200	250	300	350	400	450	500	600	650	700	750	800	900	1000	1050	1200
L-L1 (RF-BW)	in	8.5	9.5	11.12	12	15	15.88	16.5	18	19.75	30	33	36	39	45	49	53	55	60	68	76	78	88
	mm	216	241	283	305	381	403	419	457	502	762	838	914	991	1143	1245	1346	1397	1524	1727	1930	1981	2235
W	in	8	8	10	10	12	14	16	18	20	22	24	24	24	24	24	24	24	32	40	40	40	40
	mm	200	200	250	250	300	350	400	450	500	550	600	610	610	610	610	610	610	810	1000	1000	1000	1000
H	in	16.1	17.8	20	24.1	27.8	31.7	39.6	47.6	55.7	62.2	67.9	76.4	85.6	101	113	117	126	142	150	173	178	201
	mm	410	453	509	612	705	805	1005	1209	1415	1581	1725	1940	2175	2570	2870	2972	3213	3610	3821	4393	4510	5093
WT(RF)	KG	26	35	52	75	102	147	229	360	520	808	1105	1420	1705	2605	3090	3860	4948	5510	7700	10130	11270	16000
WT(BW)	KG	17	26	39	55	84	113	178	302	485	642	873	980	1510	2160	2540	3604	4414	4820	6950	9660	10780	15310

**Class 600** Cast Carbon Steel Gate Valve

API 600 Design,  
Bolted Bonnet, OS&Y,  
Screwed-in Back seat, Rising Stem,  
Non-rising Handwheel,  
Flexible Wedge

Figure NO.:  
**G6R, C00/NO.5**  
**G6J, C00/NO.5**  
**G6B, C00/NO.5**

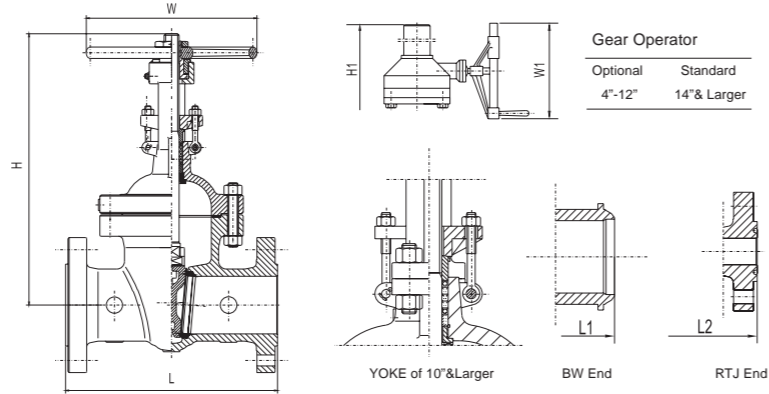

Gear Operator  
Optional Standard  
4"-12" 14"& Larger

NPS	in	2"	2-1/2"	3"	4"	5"	6"	8"	10"	12"	14"	16"	18"	20"	24"	26"	28"	30"	32"	34"	36"	40"	42"	48"
DN	mm	50	65	80	100	125	150	200	250	300	350	400	450	500	600	650	700	750	800	850	900	1000	1050	1200
L-L1 (RF-BW)	in	11.5	13	14	17	20	22	26	31	33	35	39	43	47	55	57	61	65	70	75.98	82	90	96	100
	mm	292	330	356	432	508	559	660	787	838	889	991	1092	1194	1397	1448	1549	1651	1778	1930	2082	2286	2438	2540
L2(RTJ)	in	11.62	13.12	14.12	17.12	20.12	22.12	26.12	31.12	33.12	35.12	39.12	43.12	47.25	55.38	57.5	61.5	65.5	70.6	96.61	82.6	-	-	-
	mm	295	333	359	435	511	562	663	790	841	892	994	1095	1200	1407	1461	1562	1664	1794	1946	2098	-	-	-
W	in	8	10	10	12	16	18	20	24	27	24	24	24	24	32	40	40	40	-	40	48	48	48	48
	mm	200	250	250	300	400	450	500	600	680	610	610	610	610	810	1000	1000	1000	-	1000	1200	1200	1200	1200
H	in	16.5	18.7	20.4	25.4	30.3	33	40.3	48.4	57.1	62	70.7	76.02	86.9	102	124	133	140	150	-	168	184	194	231
	mm	418	476	518	646	770	839	1024	1229	1450	1574	1797	1931	2207	2582	3150	3362	3549	3811	-	4260	4670	4921	5876
WT(RF)	KG	39	52	68	115	170	273	402	610	902	1245	1530	2030	2735	3620	5220	6050	6945	8520	9820	11890	-	16305	-
WT(BW)	KG	30	35	55	88	125	204	337	548	905	974	1345	1730	2415	3017	4295	4980	5710	7700	9000	10800	-	15120	-

**Class 1500** Cast Carbon Steel Gate Valve

API 600 Design,  
Bolted Bonnet, OS&Y,  
Screwed-in Back seat, Rising Stem,  
Non-rising Handwheel,  
Flexible Wedge

Figure NO.:  
**G15R, C00/NO.5**  
**G15J, C00/NO.5**  
**G15B, C00/NO.5**

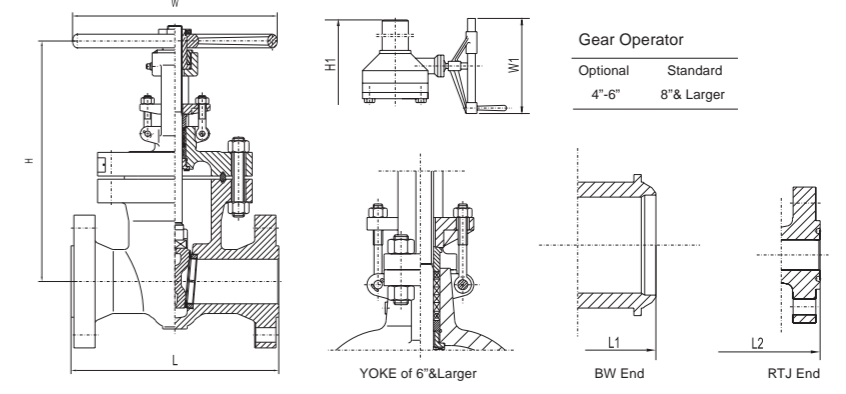

Gear Operator  
Optional Standard  
4"-6" 8"& Larger

NPS	in	2"	2-1/2"	3"	4"	5"	8"	10"	12"	14"	16"	18"	20"	24"	26"	28"	30"
DN	mm	50	65	80	100	125	200	250	300	350	400	450	500	600	650	700	750
L-L1 (RF-BW)	in	14.5	16.5	18.5	21.5	27.75	32.75	39	44.5	49.5	54.8	60.5	65.5	76.5	82	87.5	93
	mm	368	419	470	546	705	832	991	1130	1257	1384	1537	1664	1943	2083	2222.5	2362
L2(RTJ)	in	14.62	16.62	18.62	21.62	28.00	33.13	39.38	45.12	50.25	55.38	61.4	66.4	77.6	-	-	-
	mm	371	422	473	549	711	842	1000	1146	1276	1407	1559	1686	1972	-	-	-
W	in	10	12	14	20	24	18	18	24	24	24	40	40	40	47	47	47
	mm	250	300	350	500	600	458	458	610	610	610	1000	1000	1000	1200	1200	1200
H	in	19.2	22.5	23.7	27.6	38.7	45.1	54	64.3	70.8	77.3	111	121	140.5	151	158	172
	mm	487	572	603	700	984	1146	1371	1633	1798	1963	2812	3078	3570	3836	4012	4368
WT(RF)	KG	74	131	165	248	510	1040	1910	2685	4100	6200	8100	11130	13300	16500	18700	20900
WT(BW)	KG	54	105	129	197	358	761	1640	2755	3200	5300	7100	10100	12900	15700	17500	19300

**Class 900** Cast Carbon Steel Gate Valve

API 600 Design,  
Bolted Bonnet, OS&Y,  
Screwed-in Back seat, Rising Stem,  
Non-rising Handwheel,  
Flexible Wedge

Figure NO.:  
**G9R, C00/NO.5**  
**G9J, C00/NO.5**  
**G9B, C00/NO.5**

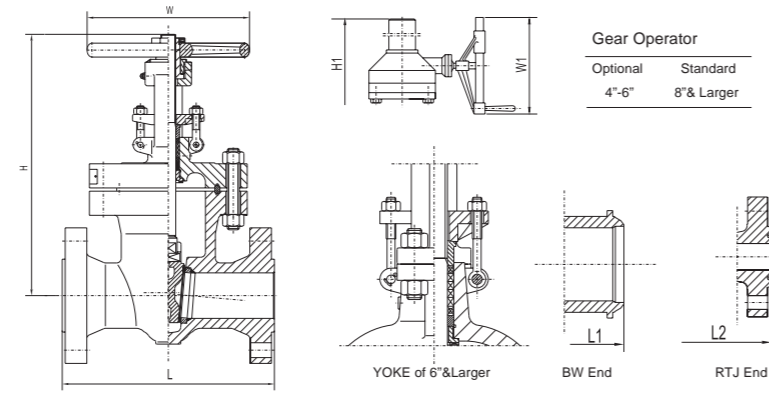

Gear Operator  
Optional Standard  
4"-6" 8"& Larger

NPS	in	2"	2-1/2"	3"	4"	5"	8"	10"	12"	14"	16"	18"	20"	24"	26"	28"	30"	32"	36"
DN	mm	50	65	80	100	125	200	250	300	350	400	450	500	600	650	700	750	800	900
L-L1 (RF-BW)	in	14.5	16.5	15	18	24	29	33	38	40.5	44.5	48	52	61	65	70	74	78	87
	mm	368	419	381	457	610	737	838	965	1029	1130	1219	1321	1549	1664	1778	1892	2004	2232
L2(RTJ)	in	14.62	16.62	15.12	18.12	24.12	29.12	33.12	38.12	40.88	44.88	48.50	52.48	61.73	-	-	-	-	-
	mm	371	422	384	460	613	740	841	968	1038	1140	1232	1333	1568	-	-	-	-	-
W	in	10	10	12	14	20	24	24	24	24	24	32	40	40	40	47	47	47	
	mm	250	250	300	350	500	600	610	610	610	610	810	1000	1000	1000	1200	1200	1200	
H	in	19.6	21.5	22.6	26.7	35.4	43.4	53	59.8	74.9	80.7	87	95	108.4	111.5	114.8	118	121.4	128
	mm	498	547	573	678	900	1103	1345	1520	1902	2051	2212	2417	2750	2833	2916	3000	3083	3250
WT(RF)	KG	74	92	101	172	335	640	1100	1360	2250	2850	3870	4860	6100	7300	7600	9800	11950	15000
WT(BW)	KG	54	65	70	110	258	498	810	1228	2009	2563	3300	4050	6120	5500	6900	9000	11000	13500

**Class 2500** Cast Carbon Steel Gate Valve

API 600 Design,  
Bolted Bonnet, OS&Y, Rising Stem,  
Non-rising Handwheel,  
Flexible Wedge

Figure NO.:  
**G25R, C00/NO.5**  
**G25J, C00/NO.5**  
**G25B, C00/NO.5**

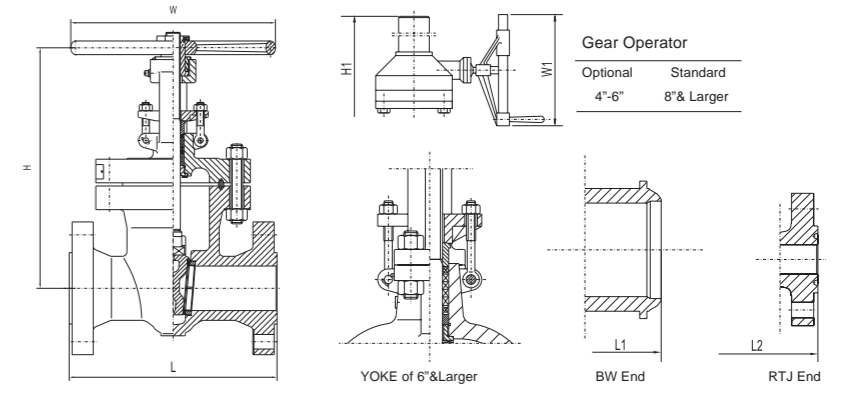

Gear Operator  
Optional Standard  
4"-6" 8"& Larger

NPS	in	2"	2-1/2"	3"	4"	5"	8"	10"	12"	14"	16"	18"	20"	24"
DN	mm	50	65	80	100	125	200	250	300	350	400	450	500	600
L-L1 (RF-BW)	in	17.75	20	22.75	26.5	36	40.25	50	56	62	68	74	80	92
	mm	451	508	578	673	914	1022	1270	1422	1575	1727	1879	2031	2335
L2(RTJ)	in	17.88	20.25	23.00	26.88	36.50	40.88	50.88	56.88	-	-	-	-	-
	mm	454	514	584	683	927	1038	1292	1445	-	-	-	-	-
W	in	14	18	18	20	24	24	24	24	32	32	40	40	40
	mm	350	450	450	500	610	610	610	610	810	810	1000	1000	1000
H	in	22.2	22.2	22.9	34.3	57.1	63.4	81.7	89.8	319.7	400	100.6	112.6	136.6
	mm	563	563	582	870	1450	1610	2076	2281	1945	2250	2555	2860	3470
WT(RF)	KG	130	200	245	490	1600	2450	4570	6100	8120	10170	12100	14700	16500
WT(BW)	KG	95	150	175	375	1310	2010	3800	5200	7510	9730	10900	12100	14700



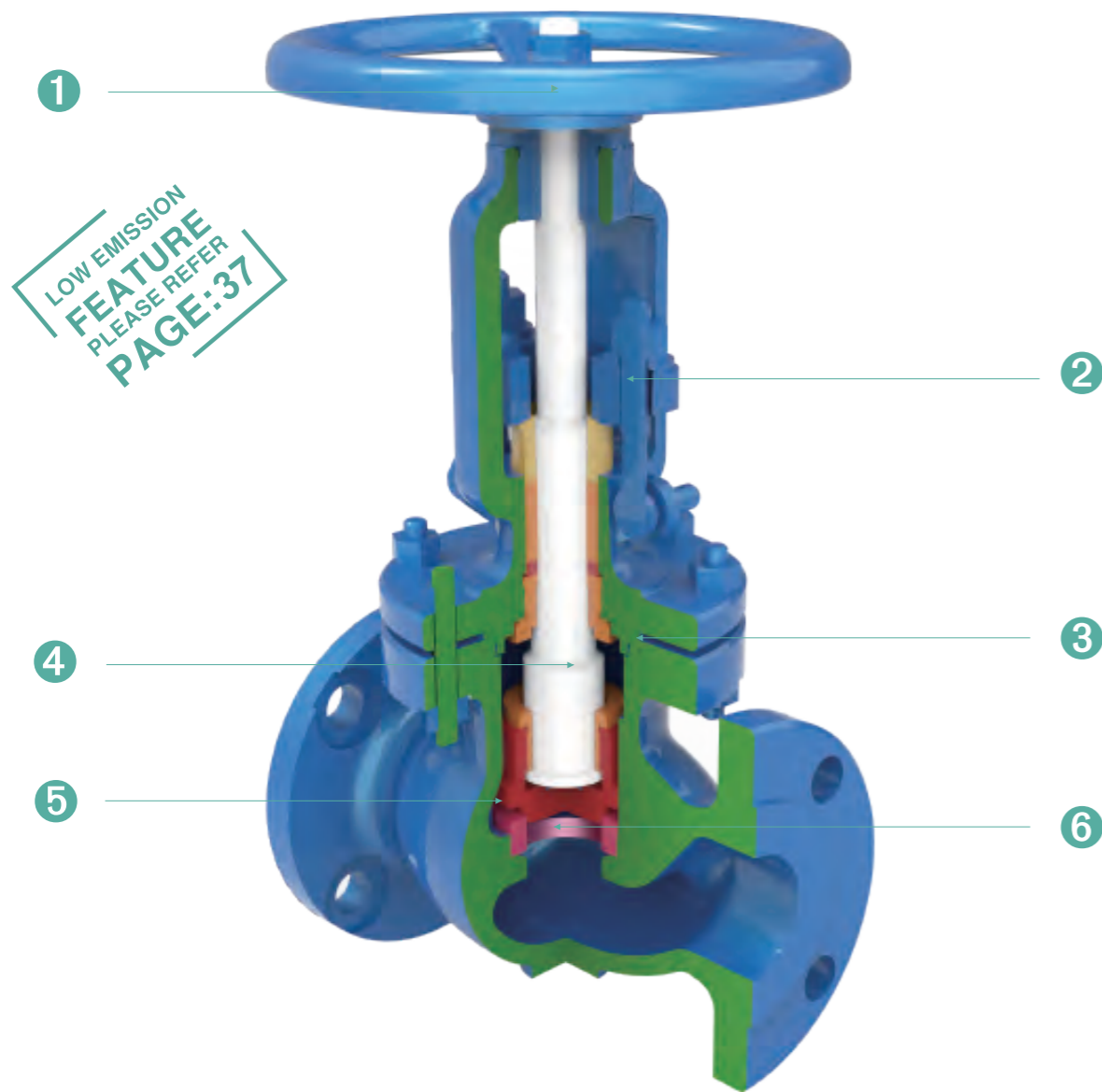

- 1 Impact handwheel supplied at manufacturer's option or on customer request.
- 2 Gland eyebolts are mounted to swing aside to facilitate packing maintenance.
- 3 Male and female bonnet joints for Class 150 to 600 valves, and ring joint for the Class 900 & above valves or as an option for Class 600 valves on customer request.
- 4 Anti blow-out stem design with conical backseat surface to permit repacking of valve in the fully open position.
- 5 Plug seat surface is standard disc design as well as spherical, parabola or flat seating surface is optional on customer request.
- 6 Seat face with stellite 6 is standard design.

Part	Standard	Low Temperature Service	High Temperature Service	Stainless Steel	Sour Service
BODY	ASTM A216-WCB	ASTM A352-LCC	ASTM A217-WC9	ASTM A351-CF8M	ASTM A216-WCB
BONNET	ASTM A216-WCB	ASTM A352-LCC	ASTM A217-WC9	ASTM A351-CF8M	ASTM A216-WCB
DISC	ASTM A216-F6a or ASTM A105/ER410	ASTM A182-F316	ASTM A182-F22/STL.OVERLAY	ASTM A182-F316	ASTM A182-F6a
STEM NUT	ASTM A439 D-2 or BRONZE	ASTM A439 D-2 or BRONZE	ASTM A439 D-2 or BRONZE	ASTM A439 D-2 or BRONZE	ASTM A439 D-2 or BRONZE
GLAND FLANGE	ASTM A105N	ASTM A350 LF2	ASTM A105N	ASTM A182-F316	ASTM A105N
HANDWHEEL	DUCTILEIRON	DUCTILEIRON	DUCTILEIRON	DUCTILEIRON	DUCTILEIRON
SEAT RING	ASTMA105/STL. OVERLAY	ASTM A182-F316/STL. OVERLAY	ASTM A182-F22/STL. OVERLAY	ASTM A182-F316/STL. OVERLAY	ASTMA105/STL. OVERLAY
STEM	ASTM A182-F6a	ASTM A182-F316	ASTM A182-F6a	ASTM A182-F316	ASTM A182-F6a-NC
BACK SEAT	ASTM A276-420	ASTM A276-316	ASTM A276-420	ASTM A276-316	ASTM A276-420-NC
GLAND	ASTM A276-420	STAINLESS STEEL	ASTM A276-420	ASTM A276-316	ASTM A276-420-NC
SPACE RING	ASTM A276-420	ASTM A276-316	ASTM A276-420	ASTM A276-316	ASTM A276-420-NC
DISC NUT	ASTM A276-420	ASTM A276-316	ASTM A276-420	ASTM A276-316	ASTM A276-420-NC
STEM WASHER	ASTM A276-430	N/A	ASTM A276-430	ASTM A276-316	ASTM A276-420-NC
HANDWHEEL WASHER	CARBON STEEL	CARBON STEEL	CARBON STEEL	STAINLESS STEEL	CARBON STEEL
BONNET GASKET	SOFT STEEL	ASTM A276-316	SOFT STEEL	ASTM A276-316	SOFT STEEL
PACKING	GRAPHITE+SS	GRAPHITE+SS	GRAPHITE+SS	GRAPHITE+SS	GRAPHITE+SS
BONNET STUD	ASTM A193-B7	ASTM A320-L7M	ASTM A193-B16	ASTM A193-B8 Class2	ASTM A193-B7M
BONNET NUT	ASTM A194-2H	ASTM A194-7M	ASTM A194-7	ASTM A194-8	ASTM A194-2HM
EYE BOLT	ASTM A193-B7	ASTM A320-L7M	ASTM A193-B16	ASTM A193-B8	ASTM A193-B7M
GLAND NUT	ASTM A194-2H	ASTM A194-7M	ASTM A194-7	ASTM A194-8	ASTM A194-2HM
HANDWHEEL NUT	CARBON STEEL	CARBON STEEL	CARBON STEEL	STAINLESS STEEL	CARBON STEEL
EYE BOLT PIN	CARBON STEEL	STAINLESS STEEL	STAINLESS STEEL	STAINLESS STEEL	CARBON STEEL
NAME PLATE	STAINLESS STEEL	STAINLESS STEEL	STAINLESS STEEL	STAINLESS STEEL	STAINLESS STEEL

**Class 150** Cast Carbon Steel Globe Valve

API 623 Design,  
Bolted Bonnet, OS&Y,  
Screwed-in Back seat,  
Rising Stem and Handwheel,  
Swivel Disc

Figure NO.:  
GL1R, C00/NO.8  
GL1B, C00/NO.8

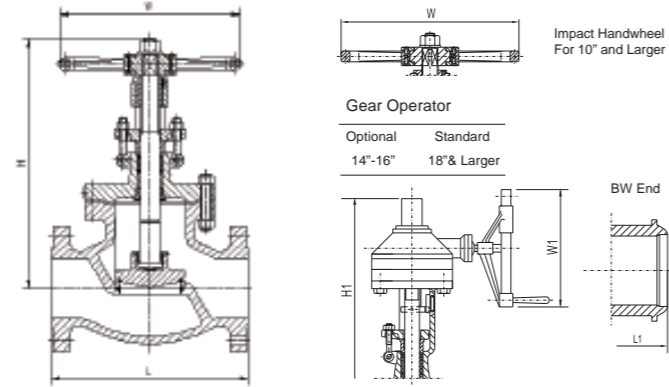

NPS	in	2"	2-1/2"	3"	4"	5"	6"	8"	10"	12"	14"	16"	18"	20"	24"
DN	mm	50	65	80	100	125	150	200	250	300	350	400	450	500	600
L-L1 (RF-BW)	in	8	8.5	9.5	11.5	14	16	19.5	24.5	27.5	31	36	38.5	38.5	51
	mm	203	216	241	292	356	406	495	622	699	787	914	978	978	1295
W	in	8	10	10	12	14	14	16	20	20	22	26	24	24	31.9
	mm	200	250	250	300	350	350	400	500	500	560	650	610	610	810
H	in	13.3	14.7	15.6	18.7	19.6	20.6	23.1	29.1	33.9	37.4	39.2	44.9	49.7	60
	mm	338	373	396	476	497	524	588	738	862	950	994	1140	1262	1524
WT(RF)	KG	21	29	35	58	78	104	162	289	485	550	724	1400	2600	3700
WT(BW)	KG	17	20	30	47	71	86	138	219	362	491	650	1250	2300	3250

**Class 300** Cast Carbon Steel Globe Valve

API623 Design,  
Bolted Bonnet, OS&Y,  
Screwed-in Back seat,  
Rising Stem and Handwheel,  
Swivel Disc

Figure NO.:  
GL3R, C00/NO.8  
GL3B, C00/NO.8

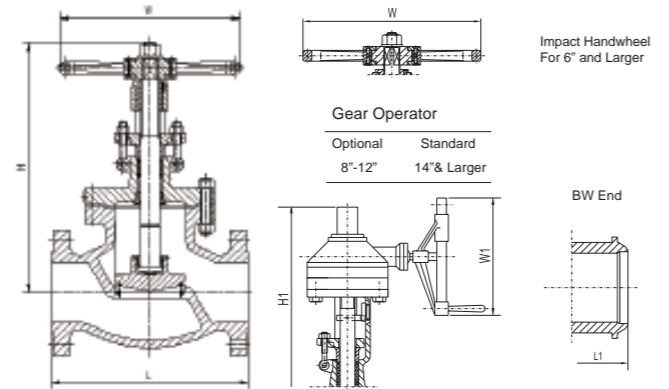

NPS	in	2"	2-1/2"	3"	4"	5"	6"	8"	10"	12"	14"	16"	18"	20"
DN	mm	50	65	80	100	125	150	200	250	300	350	400	450	500
L-L1 (RF-BW)	in	10.5	11.5	12.5	14	15.75	17.5	22	24.5	28	33	34	38.5	40
	mm	267	292	318	356	400	445	559	622	711	838	864	978	1016
W	in	8	10	10	14	18	20	22	24	26	24	24	38.5	40
	mm	200	250	250	350	450	500	560	600	650	610	610	610	810
H	in	13.9	15.3	16.6	19.5	22.7	26.6	35.9	37.4	40.6	44.5	51.6	57.5	64.3
	mm	353.5	388.5	420.5	495.5	576.5	674.5	911.5	949	1032	1130	1310	1460	1632
WT(RF)	KG	26	38	51	76	125	173	297	500	724	1125	1650	2700	3650
WT(BW)	KG	21	29	38	59	104	137	237	432	632	975	1450	2400	3200

**Class 600** Cast Carbon Steel Globe Valve

API 623 Design,  
Bolted Bonnet, OS&Y,  
Screwed-in Back seat,  
Rising Stem and Handwheel,  
Swivel Disc

Figure NO.:  
GL6R, C00/NO.8  
GL6J, C00/NO.8  
GL6B, C00/NO.8

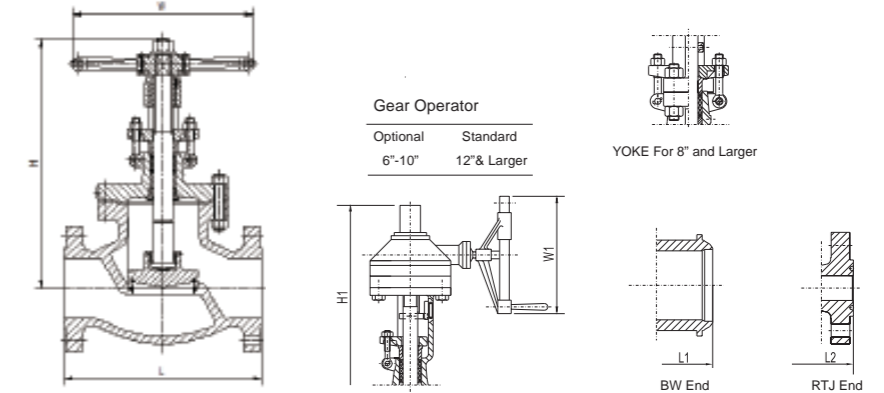

NPS	in	2"	2-1/2"	3"	4"	5"	6"	8"	10"	12"	14"	16"	18"
DN	mm	50	65	80	100	125	150	200	250	300	350	400	450
L-L1 (RF-BW)	in	11.5	13	14	17	20	22	26	31	33	35	39	43
	mm	292	330	356	432	508	559	660	787	838	889	991	1092
L2(RTJ)	in	11.62	13.12	14.12	17.12	20.12	22.12	26.12	31.12	33.12	35.12	39.12	43.1
	mm	295	333	359	435	511	562	663	790	841	892	994	1095
W	in	10	10	14	18	20	22	24	28	24	24	30	32
	mm	250	250	350	450	500	560	600	700	610	610	762	810
H	in	15.6	17.6	19.5	23.6	27.6	31.1	39.9	46.5	55	57.1	63.4	70.9
	mm	396.5	446	495.5	599	700	791	1014	1180	1397	1450	1610	1801
WT(RF)	KG	37	50	62	150	187	294	543	1006	1350	1620	2160	3300
WT(BW)	KG	30	40	58	132	142	227	460	729	1060	1330	1750	2800

**Class 900** Cast Carbon Steel Globe Valve

API 623 Design,  
Bolted Bonnet, OS&Y,  
Screwed-in Back seat,  
Rising Stem and Handwheel,  
Swivel Disc

Figure NO.:  
GL9R, C00/NO.5  
GL9J, C00/NO.5  
GL9B, C00/NO.5

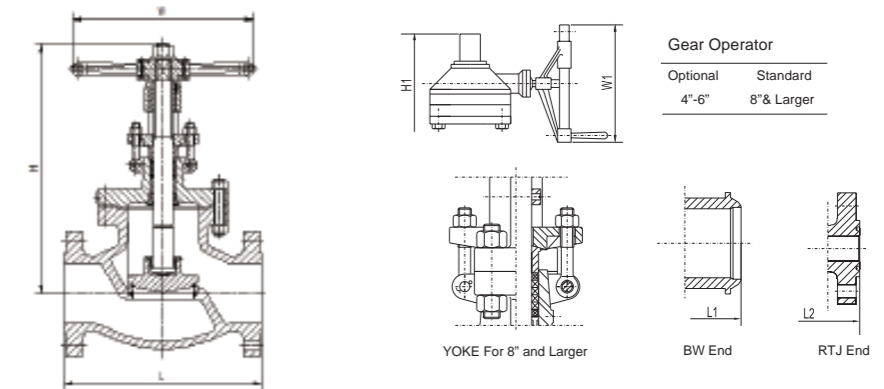

NPS	in	2"	2-1/2"	3"	4"	6"	8"	10"	12"	14"	16"
DN	mm	50	65	80	100	150	200	250	300	350	400
L-L1 (RF-BW)	in	14.5	16.5	15	18	24	29	33	38	40.5	44.5
	mm	368	419	381	457	610	737	838	965	1029	1130
L2(RTJ)	in	14.62	16.62	15.12	18.12	24.12	29.12	33.1	38.1	40.9	44.9
	mm	371	422	384	460	613	740	841	968	1038	1140
W	in	14	14	18	20	24	24	24	31.9	31.9	31.9
	mm	350	350	450	500	610	610	610	810	810	810
H	in	23.2	26	27.5	31.3	43.6	46.6	58.2	69.1	76.1	87
	mm	590	660	699	795	1108	1184	1479	1755	1934	2210
WT(RF)	KG	95	138	110	197	435	720	1070	1920	2670	3520
WT(BW)	KG	75	85	112	158	360	597	890	1690	2390	3170

**Class 1500**

Cast Carbon Steel Globe Valve

API623 Design,  
Bolted Bonnet, OS&Y,  
Screwed-in Back seat,  
Rising Stem and Handwheel,  
Swivel Disc

Figure NO.:  
GL15R, C00/NO.5  
GL15J, C00/NO.5  
GL15B, C00/NO.5

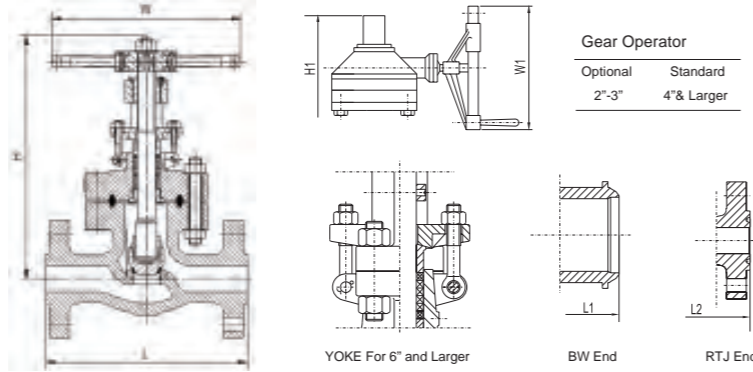

Gear Operator  
Optional 2"-3"  
Standard 4"& Larger

NPS	in	2"	2-1/2"	3"	4"	6"	8"	10"	12"
DN	mm	50	65	80	100	150	200	250	300
L-L1 (RF-BW)	in	14.5	16.5	18.5	21.5	27.75	32.75	39	44.5
	mm	368	419	470	546	705	832	991	1130
L2(RTJ)	in	14.62	16.62	18.62	21.62	28.00	33.13	39.4	45.1
	mm	371	422	473	549	711	842	1000	1146
W	in	14	14	20	22	24	24	31.9	31.9
	mm	350	350	500	560	610	610	810	810
H	in	21.7	22.5	22.9	31.3	50.3	77.2	96.5	114.3
	mm	550	572	582	795	1278	1960	2450	2904
WT(RF)	KG	85	138	215	350	560	990	1530	2570
WT(BW)	KG	75	112	129	299	462	830	1330	2270

**Class 2500**

Cast Carbon Steel Globe Valve

API623 Design,  
Bolted Bonnet, OS&Y,  
Screwed-in Back seat,  
Rising Stem and Handwheel,  
Swivel Disc

Figure NO.:  
GL25R, C00/NO.5  
GL25J, C00/NO.5  
GL25B, C00/NO.5

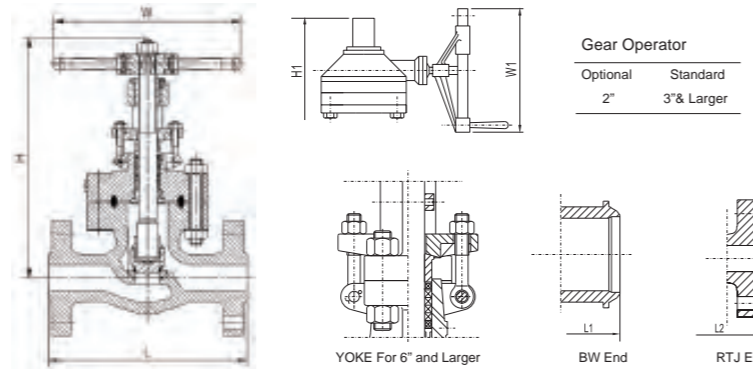

Gear Operator  
Optional 2"  
Standard 3"& Larger

NPS	in	2"	2-1/2"	3"	4"	6"	8"	10"
DN	mm	50	65	80	100	150	200	250
L-L1 (RF-BW)	in	17.75	20	22.75	26.5	36	40.25	50
	mm	451	508	578	673	914	1022	1270
L2(RTJ)	in	17.88	20.25	23.00	26.88	36.50	40.88	50.9
	mm	454	514	584	683	927	1038	1292
W	in	16	20	22	24	24	24	31.9
	mm	400	500	560	610	610	610	810
H	in	28.3	31.5	34.8	49.6	75	97	122.4
	mm	720	800	885	1260	1905	2465	3108
WT(RF)	KG	176	264	308	759	1990	4390	5290
WT(BW)	KG	141	214	238	644	1700	3950	4390

LOW EMISSION  
FEATURE  
PLEASE REFER  
PAGE:37

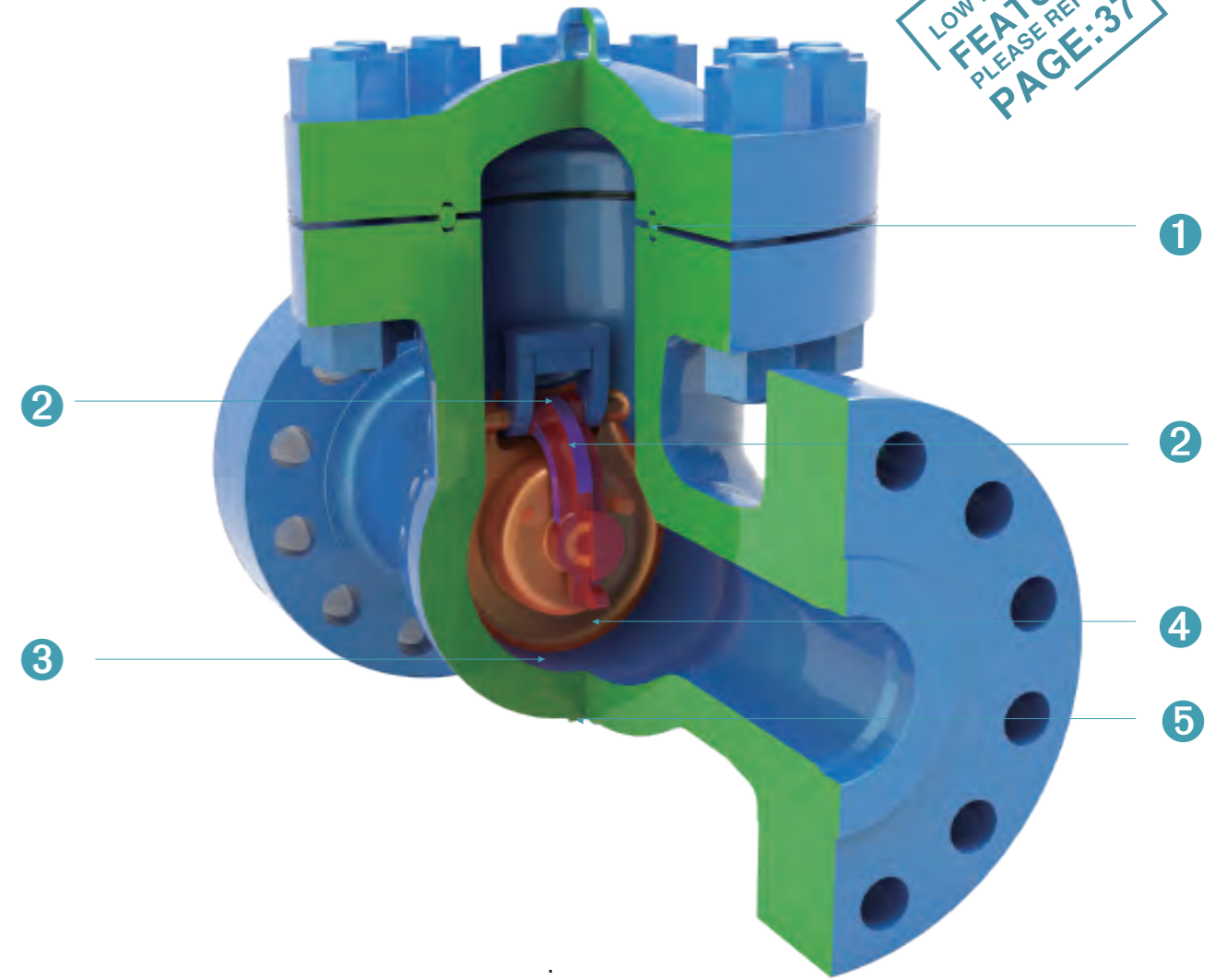

- 1 Spiral wound gasket for Class 150 to Class 600 valves, and ring joint for Class 900 & above valves or as an option for the Class 600 valves on customer request.
- 2 A hinge and hinge pin provided and mounted so as to permit full movement of the disc.
- 3 Standard renewable seal welded seat with stellite 6 while optional screwed-in seat.
- 4 Standard swing disc type, used in horizontal position for liquid service application or used in vertical position where liquid flow from bottom to top.
- 5 Provision of standard bosses for a drain tapping at location G at the lower part of body centerline. Additional bosses conform to customer requirements.

Part	Standard	Low Temperature Service	High Temperature Service	Stainless Steel	Sour Service
BODY	ASTM A216-WCB	ASTM A352-LCC	ASTM A217-WC9	ASTM A351-CF8M	ASTM A216-WCB
COVER	ASTM A216-WCB	ASTM A352-LCC	ASTM A217-WC9	ASTM A351-CF8M	ASTM A216-WCB
DISC	ASTM A217-CA15(4" & Smaller) & ASTM A216-WCB/ER410	ASTM A352-LCC/316 OVERLAY	ASTM A217-WC9/STL.OVERLAY	ASTM A351-CF8M	ASTM A217-CA15-NC(4" & Smaller) & ASTM A216-WCB/ER410-NC
HINGE	ASTM A216-WCB	ASTM A352-LCC	ASTM A217-WC9	ASTM A351-CF8M	ASTM A216-WCB
SEAT RING	ASTM A105/STL. OVERLAY	ASTM A182-F316/STL. OVERLAY	ASTM A182-F22/STL. OVERLAY	ASTM A182-F316/STL. OVERLAY	ASTM A105/STL. OVERLAY
HINGE PIN	ASTM A276-410	ASTM A276-316	ASTM A276-410	ASTM A276-316	ASTM A276-410-NC
CONNECTING BLOCK	ASTM A216-WCB	ASTM A352-LCC	ASTM A217-WC9	ASTM A351-CF8M	ASTM A216-WCB
WASHER	316LSS	316LSS	316LSS	316LSS	316LSS
BOLT	316LSS	316LSS	316LSS	316LSS	316LSS
DISC NUT	ASTM A276-420	ASTM A276-316	ASTM A276-420	ASTM A276-316	STAINLESS STEEL
WASHER	ASTM A276-420	ASTM A276-316	ASTM A276-420	ASTM A276-316	STAINLESS STEEL
DISC SPLIT PIN	ASTM A276-420	ASTM A276-316	ASTM A276-420	ASTM A276-316	STAINLESS STEEL
BONNET RING JOINT	SOFT STEEL	ASTM A276-316	ASTM A276-304	ASTM A276-316	SOFT STEEL
BONNET STUD	ASTM A193-B7	ASTM A320-L7M	ASTM A193-B16	ASTM A193-B8 Class2	ASTM A193-B7M
BONNET NUT	ASTM A194-2H	ASTM A194-7M	ASTM A194-7	ASTM A194 8	ASTM A194-2HM
NAME PLATE	STAINLESS STEEL	STAINLESS STEEL	STAINLESS STEEL	STAINLESS STEEL	STAINLESS STEEL

**Class 150** Cast Carbon Steel Check Valve

API 594 Design,  
Bolted Cover,  
Swivel Type Disc

Figure NO.:  
**S1R, C00/NO.8**  
**S1B, C00/NO.8**

NPS	in	2"	2-1/2"	3"	4"	5"	6"	8"	10"	12"	14"	16"	18"	20"	24"	26"	28"	30"	32"	36"	40"	42"	48"
DN	mm	50	65	80	100	125	150	200	250	300	350	400	450	500	600	650	700	750	800	900	1000	1050	1200
L-L1 (RF-BW)	in	8	8.5	9.5	11.5	13	14	19.5	24.5	27.5	31	34	38.5	38.5	51	51	57	60	68	77	85	89	101
	mm	203	216	241	292	330	356	495	622	699	787	864	978	978	1295	1295	1448	1524	1727	1956	2159	2261	2566
H	in	5.9	6.6	6.7	8	9.1	11.7	13.8	15.3	17.2	18.8	20.7	22.9	24.7	34.6	35.8	36.8	38.2	49.2	54.2	55.5	57.8	64.6
	mm	151	168	171	204	230	297	352	390	438	477	525	582	627	880	910	935	970	1250	1377	1410	1468	1642
WT(RF)	KG	15	20	28	42	57	79	125	252	374	480	642	784	934	1336	1526	1936	2020	2430	3738	-	5910	-
WT(BW)	KG	10	15.5	21.2	32	45	64	103	189	327	423	541	696	829	1276	1250	1680	1945	2062	3256	-	5246	-

**Class 300** Cast Carbon Steel Check Valve

API 594 Design,  
Bolted Cover,  
Swivel Type Disc

Figure NO.:  
**S3R, C00/NO.8**  
**S3B, C00/NO.8**

NPS	in	2"	2-1/2"	3"	4"	5"	6"	8"	10"	12"	14"	16"	18"	20"	24"	26"	28"	30"	32"	36"	40"	42"	48"
DN	mm	50	65	80	100	125	150	200	250	300	350	400	450	500	600	650	700	750	800	900	1000	1050	1200
L-L1 (RF-BW)	in	10.5	11.5	12.5	14	15.75	17.5	21	24.5	28	33	34	38.5	40	53	53	59	62.75	68	82	96	103	124
	mm	267	292	318	356	400	445	533	622	711	838	864	978	1016	1346	1346	1499	1594	1727	2083	2438	2617	3151
H	in	6.9	7.3	8.5	10.2	12	12.5	15	17.1	20.1	22.1	23.5	26.6	28.7	33.9	36.6	45.8	50.0	50.0	59.4	68.9	73.6	87.8
	mm	176	185	216	259	304	317	380	434	511	561	596	675	730	860	930	1163	1270	1270	1510	1750	1870	2230
WT(RF)	KG	20	26	40	65	82	118	223	310	494	702	882	1094	1382	2162	2375	2995	3680	-	6280	-	-	-
WT(BW)	KG	14	23	30	48	60	92	170	245	360	520	565	850	1004	1842	1995	2495	2780	-	5514	-	-	-

**Class 600**

Cast Carbon Steel Check Valve

API 594 Design,  
Bolted Cover,  
Swivel Type Disc

Figure NO.:  
S6R, C00/NO.8  
S6B, C00/NO.8

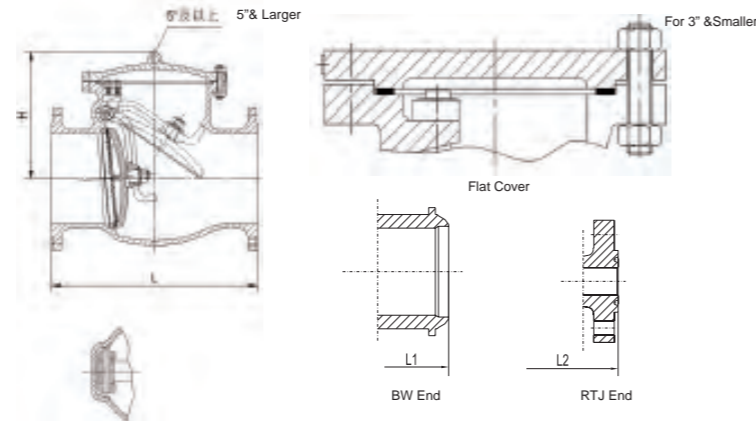

NPS	in	2"	2-1/2"	3"	4"	5"	6"	8"	10"	12"	14"	16"	18"	20"	24"	26"	28"	30"	32"	36"	40"	42"	48"
DN	mm	50	65	80	100	125	150	200	250	300	350	400	450	500	600	650	700	750	800	900	1000	1050	1200
L-L1 (RF-BW)	in	11.5	13	14	17	20	22	26	31	33	35	39	43	47	55	57	63	65	70	82	90	96	100
	mm	292	330	356	432	508	559	660	787	838	889	991	1092	1194	1397	1448	1600	1651	1778	2083	2286	2438	2540
L2(RTJ)	in	11.62	13.12	14.12	17.12	20.12	22.12	26.12	31.12	33.12	35.12	39.12	43.12	47.25	55.38	57.5	63.5	65.5	70.6	82.6	-	-	-
	mm	295	333	359	435	511	562	663	790	841	892	994	1095	1200	1407	1461	1613	1664	1794	2099	-	-	-
H	in	7.2	8.3	9.1	10.4	11.6	14.7	16.8	20.4	22.4	24.5	26.8	29.6	38.4	43.7	46.9	52.1	53.8	60.7	67.0	70.9	85.5	
	mm	184	210	232	263	295	374	426	517	569	622	680	752	975	1111	1110	1192	1324	1367	1542	1702	1800	2171
WT(RF)	KG	30	43	55	94	155	228	396	530	730	1000	1430	1510	2258	3440	4255	5075	6130	-	9905	-	-	-
WT(BW)	KG	23	35	43	85	120	160	233	455	616	840	1030	1365	1888	2950	3619	4360	5338	-	8895	-	-	-

**Class 900**

Cast Carbon Steel Check Valve

API 594 Design,  
Bolted Cover,  
Swivel Type Disc

Figure NO.:  
S9R, C00/NO.8  
S9B, C00/NO.8  
S9J, C00/NO.8

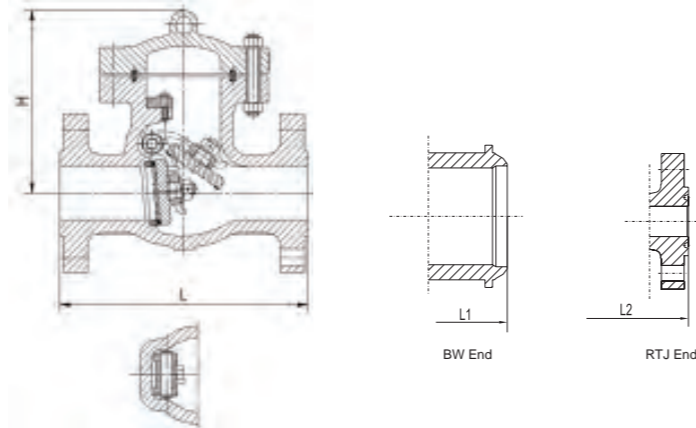

NPS	in	2"	2-1/2"	3"	4"	6"	8"	10"	12"	14"	16"	18"	20"	24"	26"	28"	30"	32"	36"
DN	mm	50	65	80	100	150	200	250	300	350	400	450	500	600	650	700	750	800	900
L-L1 (RF-BW)	in	14.5	16.5	15	18	24	29	33	38	40.5	44.5	48.0	52.0	61.0	65.0	69.0	73.0	77.0	84.9
	mm	368	419	381	457	610	737	838	965	1029	1130	1219	1321	1549	1651	1753	1854	1956	2156
L2(RTJ)	in	14.62	16.62	15.12	18.12	24.12	29.12	33.12	38.12	40.88	44.88	48.5	52.5	61.7	65.9	69.9	73.9	-	-
	mm	371	422	384	460	613	740	841	968	1038	1140	1232	1333	1568	1673	1775	1876	-	-
H	in	11.7	11.8	11.8	12.9	17.4	19.8	26.1	30.5	30.8	33	33.0	36.7	36.4	44.1	54.0	59.9	65.8	71.7
	mm	296	300	300	327	441	502	664	775	782	838	839	932	924	1121	1372	1521	1671	1821
WT(RF)	KG	70	100	96	150	286	542	815	1125	1310	1845	2320	3500	5200	6600	-	-	-	-
WT(BW)	KG	60	86	80	115	210	404	600	922	1084	1528	1945	3035	4650	5630	-	-	-	-

**Class 1500**

Cast Carbon Steel Check Valve

API 594 Design,  
Bolted Cover,  
Swivel Type Disc

Figure NO.:  
S15R, C00/NO.8  
S15B, C00/NO.8  
S15J, C00/NO.8

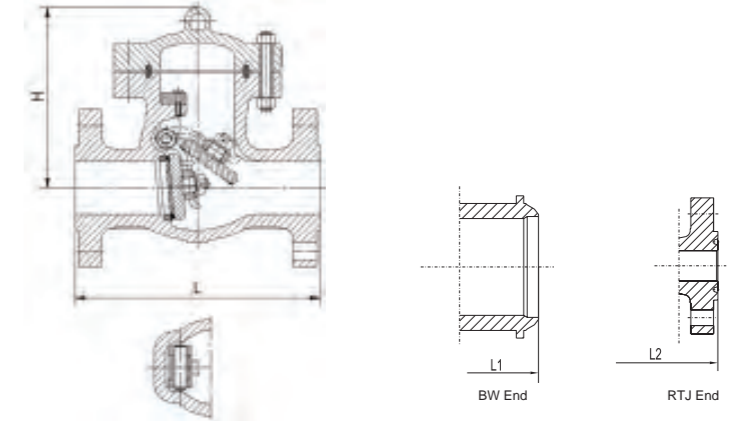

NPS	in	2"	2-1/2"	3"	4"	6"	8"	10"	12"	14"	16"	18"	20"	24"	26"	28"	30"
DN	mm	50	65	80	100	150	200	250	300	350	400	450	500	600	650	700	750
L-L1 (RF-BW)	in	14.5	16.5	18.5	21.5	27.75	32.75	39	44.5	49.5	54.5	60.5	65.5	76.5	82.0	87.5	83.0
	mm	368	419	470	546	705	832	991	1130	1257	1384	1537	1664	1943	2083	2222.5	2362
L2(RTJ)	in	14.62	16.62	18.62	21.62	28.00	33.13	39.38	45.12	50.25	55.38	61.4	66.4	77.6	-	-	-
	mm	371	422	473	549	711	842	1000	1146	1276	1407	1559	1686	1972	-	-	-
H	in	11.7	11.8	13.4	16.2	20.1	26.8	29.8	33.7	37.4	40.1	45.2	50.6	60.6	70.6	80.7	90.7
	mm	296	300	341	412	511	680	756	857	950	1020	1147	1284	1539	1794	2049	2304
WT(RF)	KG	70	100	135	216	500	818	1560	2015	2780	3880	5100	6200	-	-	-	-
WT(BW)	KG	56	68	75	150	406	670	1245	1639	2150	3140	4220	5430	-	-	-	-

**Class 2500**

Cast Carbon Steel Check Valve

API 594 Design,  
Bolted Cover,  
Swivel Type Disc

Figure NO.:  
S25R, C00/NO.8  
S25B, C00/NO.8  
S25J, C00/NO.8

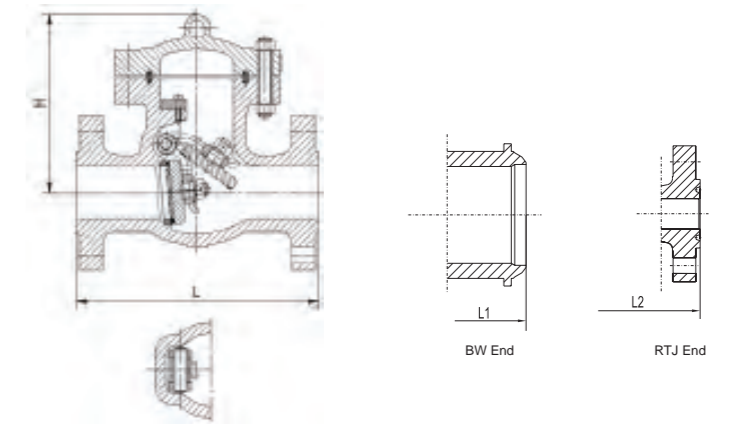

NPS	in	2"	2-1/2"	3"	4"	6"	8"	10"	12"	14"	16"	18"	20"	24"
DN	mm	50	65	80	100	150	200	250	300	350	400	450	500	600
L-L1 (RF-BW)	in	17.75	20	22.75	26.5	36	40.25	50	56	62.0	68.0	73.9	79.9	91.9
	mm	451	508	578	673	914	1022	1270	1422	1575	1727	1877	2029	2334
L2(RTJ)	in	17.87	20.25	23.00	26.88	36.50	40.87	50.88	56.88	-	-	-	-	-
	mm	454	514	584	683	927	1038	1292	1445	-	-	-	-	-
H	in	16.4	16.5	17.4	18.9	20.1	28	33.5	39.4	47.2	51.2	55.1	59.1	63.0
	mm	416	419	441	479	511	711	851	1000	1200	1300	1400	1500	1600
WT(RF)	KG	145	210	224	365	806	1525	2295	-	-	-	-	-	-
WT(BW)	KG	110	160	170	330	665	1216	1697	-	-	-	-	-	-

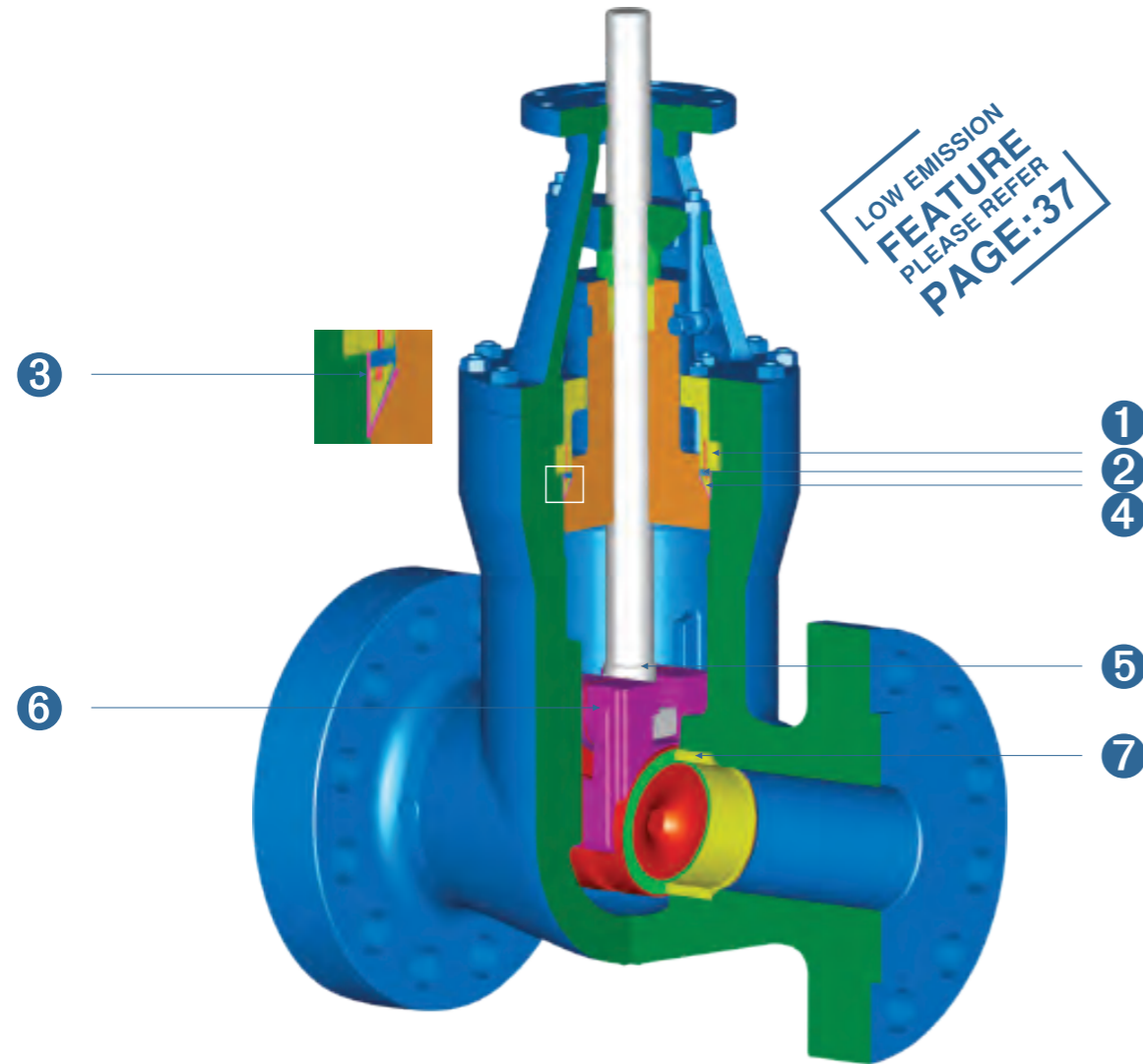

- 1 Separated rings absorb the thrust along the stem applied by the internal pressure.
- 2 Sealing rings are used to withstand pressure and prevent deformation of the gaskets.
- 3 Stainless steel inlay to ensure soundness and corrosion-resistance in the critical body sealing zone for carbon and alloy steel valves.
- 4 Mild steel gasket seal to provide large contact area for perfect sealing.
- 5 Blowout proof stem design features tapered sealing surface which contacts against bonnet backseat when the valve is fully open.
- 6 Flexible wedge can compensate for seat face distortion and body deformation due to pipe stress.
- 7 Seat ring with stellite 6 overlay is standard design and installed with seal weld.

Part	Standard	Stainless Steel	High Temperature Service		
			ASTM A217-WC6	ASTM A217-WC9	ASTM A217-C12A
BODY	ASTM A216-WCB	ASTM A351-CF8M	ASTM A217-WC6	ASTM A217-WC9	ASTM A217-C12A
BONNET	ASTM A105	ASTM A182-F316	ASTM A182-F11	ASTM A182-F22	ASTM A217-C12A
WEDGE	ASTM A216-WCB/ER410&ASTM A217-CA15	ASTM A351-CF8M/STL. OVERLAY	ASTM A217-WC6/ER410& ASTM A217-CA15	ASTM A217-WC9/ER410& ASTM A217-CA15	ASTM A217-C12A/ER410
STEM NUT	ASTM A439 D-2 or BRONZE	ASTM A439 D-2 or BRONZE	ASTM A439 D-2 or BRONZE	ASTM A439 D-2 or BRONZE	ASTM A439 D-2 or BRONZE
GLAND FLANGE	ASTM A105N	ASTM A182 F316	ASTM A182 F11	ASTM A182 F11	ASTM A182 F11
HANDWHEEL	DUCTILE IRON	DUCTILE IRON	DUCTILE IRON	DUCTILE IRON	DUCTILE IRON
SEAT RING	ASTM A105/STL. OVERLAY	ASTM A182-F316/STL. OVERLAY	ASTM A182-F11/STL. OVERLAY	ASTM A182-F22/STL. OVERLAY	ASTM A182-F6a/STL. OVERLAY
STEM	ASTM A182-F6a	ASTM A182-F316	ASTM A182-F6a	ASTM A182-F6a	ASTM A182-F6a
BONNET SEAL RING	GRAPHITE	GRAPHITE	GRAPHITE	GRAPHITE	GRAPHITE
GLAND	ASTM A276-420	ASTM A276-316	ASTM A276-420	ASTM A276-420	ASTM A276-420
RETAINING NUT FOR STEM NUT	CARBON STEEL	CARBON STEEL	CARBON STEEL	CARBON STEEL	CARBON STEEL
YOKE	ASTM A216-WCB	ASTM A351-CF8	ASTM A216-WCB& ASTM A217-WC6	ASTM A216-WCB& ASTM A217-WC6	ASTM A216-WCB
PACKING	GRAPHITE+SS	GRAPHITE+SS	GRAPHITE+SS	GRAPHITE+SS	GRAPHITE+SS
BONNET SEPARATE RING	CARBON STEEL	ASTM A276-420	ANSI 4140	ANSI 4140	ANSI 4140
CLIPPING RING	ASTM A216-WCB	ASTM A351-CF8	ASTM A217-WC6	ASTM A217-WC6	ASTM A276-420
HANDWHEEL NUT	CARBON STEEL	STAINLESS STEEL	CARBON STEEL	CARBON STEEL	CARBON STEEL
BONNET STUD	ASTM A193-B7	ASTM A193-B8	ASTM A193-B16	ASTM A193-B16	ASTM A193-B16
BONNET NUT	ASTM A194-2H	ASTM A194-8	ASTM A194-4	ASTM A194-4	ASTM A194-4
YOKE STUD	ASTM A193-B7	ASTM A193-B8	ASTM A193-B16	ASTM A193-B16	ASTM A193-B16
YOKE NUT	ASTM A194-2H	ASTM A194-8	ASTM A194-4	ASTM A194-4	ASTM A194-4
GLAND EYE BOLT	ASTM A193-B7	ASTM A193-B8	ASTM A193-B16	ASTM A193-B16	ASTM A193-B16
GLAND NUT	ASTM A194-2H	ASTM A194-8	ASTM A194-4	ASTM A194-4	ASTM A194-4
BONNET THRUST RING	CARBON STEEL	ASTM A276-420	ANSI 4140	ANSI 4140	ANSI 4140
SUPPORTING COVER	ASTM A105	ASTM A276-420	AISI 4140	AISI 4140	ANSI 4140
NAME PLATE	STAINLESS STEEL	STAINLESS STEEL	STAINLESS STEEL	STAINLESS STEEL	STAINLESS STEEL

**Class 600**

Cast Carbon Steel Gate Valve

ASME B16.34,  
Pressure Seal, OS&Y, Rising Stem,  
Non-rising Handwheel,  
Flexible Wedge

Figure NO.:  
GPS6R, C00/NO.5  
GPS6B, C00/NO.5  
GPS6J, C00/NO.5

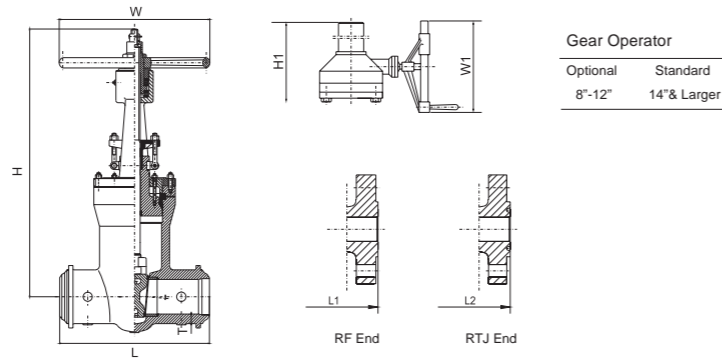

Gear Operator	
Optional	Standard
8"-12"	14"& Larger

NPS	in	2"	2-1/2"	3"	4"	5"	6"	8"	10"	12"	14"	16"	18"	20"	24"	26"	28"	30"
DN	mm	50	65	80	100	125	150	200	250	300	350	400	450	500	600	650	700	750
L-L1 (RF-BW)	in	11.5	13	14	17	20	22	26	31	33	35	39	43	47	55	57	61	65
	mm	292	330	356	432	508	559	660	787	838	889	991	1092	1194	1397	1448	1549	1651
L2(RTJ)	in	11.62	13.12	14.12	17.12	20.12	22.12	26.12	31.12	33.12	35.12	39.12	43.1	47.25	55.38	57.50	61.50	65.50
	mm	295	333	359	435	511	562	663	790	841	892	994	1095	1200	1407	1461	1562	1664
W	in	7.9	9.8	9.8	13.8	15.7	17.7	19.7	23.6	26.8	24	24	24	24	32	32	40	40
	mm	200	250	250	350	400	450	500	600	610	610	610	610	610	800	800	1000	1000
H	in	23.2	24.8	26.3	36	39.4	42.5	49.9	59.5	70.5	73.1	85.1	88.63	97.25	118.13	128	137.9	149
	mm	590	629	667	914	1000	1080	1267	1511	1791	1857	2162	2251	2470	3000	3251	3502	3785
WT(RF)	KG	47	55	60	110	208	250	412	730	960	1100	1500	-	-	-	-	-	-
WT(BW)	KG	24	42	48	84	150	210	336	605	818	980	1300	-	-	-	-	-	-

**Class 900**

Cast Carbon Steel Gate Valve

ASME B16.34,  
Pressure Seal, OS&Y, Rising Stem,  
Non-rising Handwheel,  
Flexible Wedge

Figure NO.:  
GPS9R, C00/NO.5  
GPS9B, C00/NO.5  
GPS9J, C00/NO.5

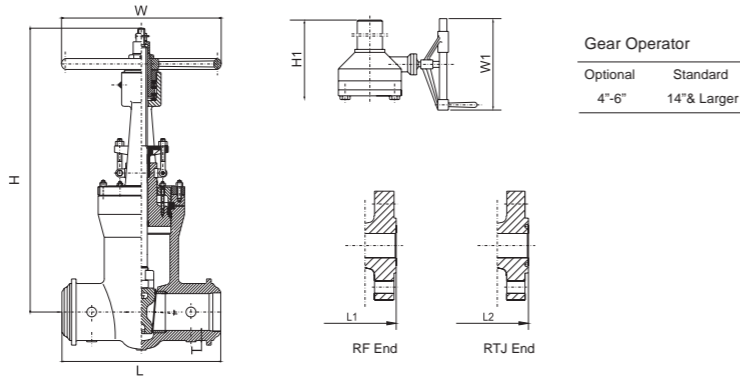

Gear Operator	
Optional	Standard
4"-6"	14"& Larger

NPS	in	2"	2-1/2"	3"	4"	6"	8"	10"	12"	14"	16"	18"	20"	24"	26"	28"	30"
DN	mm	50	65	80	100	150	200	250	300	350	400	450	500	600	650	700	750
L(BW)	in	8.5	10	12	14	20	26	31	36	39	43	48	52	61	64.5	68	71.5
	mm	216	254	305	356	508	660	787	914	991	1092	1219	1321	1549	1638	1727	1816
L1(RF)	in	14.5	16.5	15	18	24	29	33	38	40.5	44.5	48	52	61	-	-	-
	mm	368	419	381	457	610	737	838	965	1029	1130	1219	1321	1549	-	-	-
L2(RTJ)	in	14.62	16.62	15.12	18.12	24.12	29.12	33.12	38.12	40.88	44.88	48.5	52.5	61.75	-	-	-
	mm	371	422	384	460	613	740	841	968	1038	1140	1232	1333	1568	-	-	-
W	in	10	10	12	14	20	24	24	24	24	24	30.5	30.5	40	40	40	48
	mm	250	250	300	350	500	600	610	610	610	610	800	800	1000	1000	1000	1200
H	in	23	30	30	34	40	50	61	70	80	89	97.25	108.3	127.6	138.3	149	159.5
	mm	594	753	756	864	1013	1276	1543	1781	2026	2261	2470	2750	3242	3512	3785	4051
WT(RF)	KG	60	99	95	142	345	640	1020	1490	1785	2750	3380	4884	6500	-	-	-
WT(BW)	KG	40	67	70	106	268	520	850	1230	1880	2485	3000	3860	5665	-	-	-

**Class 1500**

Cast Carbon Steel Gate Valve

ASME B16.34,  
Pressure Seal, OS&Y, Rising Stem,  
Non-rising Handwheel,  
Flexible Wedge

Figure NO.:  
GPS15R, C00/NO.5  
GPS15B, C00/NO.5  
GPS15J, C00/NO.5

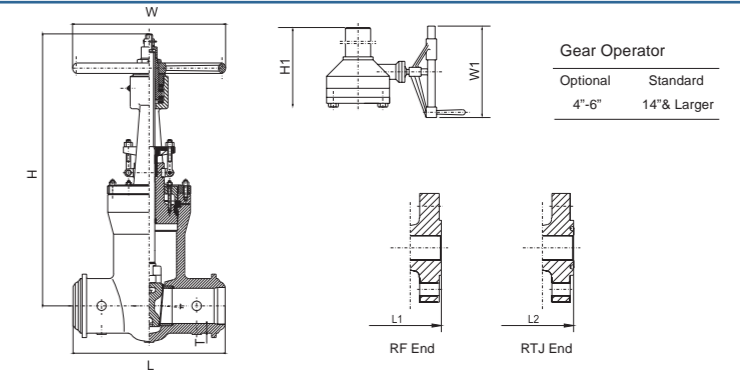

Gear Operator	
Optional	Standard
4"-6"	14"& Larger

NPS	in	2"	2-1/2"	3"	4"	6"	8"	10"	12"	14"	16"	18"	20"	24"
DN	mm	50	65	80	100	150	200	250	300	350	400	450	500	600
L(BW)	in	8.5	10	12	16	22	28	34	36	42	47	53	58	66
	mm	216	254	305	406	559	711	864	991	1067	1194	1346	1473	1676
L1(RF)	in	14.5	16.5	18.5	21.5	27.75	32.75	39	44.5	49.5	54.5	60.5	65.5	76.5
	mm	368	419	470	546	705	832	991	1130	1257	1384	1537	1664	1943
L2(RTJ)	in	14.62	16.62	18.62	21.62	28	33.13	39.38	45.12	50.25	55.38	61.38	66.38	77.63
	mm	371	422	473	549	711	842	1000	1146	1276	1407	1559	1686	1972
W	in	10	12	14	20	24	18	18	24	24	24	40	48	36
	mm	250	300	350	500	600	460	460	610	610	610	1000	1200	900
H	in	23	30	30	34	39	53	58.3	73.6	87	92	111.2	122.2	148.3
	mm	294	753	756	864	994	1349	1480	1870	2216	2331	2823	3102	3766
WT(RF)	KG	65	99	135	205	475	865	1530	2356	2696	4050	5184	6586	-
WT(BW)	KG	38	80	90	150	400	705	1160	1894	2360	3750	4300	5885	-

**Class 2500**

Cast Carbon Steel Gate Valve

ASME B16.34,  
Pressure Seal, OS&Y, Rising Stem,  
Non-rising Handwheel,  
Flexible Wedge

Figure NO.:  
GPS25R, C00/NO.5  
GPS25B, C00/NO.5  
GPS25J, C00/NO.5

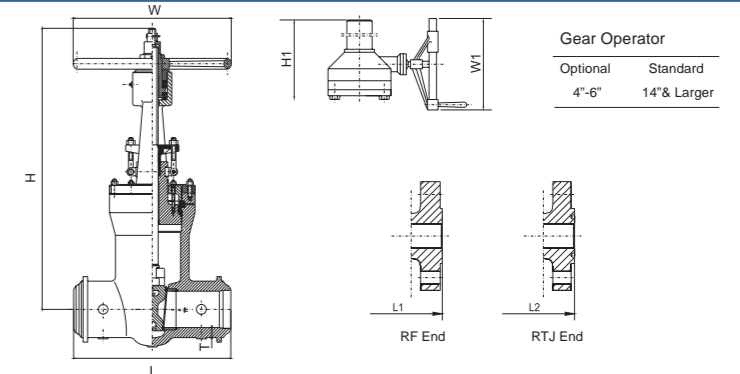

Gear Operator	
Optional	Standard
4"-6"	14"& Larger

NPS	in	2"	2-1/2"	3"	4"	6"	8"	10"	12"	14"	16"	18"	20"	24"
DN	mm	50	65	80	100	150	200	250	300	350	400	450	500	600
L(BW)	in	11	13	14.5	18	24	30	36	41	44	49	55	61	65.5
	mm	279	330	368	457	610	762	914	1041	1118	1245	1397	1549	1664
L1(RF)	in	17.75	20	22.75	26.5	36	40.25	60	56	-	-	-	-	-
	mm	451	508	578	673	914	1022	1270	1422	-	-	-	-	-
L2(RTJ)	in	17.88	20.25	23	26.88	36.5	40.88	50.88	56.88	-	-	-	-	-
	mm	454	514	584	683	927	1038	1292	1445	-	-	-	-	-
W	in	14	18	18	20	24	24	24	24	24	24	31.5	31.5	40
	mm	350	450	450	500	610	610	610	610	610	610	800	800	1000
H	in	23	30	30	34	44	55	69	74	94.13	97.25	116.2	128.8	153.7
	mm	594	753	756	870	1129	1389	1748	1873	2291	2470	2950	3270	3902
WT(RF)	KG	75	98	120	220	631	1046	2205	3495	-	-	-	-	-
WT(BW)	KG	70	80	85	295	492	850	1815	2400	3360	4310	-	-	-

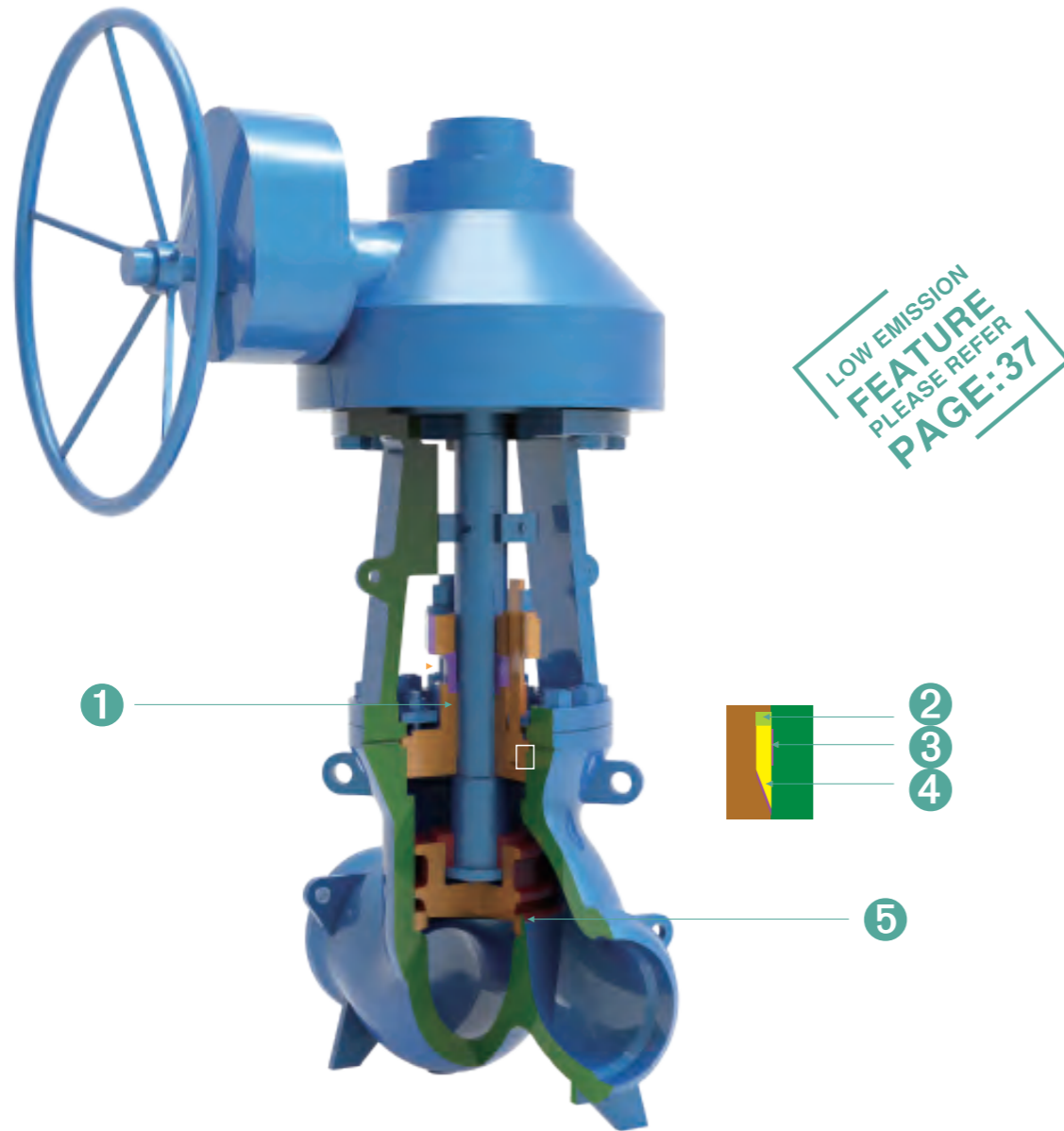

- 1 Separated rings absorb the thrust along the stem applied by the internal pressure.
- 2 Sealing rings are used to withstand pressure and prevent deformation of the gaskets.
- 3 Stainless steel inlay to ensure soundness and corrosion-resistance in the critical body sealing zone for carbon and alloy steel valves.
- 4 Mild steel gasket seal to provide large contact area for perfect sealing.
- 5 Seat ring with stellite 6 overlay is standard design and installed with seal weld.

Part	Standard	Stainless Steel	High Temperature Service		
			ASTM A217-WC6/STL. OVERLAY	ASTM A217-WC9/STL. OVERLAY	ASTM A217-C12A/STL. OVERLAY
BODY	ASTM A216-WCB/STL. OVERLAY	ASTM A351-CF8M/STL. OVERLAY	ASTM A217-WC6/STL. OVERLAY	ASTM A217-WC9/STL. OVERLAY	ASTM A217-C12A/STL. OVERLAY
BONNET	ASTM A105	ASTM A182-F316	ASTM A182-F11	ASTM A182-F22	ASTM A217-C12A
DISC	ASTM A182-F6a & ASTM A105/ER410	ASTM A182-F316	ASTM A182-F6a & ASTM A182-F11/ER410	ASTM A182-F6a & ASTM A182-F22/ER410	ASTM A182-F6a
STEM NUT	ASTM A439 D-2 or BRONZE	ASTM A439 D-2 or BRONZE	ASTM A439 D-2 or BRONZE	ASTM A439 D-2 or BRONZE	ASTM A439 D-2 or BRONZE
GLAND FLANGE	ASTM A105N	ASTM A182 F316	ASTM A182 F11	ASTM A182 F11	ASTM A182 F11
HANDWHEEL	DUCTILE IRON	DUCTILE IRON	DUCTILE IRON	DUCTILE IRON	DUCTILE IRON
BONNET SEAL RING	GRAPHITE	GRAPHITE	GRAPHITE	GRAPHITE	GRAPHITE
STEM	ASTM A182-F6a	ASTM A182-F316	ASTM A182-F6a	ASTM A182-F6a	ASTM A182-F6a
RETAINING NUT FOR STEM NUT	CARBON STEEL	STAINLESS STEEL	CARBON STEEL	CARBON STEEL	CARBON STEEL
GLAND	ASTM A276-420	ASTM A182-316	ASTM A276-420	ASTM A276-420	ASTM A276-420
HANDWHEEL NUT	CARBON STEEL	CARBON STEEL	CARBON STEEL	CARBON STEEL	CARBON STEEL
DISC NUT	ASTM A276-420	ASTM A182-316	ASTM A276-420	ASTM A276-420	ASTM A276-420
STEAM WASHER	ASTM A276-430	N/A	ASTM A276-430	ASTM A276-430	ASTM A276-430
THRUST RING	CARBON STEEL	ASTM A276-420	ANSI 4140	ANSI 4140	ANSI 4140
PACKING	GRAPHITE+SS	GRAPHITE+SS	GRAPHITE+SS	GRAPHITE+SS	GRAPHITE+SS
CLIPPING RING	ASTM A216-WCB	ASTM A351-CF8	ASTM A217-WC6	ASTM A217-WC6	ASTM A276-420
YOKE STUD	ASTM A193-B7	ASTM A193-B8	ASTM A193-B16	ASTM A193-B16	ASTM A193-B16
YOKE NUT	ASTM A194-2H	ASTM A194-8	ASTM A194-4	ASTM A194-4	ASTM A194-4
GLAND EYE BOLT	ASTM A193-B7	ASTM A193-B8	ASTM A193-B16	ASTM A193-B16	ASTM A193-B16
GLAND NUT	ASTM A194-2H	ASTM A194-8	ASTM A194-4	ASTM A194-4	ASTM A194-4
ORIENTED BLOCK	CARBON STEEL	ASTM A276-420	CARBON STEEL	CARBON STEEL	CARBON STEEL
YOKE	ASTM A216-WCB	ASTM A351-CF8	ASTM A216-WCB & ASTM A217-WC6	ASTM A216-WCB & ASTM A217-WC6	ASTM A217-C12A
NAME PLATE	STAINLESS STEEL	STAINLESS STEEL	STAINLESS STEEL	STAINLESS STEEL	STAINLESS STEEL



**Class 600**

Cast Carbon Steel Globe Valve

ASME B16.34,  
Pressure Seal, OS&Y,  
Rising Stem and Handwheel,  
Swivel Disc

Figure NO.:  
GLP6R, C00/NO.5  
GLP6B, C00/NO.5  
GLP6J, C00/NO.5

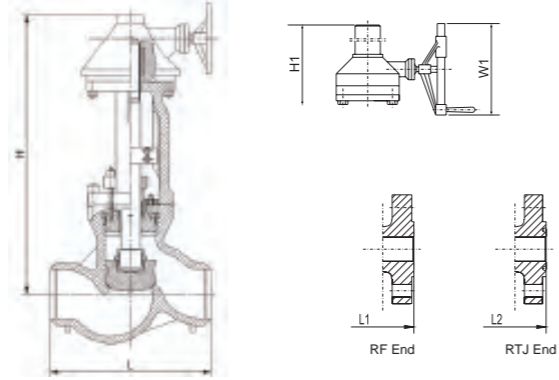

Gear Operator	
Optional	Standard
8"-10"	12"& Larger

NPS	in	2"	2-1/2"	3"	4"	5"	6"	8"	10"	12"	14"	16"	18"	20"	24"
DN	mm	50	65	80	100	125	150	200	250	300	350	400	450	500	600
L-L1 (RF-BW)	in	11.5	13	14	17	20	22	26	31	33	35	39	43	47	55
	mm	292	330	356	432	508	559	660	787	838	889	991	1092	1194	1397
L2(RTJ)	in	11.62	13.12	14.12	17.12	20.12	22.12	26.12	31.12	33.12	35.12	39.12	43.12	47.25	55.38
	mm	295	333	359	435	511	562	663	790	841	892	994	1095	1200	1407
W	in	9.8	11.8	13.8	17.7	19.7	22	23.6	27.6	24	24	30	-	-	-
	mm	250	300	350	450	500	560	600	700	610	610	760	-	-	-
H	in	21.7	24.8	26.8	29.5	39.4	45.3	49.2	55.1	61	70.9	85	-	-	-
	mm	550	630	680	750	1000	1150	1250	1400	1550	1800	2160	-	-	-
WT(RF)	KG	46	55	79	99	190	336	620	-	-	-	-	-	-	-
WT(BW)	KG	28	42	46	76	150	320	540	-	-	-	-	-	-	-

**Class 900**

Cast Carbon Steel Globe Valve

ASME B16.34,  
Pressure Seal, OS&Y,  
Rising Stem and Handwheel,  
Swivel Disc

Figure NO.:  
GLP9R, C00/NO.5  
GLP9B, C00/NO.5  
GLP9J, C00/NO.5

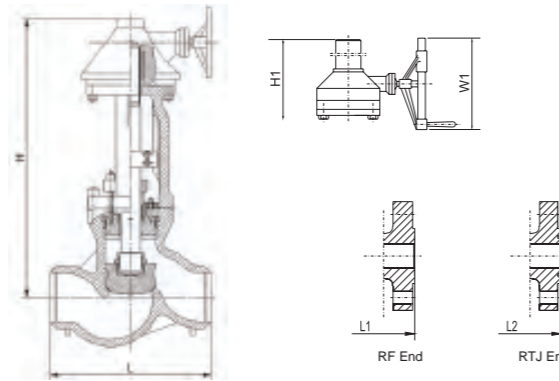

Gear Operator	
Optional	Standard
4"-10"	8"& Larger

NPS	in	2"	2-1/2"	3"	4"	6"	8"	10"	12"	14"	16"	18"	20"	24"
DN	mm	50	65	80	100	150	200	250	300	350	400	450	500	600
L(BW)	in	8.5	10	12	14	20	26	31	36	39	43	-	-	-
	mm	216	254	305	356	508	660	787	914	991	1092	-	-	-
L1(RF)	in	14.5	16.5	15	18	24	29	33	38	40.5	44.5	48	52	61
	mm	368	419	381	457	610	737	838	965	1029	1130	1219	1321	1549
L2(RTJ)	in	14.62	16.62	15.12	18.12	24.12	29.12	33.13	38.13	40.88	44.88	48.5	52.5	61.75
	mm	371	422	384	460	613	740	841	968	1038	1140	1232	1334	1568
W	in	14	14	18	20	24	24	24	40	40	48	-	-	-
	mm	350	350	450	500	610	610	610	1000	1000	1200	-	-	-
H	in	24.4	25.2	28.4	33.5	48.2	53.1	61	68.9	78.8	91	-	-	-
	mm	619	641	721	850	1225	1350	1550	1750	2000	2310	-	-	-
WT(RF)	KG	96	110	120	165	330	934	1285	1747	2500	2633	-	-	-
WT(BW)	KG	53	74	90	145	330	819	1120	1625	2300	2520	-	-	-

**Class 1500**

Cast Carbon Steel Globe Valve

ASME B16.34,  
Pressure Seal, OS&Y,  
Rising Stem and Handwheel,  
Swivel Disc

Figure NO.:  
GLP15R, C00/NO.5  
GLP15B, C00/NO.5  
GLP15J, C00/NO.5

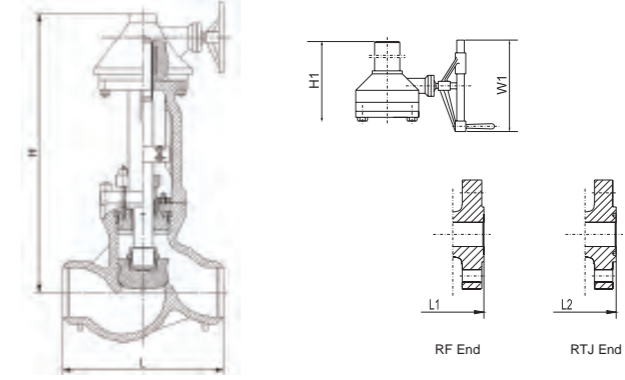

Gear Operator	
Optional	Standard
2"-3"	4"& Larger

NPS	in	2"	2-1/2"	3"	4"	6"	8"	10"	12"	14"	16"	18"	20"	24"
DN	mm	50	65	80	100	150	200	250	300	350	400	450	500	600
L(BW)	in	8.5	10	12	16	22	28	34	39	42	47	-	-	-
	mm	216	254	305	406	559	711	864	991	1067	1194	-	-	-
L1(RF)	in	14.5	16.5	18.5	21.5	27.75	32.75	39	44.5	49.5	54.5	60.5	65.5	76.5
	mm	368	419	470	546	705	832	991	1130	1257	1384	1537	1664	1943
L2(RTJ)	in	14.62	16.62	18.62	21.62	28	33.13	39.38	45.13	50.25	55.38	61.38	66.38	77.62
	mm	371	422	473	549	711	842	1000	1146	1276	1406	1559	1686	1971
W	in	14	14	20	22	24	24	40	40	48	-	-	-	-
	mm	350	350	500	560	610	610	1000	1000	1200	-	-	-	-
H	in	24.4	25.2	32.9	33.7	48.4	70.9	78.8	91	106	-	-	-	-
	mm	619	641	835	857	1230	1800	2000	2311	2692	-	-	-	-
WT(RF)	KG	84	116	184	303	825	1189	1936	3400	-	-	-	-	-
WT(BW)	KG	54	97	152	285	680	1008	1624	2830	-	-	-	-	-

**Class 2500**

Cast Carbon Steel Globe Valve

ASME B16.34,  
Pressure Seal, OS&Y,  
Rising Stem and Handwheel,  
Swivel Disc

Figure NO.:  
GLP25R, C00/NO.5  
GLP25B, C00/NO.5  
GLP25J, C00/NO.5

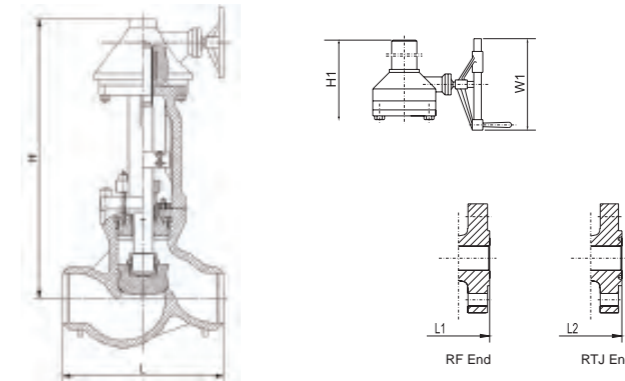

Gear Operator	
Optional	Standard
2"	3"& Larger

NPS	in	2"	2-1/2"	3"	4"	6"	8"	10"	12"	14"
DN	mm	50	65	80	100	150	200	250	300	350
L(BW)	in	11	13	14.5	18	24	30	36	41	41
	mm	279	330	368	457	610	762	914	1041	1041
L1(RF)	in	17.75	20	22.75	26.5	36	40.25	50	56	-
	mm	451	508	578	673	914	1022	1270	1422	-
L2(RTJ)	in	17.88	20.25	23	26.88	36.5	40.88	50.88	56.88	-
	mm	454	514	584	683	927	1038	1292	1445	-
W	in	16	20	22	24	24	24	40	40	-
	mm	400	500	560	610	610	610	1000	1000	-
H	in	24.3	30.7	31.5	51.2	53.9	85	100	106	-
	mm	616	781	800	1300	1370	2160	2540	2692	-
WT(RF)	KG	115	132	189	384	1071	2063	-	-	-
WT(BW)	KG	92	115	154	340	960	1905	-	-	-

LOW EMISSION  
FEATURE  
PLEASE REFER  
PAGE:37

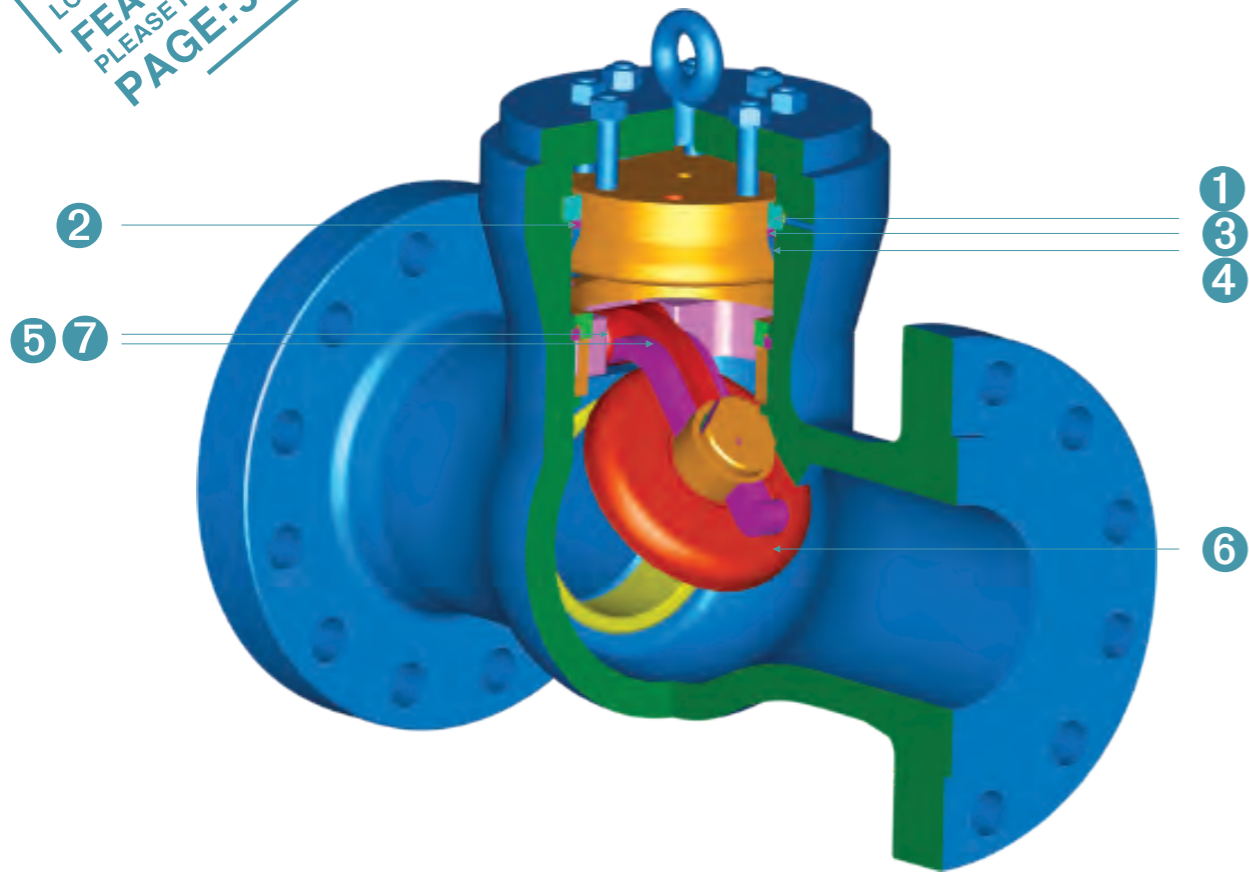

- 1 Separated rings absorb the thrust along the stem applied by the internal pressure.
- 2 Sealing rings are used to withstand pressure and prevent deformation of the gaskets.
- 3 Mild steel gasket seal to provide a large seal contact area for perfect sealing.
- 4 Stainless steel inlay to ensure soundness and corrosion-resistance in the critical body sealing zone for carbon and alloy steel valves.
- 5 Hinge pin design ensuring no pressure boundary intrusion.
- 6 Standard swing disc type to be used in horizontal position for liquid service applications or used in vertical position where liquid flow from botton to top.
- 7 Hinge and hinge pin design to permit full movement of the disc.

Part	Standard	Stainless Steel	High Temperature Service		
			ASTM A217-WC6	ASTM A217-WC9	ASTM A217-C12A
BODY	ASTM A216-WCB	ASTM A351-CF8M	ASTM A217-WC6	ASTM A217-WC9	ASTM A217-C12A
COVER	ASTM A216-WCB ASTM A 105 (4"&Smaller )	ASTM A351-CF8M ASTM A 182-F316 (4"&Smaller )	ASTM A217-WC6 ASTM A 182-F11 (4"&Smaller )	ASTM A217-WC9 ASTM A 182-F22 (4"&Smaller )	ASTM A217-C12A ASTM A 182-F91 (4"&Smaller )
DISC	ASTM A217-CA15 & ASTM A216-WCB/ ER410	ASTM A351-CF8M/STL. OVERLAY	ASTM A217-CA15 & ASTM A217-WC6/ ER410	ASTM A217-CA15 & ASTM A217-WC9/ ER410	ASTM A217-CA15
HINGE	ASTM A105	ASTM A351-CF8M	ASTM A217-WC6	ASTM A217-WC9	ASTM A217-C12A
HINGE PIN	ASTM A182-F6a	ASTM A276-316	ASTM A182-F6a	ASTM A182-F6a	ASTM A182-F6a
DISC NUT	ASTM A276-420	ASTM A276-316	ASTM A276-420	ASTM A276-420	ASTM A276-420
BONNET SEAL RING	GRAPHITE	GRAPHITE	GRAPHITE	GRAPHITE	GRAPHITE
HOOK SCREW	CARBON STEEL	STAINLESS STEEL	CARBON STEEL	CARBON STEEL	CARBON STEEL
COVER STUD	ASTM A193-B7	ASTM A193-B8	ASTM A193-B16	ASTM A193-B16	ASTM A193-B16
COVER NUT	ASTM A194-2H	ASTM A194-8	ASTM A194-4	ASTM A194-4	ASTM A194-4
SEAT RING	ASTM A105/STL. OVERLAY	ASTM A182-F316/STL. OVERLAY	ASTM A182-F11/STL. OVERLAY	ASTM A182-F22/STL. OVERLAY	ASTM A182-F6a/STL. OVERLAY
SEPARATE RING COVER	CARBON STEEL	ASTM A276-420	ANSI 4140	ANSI 4140	ANSI 4140
THRUST RING COVER	CARBON STEEL	ASTM A276-420	ANSI 4140	ANSI 4140	ANSI 4140
SUPPORTING COVER	ASTM A105	ASTM A276-420	ANSI 4140	ANSI 4140	ANSI 4140
STOP RING	ASTM A276-420	ASTM A276-316	ASTM A276-420	ASTM A276-420	ASTM A276-420
YOKE	ASTM A216-WCB	ASTM A276-316	ASTM A216-WCB& ASTM A217-WC6	ASTM A216-WCB& ASTM A217-WC6	ASTM A217-C12A
SEPARATE RING FOR STOP RING	ASTM A276-420	ASTM A276-316	ASTM A276-420	ASTM A276-420	ASTM A276-420
SPLIT PIN	STAINLESS STEEL	STAINLESS STEEL	STAINLESS STEEL	STAINLESS STEEL	STAINLESS STEEL
STOP RING SCREW	STAINLESS STEEL	STAINLESS STEEL	STAINLESS STEEL	STAINLESS STEEL	STAINLESS STEEL
NAME PLATE	STAINLESS STEEL	STAINLESS STEEL	STAINLESS STEEL	STAINLESS STEEL	STAINLESS STEEL

**Class 600**

Cast Carbon Steel Check Valve

ASME B16.34,  
Pressure Seal Swing Disc Type

Figure NO.:  
SPS6R, C00/NO.5  
SPS6B, C00/NO.5  
SPS6J, C00/NO.5

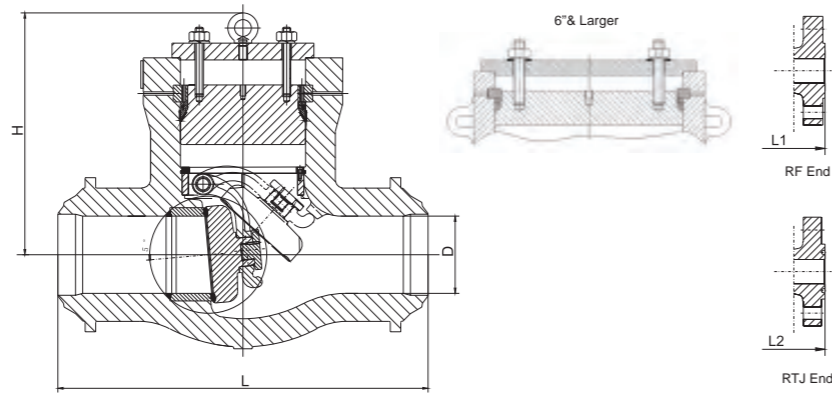

NPS	in	2"	2-1/2"	3"	4"	5"	6"	8"	10"	12"	14"	16"	18"	20"	24"	26"	28"	30"
DN	mm	50	65	80	100	125	150	200	250	300	350	400	450	500	600	650	700	750
L (RF-BW)	in	11.5	13	14	17	20	22	26	31	33	35	39	43	47	55	57	63	65
	mm	292	330	356	432	508	559	660	787	838	889	991	1092	1194	1397	1448	1600	1651
L2(RTJ)	in	11.62	13.12	14.12	17.12	20.12	22.12	26.12	31.12	33.12	35.12	39.12	43.13	47.25	55.38	57.5	63.5	65.5
	mm	295	333	359	435	511	562	663	790	841	892	994	1095	1200	1407	1461	1613	1664
H	in	9.5	10.4	10.6	12.5	15.7	15.7	23.1	23.9	27.4	29.5	28.7	28.8	32.3	37.4	39.38	43.25	47.25
	mm	241	264	270	318	400	400	587	606	695	749	730	730	819	949	1000	1099	1200
WT(RF)	KG	31	50	61	85	135	190	350	500	682	880	1150	-	-	4046	3100	3500	4000
WT(BW)	KG	25	42	49	76	85	130	260	370	568	660	850	-	-	3556	2500	2800	3150

**Class 900**

Cast Carbon Steel Check Valve

ASME B16.34,  
Pressure Seal Swing Disc Type

Figure NO.:  
SPS9R, C00/NO.5  
SPS9B, C00/NO.5  
SPS9J, C00/NO.5

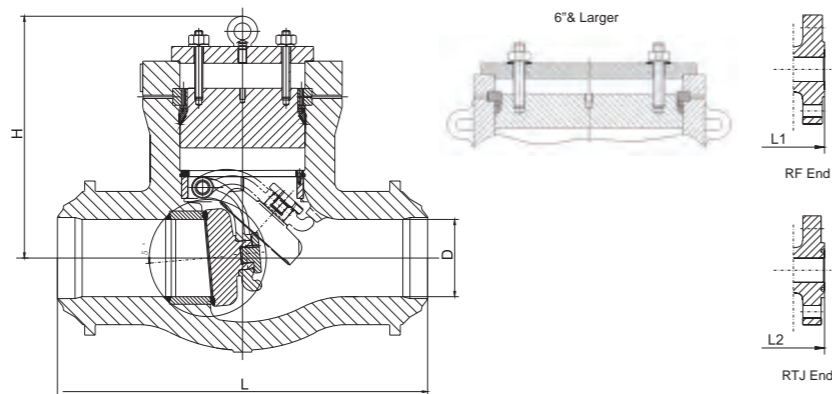

NPS	in	2"	2-1/2"	3"	4"	6"	8"	10"	12"	14"	16"	18"	20"	24"
DN	mm	50	65	80	100	150	200	250	300	350	400	450	500	600
L(BW)	in	8.5	10	12	14	20	26	31	36	39	43	43	43	52
	mm	216	254	305	356	508	660	787	914	991	1092	1092	1092	1321
L1(RF)	in	14.5	16.5	15	18	24	29	33	38	40.5	44.5	48	52	61
	mm	368	419	381	457	610	737	838	965	1029	1130	1219	1321	1549
L2(RTJ)	in	14.6	16.1	15.1	18.1	24.1	29.1	33.1	38.1	40.9	44.9	48.5	52.5	61.75
	mm	371	422	384	460	613	740	841	968	1038	1140	1232	1333	1568
H	in	9.5	10.4	10.6	12.5	15.7	23.1	23.9	27.4	29.5	28.7	33.5	34	37.8
	mm	241	264	270	318	400	587	606	695	749	730	851	864	959
WT(RF)	KG	42	55	61	110	250	450	825	995	1628	1733	2300	-	-
WT(BW)	KG	22	32	45	75	148	312	725	875	1281	1418	1850	-	-

**Class 1500**

Cast Carbon Steel Check Valve

ASME B16.34,  
Pressure Seal Swing Disc Type

Figure NO.:  
SPS15R, C00/NO.5  
SPS15B, C00/NO.5  
SPS15J, C00/NO.5

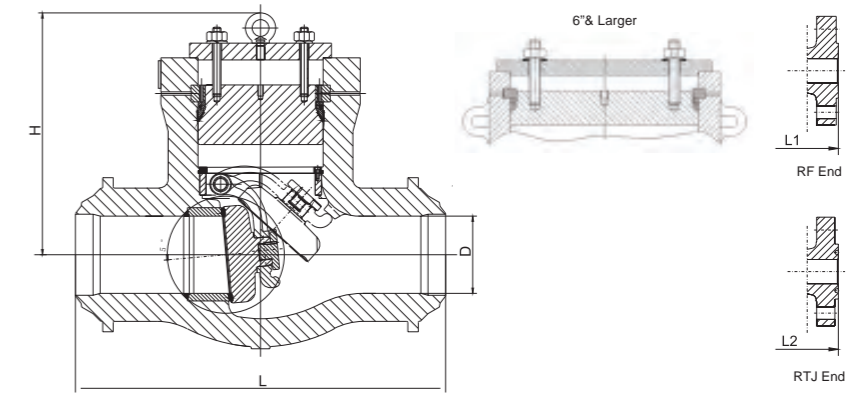

NPS	in	2"	2-1/2"	3"	4"	6"	8"	10"	12"	14"	16"	18"	20"	24"
DN	mm	50	65	80	100	150	200	250	300	350	400	450	500	600
L(BW)	in	8.5	10	12	16	22	28	34	39	42	47	47	47	76.5
	mm	216	254	305	406	559	711	864	991	1067	1194	1194	1194	1943
L1(RF)	in	14.5	16.5	18.5	21.5	27.8	32.8	39	44.5	49.5	54.4	60.5	65.5	76.5
	mm	368	419	470	546	705	732	991	1130	1257	1384	1537	1664	1943
L2(RTJ)	in	14.6	16.6	18.6	21.6	28	33.1	39.4	45.1	50.3	55.4	61.38	66.38	77.63
	mm	371	422	473	549	711	842	1000	1146	1276	1407	1559	1686	1972
H	in	9.5	10.4	10.8	12.5	16.6	18.9	23.3	25.4	28	29.5	34.63	37.38	43.25
	mm	241	264	274	318	422	479	591	645	711	749	880	949	1099
WT(RF)	KG	30	58	62	113	345	551	858	1628	1811	2539	3306	-	-
WT(BW)	KG	20	34	50	94	270	454	695	1155	1475	2110	3266	-	-

**Class 2500**

Cast Carbon Steel Check Valve

ASME B16.34,  
Pressure Seal Swing Disc Type

Figure NO.:  
SPS25R, C00/NO.5  
SPS25B, C00/NO.5  
SPS25J, C00/NO.5

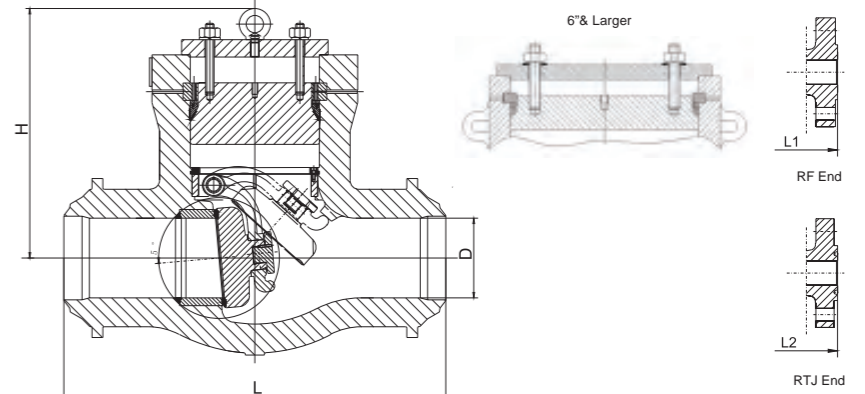

NPS	in	2"	2-1/2"	3"	4"	6"	8"	10"	12"	14"	16"	18"	20"	24"
DN	mm	50	65	80	100	150	200	250	300	350	400	450	500	600
L(BW)	in	11	13	14.5	18	24	30	36	41	41	41	49	50	60
	mm	279	330	368	457	610	762	914	1041	1041	1041	1245	1270	1525
L1(RF)	in	17.8	20	22.8	26.5	36	40.3	50	56	-	-	-	-	-
	mm	451	508	578	673	914	1022	1270	1422	-	-	-	-	-
L2(RTJ)	in	17.9	20.3	23	26.9	36.5	40.9	50.9	56.9	60.88	-	-	-	-
	mm	454	514	584	683	927	1038	1292	1445	1546	-	-	-	-
H	in	9.6	10.4	10.6	12.5	17.8	22	22.7	25.8	33.88	-	-	-	-
	mm	245	264	270	318	451	559	576	656	860	-	-	-	-
WT(RF)	KG	74	124	156	299	437	736	1718	2700	3350	-	-	-	-
WT(BW)	KG	30	74	89	142	298	540	820	1480	2450	-	-	-	-

**BA Series for Gate & Globe Valves**

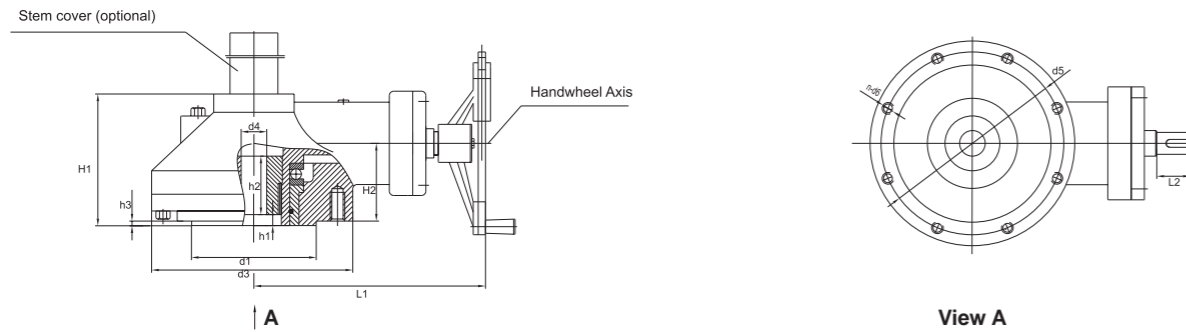

**BA-Y Series for Globe Valves**

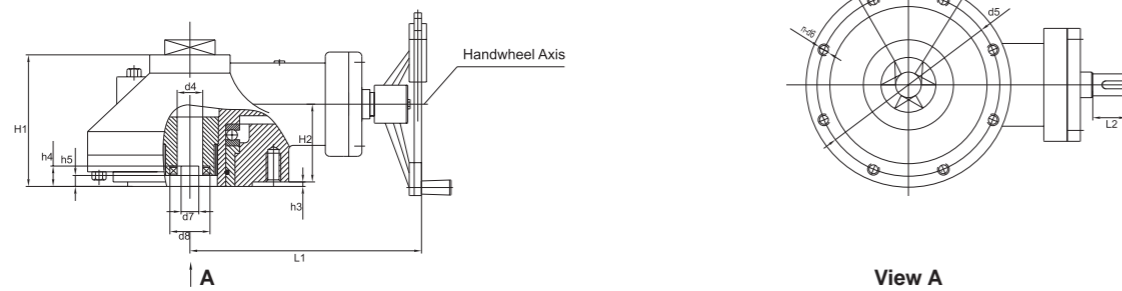

**1.Main Material:**

Name of parts	Housing	Bevel gear	Output shaft	Stem nut
Material	Carbon steel & Cast iron	AISI 1045 & 5140	AISI 1045	ASTM A439-D2 & QAI9-4

**2.Technical Parameters:**

Item	Type								
	BA000	BA00	BA0	BA1	BA2	BA3	BA4	BA5	BA6
Allowable torque(N.m)	200	400	750	1500	3000	6000(9000)	10000(15000)	22100	32000
Allowable thrust(KN)	40	100	150	200	350	840	1400	2400	2745
Reduction ratio	4:1	3:1	3:1	4:1:1	6:1	58:1(86:1)	86:1(104:1)	104:1(128:1)	125:1
Allowable stem diameter(mm)	25	42	55	62	75	115	125	125	150
Handwheel diameter(mm)	305	305	305	460	610	810	1000	1200	1200

Note: The allowable torque and the ratio parameter in the brackets will be selected by the manufacturer.

**3.Flange Type and Dimensions (mm)**

Code Type	L1	L2	H1	H2	d1	d2	d3	d4(max)	d5	n-d6	d7	d8	h1	h2	h3	h4	h5	Flange type
BA000	200	45	100	59	70(f8)		146	25	102	4-M10	40	51	1	42	3	8	4	F10
BA00	210	60	122	76	100(f8)		178	42	140	4-M16	50	64.5	1	60	4	10	5	F14
BA0	232	60	135	84	130(f8)		210	55	165	4-M20	63	79	1	70	5	15	5	F16
BA1	283	60	160	95	200(f8)		289	62	254	8-M16	70	89	1	75	5	15	5	F25
BA2	370	60	220	140	230(f8)		346	75	298	8-M20	95	119	15	110	5	18	5	F30
BA3	610	60	330	328	260(f8)	428	510	115	356	8-M30	128	166	30	168	5	18	5	F35
BA4	668	110	360	410	300(f8)	475	620	125	406	8-M36	138	188	35	180	8	25	5	F40
BA5	668	110	360	410	370	544	690	125	483	12-M36	150	210	35	180	8	32	5	F48
BA6	1020	60	500	282	470	686	810	150	603	20-M36	178	240	40	230	8	40	5	F48

With the enhancement of people ecological awareness since 1960's, especially under the backround of nowadays quick economic globalization, protecting environment is becoming common understanding in present global development, whether developed or developing countries, and had led to born associated law and regulation in different fields, including modern process industries.

Industrial valves are one of main pollution sources in modern process industries because of fugitive emission. To minimize the risk of process media leaked through valves to human health, safety and environment, Neway developed low emission technology for all series valves, which featured the essential function of controlling effectively the fugitive emission leakage of various media from valves in virtue of emission defense material using and special structure design, and these valves are measured and tested in accordance with ISO 15848 or Shell SPE 77/312.



**Design Features**

**Low Emission Packing**

Neway actively works with reputable and industry leading sealing solution companies to create low emission solutions that can cover valves from cryogenic to extreme high temperature in variety of endurance range down to 10ppm without usage of bellow seal.



**Stuffing box and stem finish**

All surface finish for Neway valve's stem and stuffing boxes are tightly controlled to achieve optimized surface finish for the designated sealing solution.

**Optional live-loaded eye bolt**

Live-loaded eye bolt is optional on customer request. The special structure can maintain a permanent packing stress in virtue of a set of belleville spring, and extend the low emission service life. Neway standard Belleville springs are protected by a weatherproof cap to keep them from environmental contamination so as to ensure a long and continual stable work life.

**Fugitive Emission Valve Test**

Neway full series low emission gate, globe and check valves in addition to type testing. Neway offers production testing capabilities to ISO 15848-2, Shell MESC 77/312 or other customized testing standards. The table below presents typical test parameters.

Test Standard	ISO 15848	Neway Acceptable Level	
		Test Medium	Test Pressure
Test Medium	97% Helium	Stem Seal Leakage Rate	SO 15848 class B 1.78x10 <sup>-7</sup> Pa.m <sup>3</sup> /s (Per mm Stem diameter)
Test Pressure	Valve body pressure equals to the one specified in ASME B16.34 at selected temperature	Mechanical Cycles	100
Test Equipment	Helium Spectrometer	Temperature	-196 ~ 450°C

For servicing H S-containing environments in oil and gas production, Neway offers NACE valve made of the component metal materials specially heat-treated and hardness-controlled in compliance with NACE standard Mr0175 or 0103, so as to resist all mechanisms of cracking that can be caused by H S, including sulfide stress cracking (SSC), stress corrosion cracking (SCC), and other hydrogen-induced cracking. Below table show typical Nace material configuration for Neway cast steel gate valves:

## NACE Valves Compared to API 600 Valves

Valve Parts	ASTM Specification	API 600 Valves	Nace Valves
Body/Bonnet	A216 Gr. WCB	≤ 22HRC	≤ 22HRC
Wedge	A216 Gr. WCB or A217 CA15	Quenching + High Temperature Tempering 25-30HRC	Quenching + Double Tempering ≤ 22HRC
Seating Ring	A105 + Stellite 6 Overlayed	Stress Relieving Tempering Overlay hardness ≥ 38HRC	Stress Relieving Tempering Overlay hardness ≥ 38HRC
Stem	A182 F6a	Quenching + High Temperature Tempering 17-22HRC	Quenching + Double Tempering ≤ 22HRC
Gland	ANSI 420	Quenching + High Temperature Tempering 31-35HRC	Quenching + Double Tempering ≤ 22HRC
Backseat Bushing	ANSI 420	Quenching + High Temperature Tempering 31-35HRC	Quenching + Double Tempering ≤ 22HRC
Body/Bonnet Studs		ASTM A193 Grade B7	ASTM A193 Grade B7M
Body/Bonnet Nuts		ASTM A194 Grade 2H	ASTM A194 Grade 2HM

## Special Design Feature

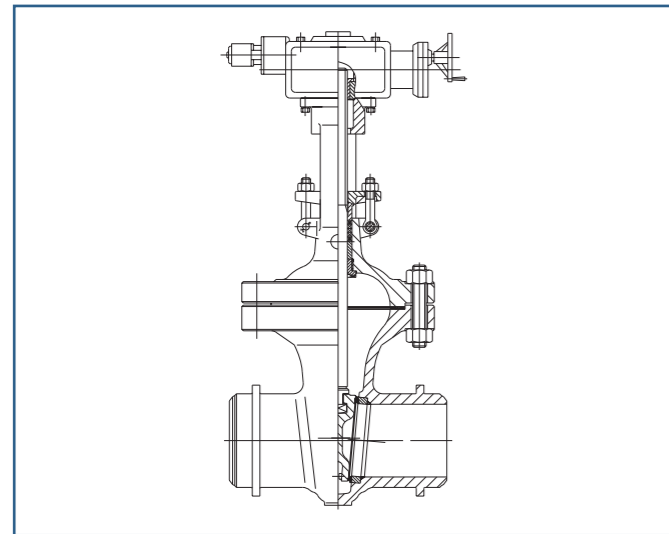

All gate and globe valves can be equipped with electric, Pneumatic or hydraulic actuator, per customer's specification.

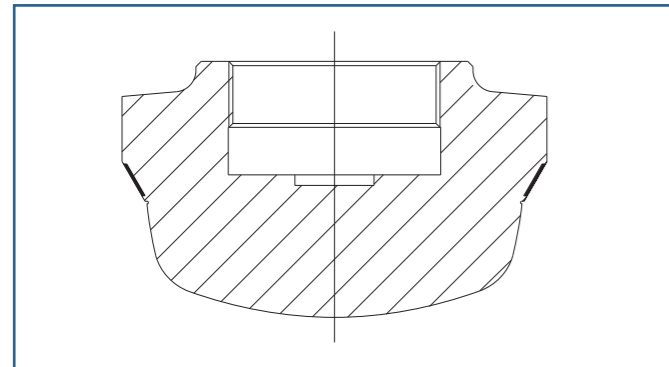

Parabola disc

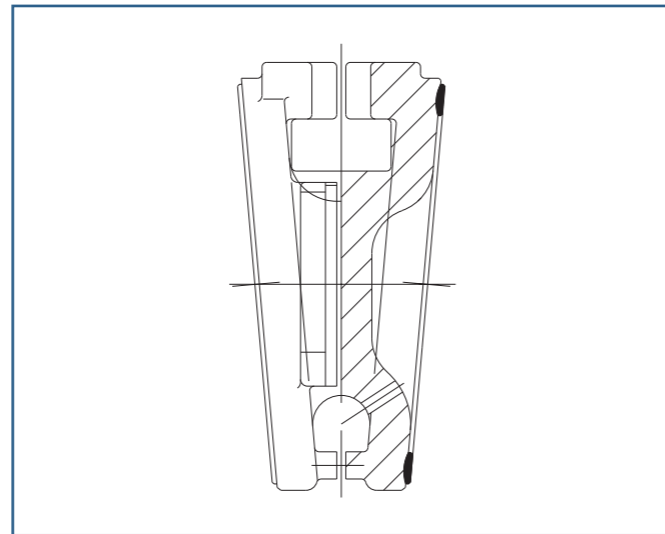

Pressure relief hole

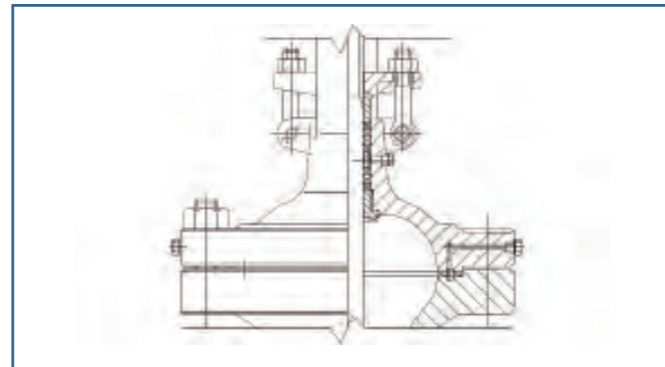

Double sealing gasket and packing with intermediate leak detection

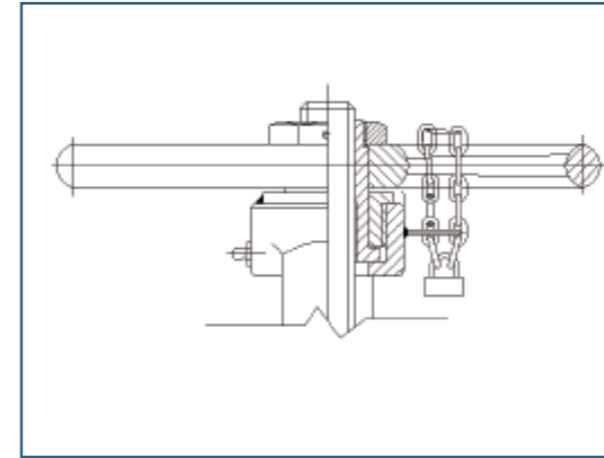

Locking device on the handwheel

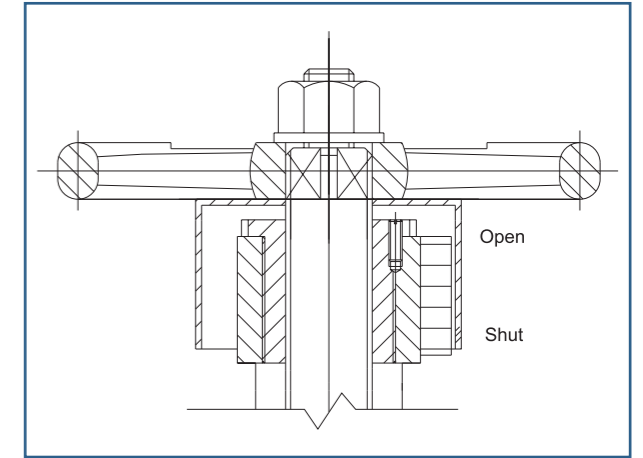

Position indicator on globe valves

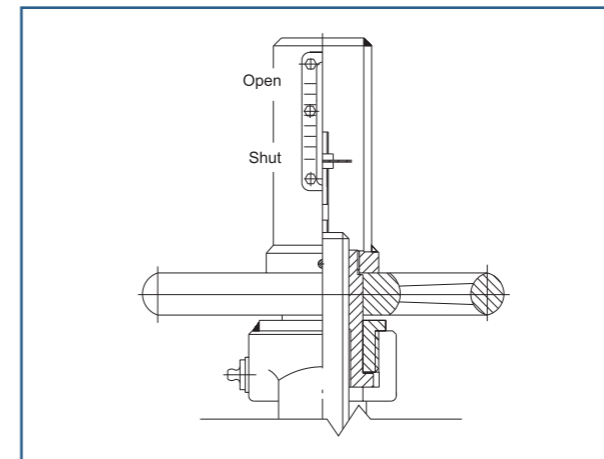

Position indicator on gate valves

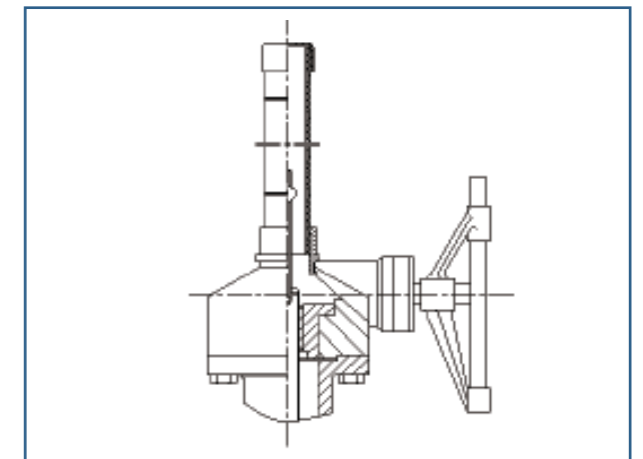

Position indicator on gear box

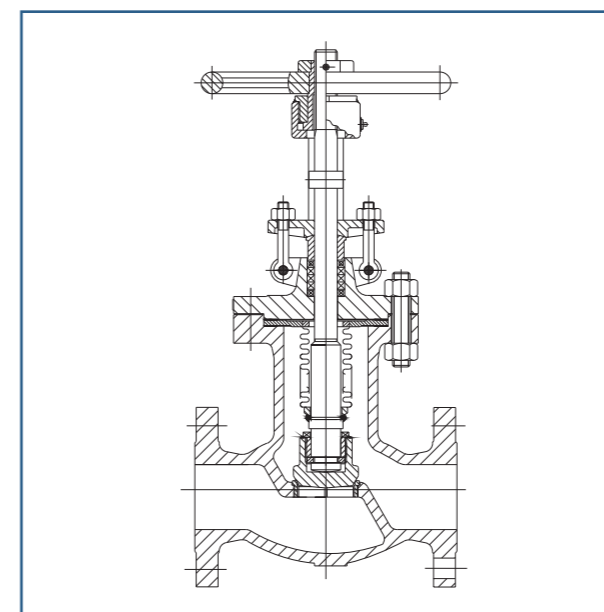

Casting steel bellows sealed valves

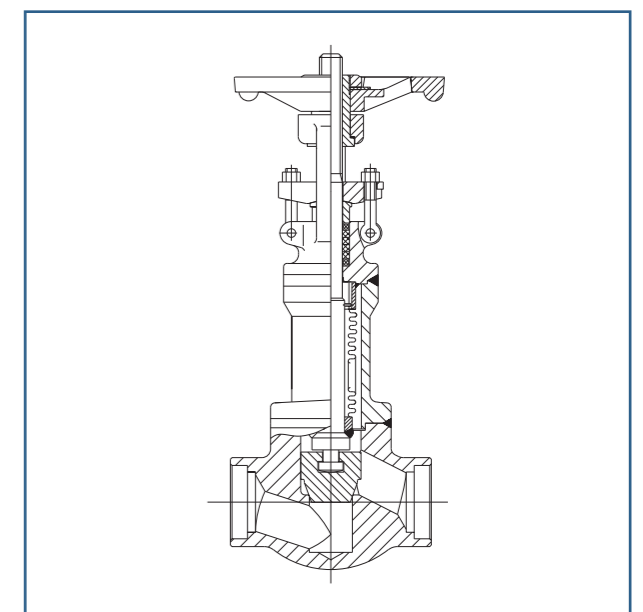

Forging steel bellows sealed valves

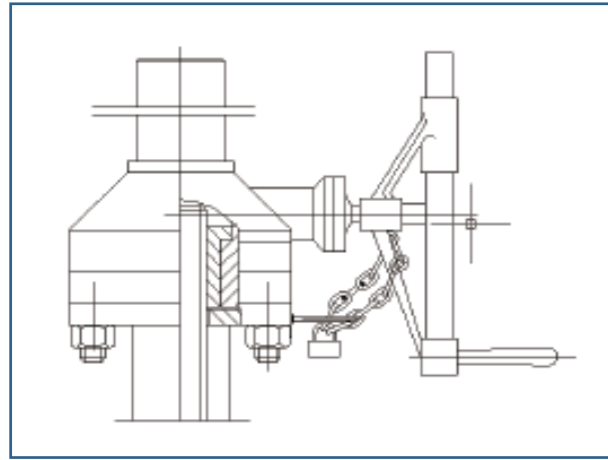

Locking device on the gear box

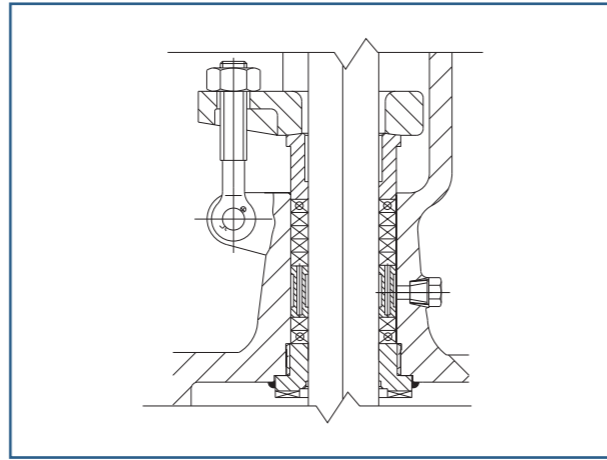

The lantern on the gate and globe valves

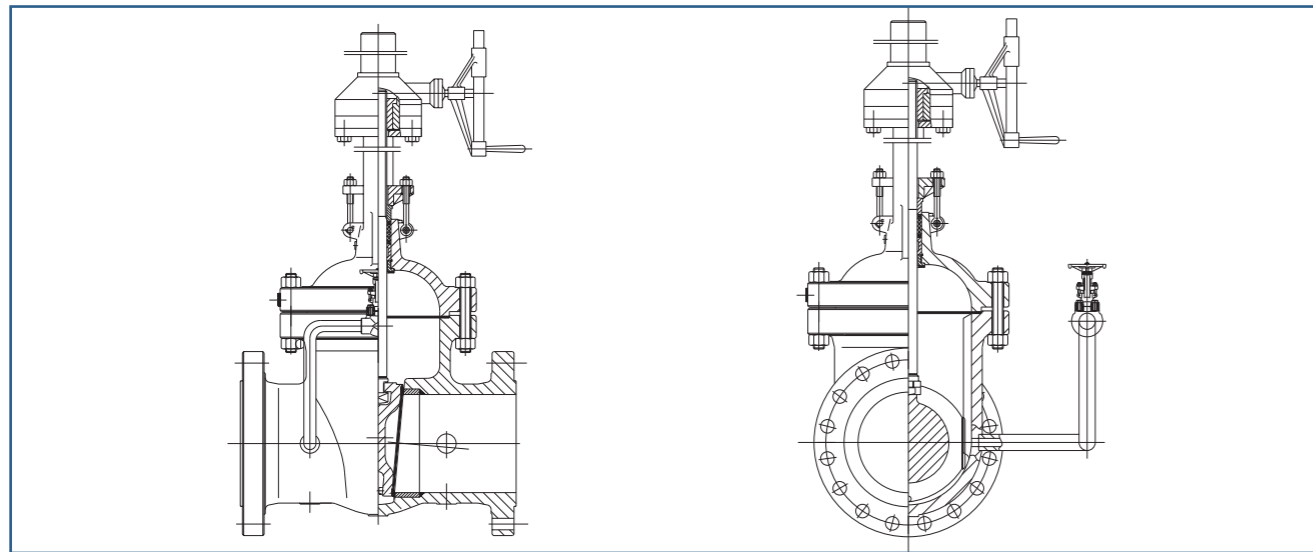

Special by-pass application

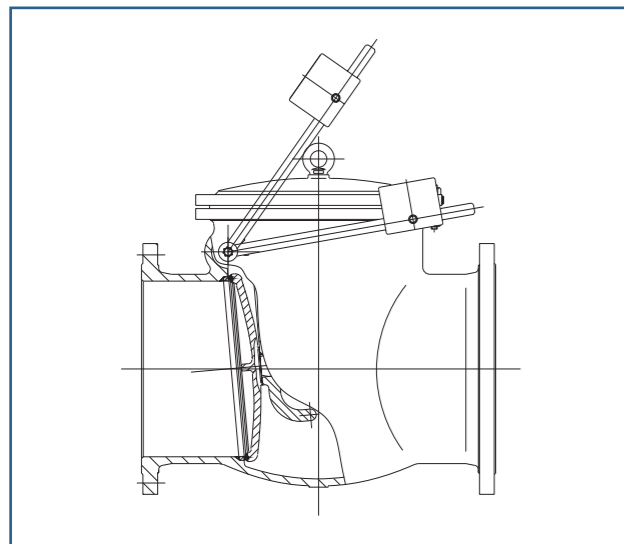

Check valves with damping box and equilibrium hammers

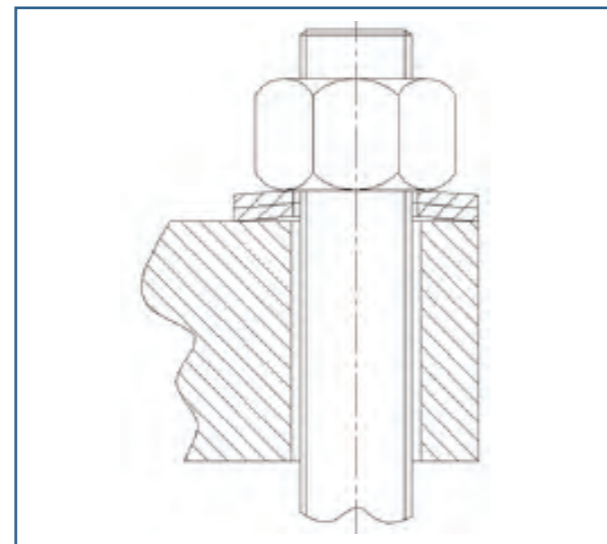

Live-loaded eye bolt

Seller will replace without charge or refund the purchase price of products provided by Seller which prove to be defective in material or workmanship, provided in each case that the product is properly installed and is used in the service for which Seller recommends it and that written claim, specifying the alleged defect, is presented to the Seller within 18 months from the date of shipment or 12 months after installation, whichever occurs first. Seller shall in no event bear any labor, equipment, engineering or other costs incurred in connection with repair or replacement. The warranty stated in this paragraph is in lieu of all other warranties, either expressed or implied. With respect to warranties, this paragraph states Buyer's exclusive remedy and seller's exclusive liability.