



**THE GLOBAL SUPPLIER
FOR GLOBAL DEMANDS**



**PRODUCT
CATALOGUE**

INDUSTRIAL SEALING DIVISION

All information and recommendations contained in this publication are to the best of our knowledge correct. Since conditions of use are beyond our control users must satisfy themselves that products are suitable for the intended processes and uses. No warranty is given or implied in respect of information or recommendations or that any use of products will not infringe rights belonging to other parties. In any event or occurrence our liability is limited to our invoice value of the goods delivered by us to you. We reserve the right to change product design and properties without notice.

We believe
that our customers are
entitled to the highest standards
of quality and reliability in the
procurement and use
of our products and services.
They will find these
standards in their relationship
with Klinger.



aerospace
sector
certification
scheme

AS9100 REV C / BS EN9100:2009, ISO 9001:2008
Certificate No: FM 10571



Introduction

An Introduction to Klinger	7
Gasket Selection.....	19

Metallic Gaskets

Maxiflex Spiral Wound Gaskets.....	41
Maxiprofile Gaskets.....	61
Klinger FireSafe Corrosion Control Gasket.....	71
Metal Jacketed Gaskets	76
Maxigraph Corrugated Graphite Gaskets	79
Metallic Ring Joints	81

Sheet Material

Soft-Cut Gasket Dimensions.....	101
KLINGER Quantum	115
KLINGERTop-sil-ML1	119
KLINGERSIL.....	123
KLINGERTop-graph-2000.....	135
Graphite	139
KLINGERTop-chem.....	147
PTFE	153
GORE Sealant Technologies	159
High Temperature.....	167
Paper, Cork & Rubber.....	173
Insulation Sets.....	185

Compression packing

Packing Selection.....	200
PTFE Packings.....	209
Graphite & Carbon Packings	217
Synthetic Fibre Packings	227
Hybrid Packings.....	235

Klinger-Acorn Hydraulic Seals

Compound Selection for Hydraulic Seals	242
O-Rings; Typical Arrangements & Clearances.....	244
O-Ring Dimension Reference Guide	246
Contoured Backup Rings for O-Rings.....	257
Geopak Hydraulic Seals	260
Piston & Rod Seals	264
Wiper Rings	268
Wear Rings.....	271
Bonded Washers.....	272
Moulded Rubber & Chevron Seals.....	273
Super Lube Range	274
O-Ring Accessories	278
Chemical Resistance Charts for Hydraulic Seal	279

Additional Products.....	283
---------------------------------	------------

An Introduction to Klinger

The Klinger Group has been a world leader in the development, manufacture and distribution of quality fluid sealing and control products since its inception in 1886 by Austrian engineer Richard Klinger. From the revolutionary development of the compressed fibre gasket to the advanced sealing material technology of today, product innovation and problem-solving abilities have always been the cornerstones of Klinger's operating philosophy.

Presently, over 40 companies and more than 80 distribution companies represent the Klinger organisation throughout the world, making it one of the worlds' leading sealing companies. Many industries rely on Klinger for their fluid sealing and control needs - petrochemical and chemical, exploration, paper, mining, steel, shipbuilding and original equipment manufacturers to name but a few. Companies in these sectors know Klinger stands behind its products with a wealth of research and development along with unmatched experience and dedication to customer service.

The group has two major static sealing divisions:

Industrial Sealing

The industrial sealing division of Klinger develops, manufactures and sells a complete range of static sealing products for general industrial applications.

Key user industries are the petrochemical and chemical industries, aerospace, food, paper, mining, steel, shipbuilding, valve manufacture and many more.

Service & Distribution

Klinger Service & Distribution companies offer a complete package of valves and sealing products, supported by the highest level of service and technical support associated with the Klinger name.





Klinger is committed to providing high quality products, underpinned by the highest levels of service and technical support. It is this commitment to excellence which ensures that Klinger products are found in all branches of the UK refinery, chemical, automotive, aerospace industries and of course original equipment manufacturers.

Companies in these sectors know Klinger stands behind its products with a wealth of research and development along with unmatched experience and dedication to customer service.



It is our commitment to improvement and innovation that keeps encouraging specifiers from various industries around the world to continue using KLINGER to provide their fluid and gas sealing requirements.

The experienced team ensures that the company continues to move forward and keep Klinger at the forefront of the gasket industry.

Our dedicated team at Klinger Bradford ensure our company keeps its reputation of quality service which it has built up over the years. This is why Klinger is at the forefront of the gasket industry.



Klinger Bradford



DIRECTIONS TO BRADFORD

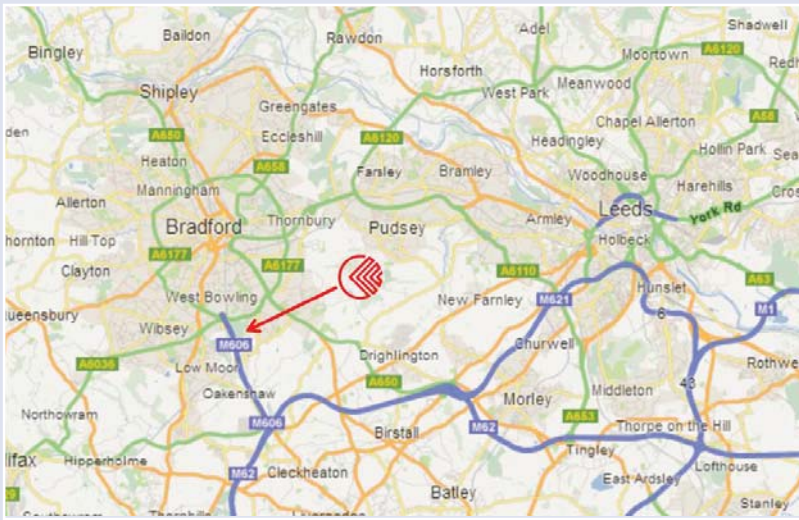

DIRECTIONS : Exit onto junction 26 off the M62 onto M606. Take the first turning onto the Euroway Trading Estate. Immediately, turn right at the lights and follow the road around a sharp left to the top of the estate.

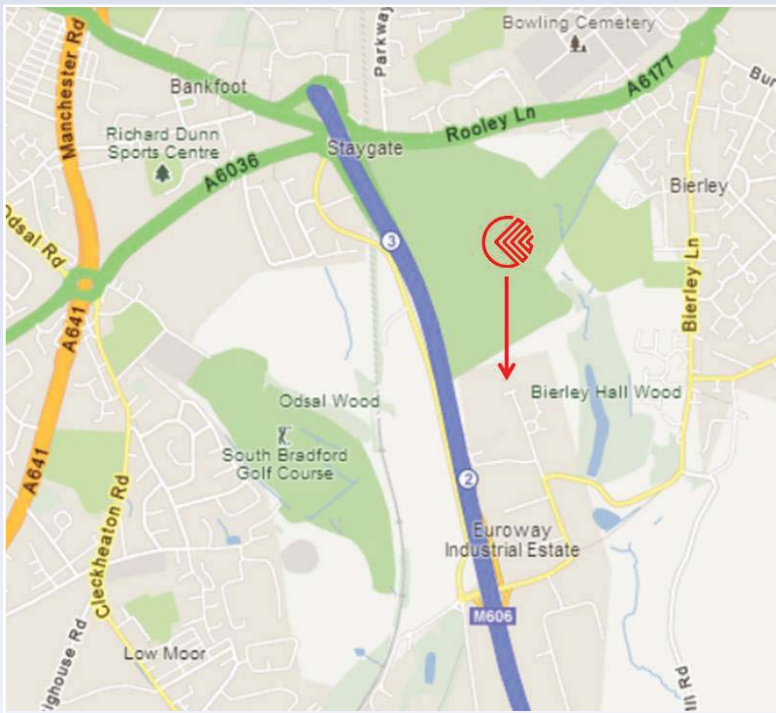

KLINGER LTD BRADFORD HEADQUARTERS

The Klinger Building, Wharfedale Road
Euroway Trading Estate, Bradford
BD4 6SG

Tel: 01274 688222

Fax: 01274 688549

E-mail: enquiries@klingeruk.co.uk

Website: www.klengeruk.co.uk

Manufacturing Excellence

Klinger manufacturing facilities are highly renowned throughout the gasket industry and Bradford is no exception. Klinger continue to move forward and improve the performance and capability of the manufacturing facility.

The development of Klinger UK's automated Maxiflex production facility has seen the company come to the forefront of spiral wound gasket manufacture. The systems used in the automation of the production plant are unique to Klinger, and ensure a consistent and reliable product allowing for greater predictability of the gasket when in service.

Using CNC controlled machinery the whole process allows an unparalleled level of quality that delivers dimensional accuracy and greater control of winding density.

These improvements over recent years have ensured that the complete manufacturing process has been able to benefit from better material utilisation, reducing cost and scrap rates to support environmental legislation.

Klinger UK is the largest manufacturer of sealing products within in its chosen field of operation in the UK and prides itself on producing high quality, effective solutions to fit the broadest range of applications.

It is our commitment to high standards of manufacture and supply that encourages specifiers from many diverse industries around the world rely on Klinger to supply their fluid and gas sealing requirements.

Moving Forward

It is Klinger's aim to continue our tradition of high standards of manufacture and supply, to ensure that we remain at the forefront of innovative gasket manufacturing.

It is a reliability record built on international and local knowledge that allows our team of product specialists to offer the best and most practical solution for any sealing application.

The innovation and adaptability of Klinger enables the company to meet the today's challenges of today and also those of the future.

Klinger have recently commissioned a cutting facility for gaskets for the aerospace industry and are now approved to BS EN 9100:2009. Klinger have also invested in further optical measurement equipment to guarantee the quality of Klinger products.



KLINGER UK BRANCH NETWORK

Klinger understand that to be successful as a service entity a populated infrastructure close to major industry is a necessity.

At all Klinger branches throughout the U.K, you will find dedicated and fully trained staff available 24 hours a day, who are able to fulfil your gasket requirements to ensure down-time is kept to a minimum.

The Klinger branch network is unique within the gasket sector, and further demonstrates the desire of Klinger to remain at Number 1 as a service entity.



Klinger Southampton

Klinger Southampton officially began trading as a Klinger company on 1st August 2006. Formally Solent Gaskets – the company has an excellent name and reputation in the South for providing first class service to industry in the area.

Klinger Southampton operates an in-house gasket cutting operation manned by a vastly experienced and skilled workforce which can provide special hand cut gaskets to customer requirements.

Unit 16
Parham Drive,
Boyatt Wood,
Eastleigh,
Hampshire
SO50 4NU

Tel: 023 8061 1855
Fax: 023 8061 0360
E-mail: southampton@klingeruk.co.uk

Klinger Grangemouth Incorporating Acorn Seals

Grangemouth serves the local oil and petrochemical industries, manufacturing soft cut gaskets and stocking a full range of gaskets and packings.

Unit A,
Block 2,
West Mains Industrial Estate,
Grangemouth,
Scotland
FK3 8YE

Tel: 01324 472231
Fax: 01324 482111
E-mail: grangemouth@klingeruk.co.uk
acorn@klingeruk.co.uk

Klinger Aberdeen

Klinger Ltd. Aberdeen mainly serves the offshore and exploration and general companies and supplies a comprehensive range of sealing products including metal ring type joints, spiral wound gaskets and packings. This branch also manufactures soft cut gaskets

Unit 31,
South Wellheads Centre,
Wellheads Crescent,
Dyce,
Aberdeen,
AB21 7GA

Tel: 01224 772962
Fax: 01224 772953
E-mail: aberdeen@klingeruk.co.uk

Klinger Runcorn

Runcorn supply local industry with a comprehensive range of Klinger gaskets and packings. The cutting department is essential for the large overhauls where fast response time is required

Unit 21,
Dewar Court,
Astmoor Industrial Estate,
Runcorn,
Cheshire,
WA7 1PT

Tel: 01928 577030
Fax: 01928 575223
E-mail: runcorn@klingeruk.co.uk

Klinger Middlesbrough

Middlesbrough serves the local chemical industry. Custom built premises manufacture soft cut gaskets and stock a complete range of Klinger sealing products.

Klinger Unit,
Drake Court,
Britannia Park,
Middlesbrough,
TS2 1RS

Tel: 01642 220289
Fax: 01642 220290
E-Mail: boro@klingeruk.co.uk
hadleys@klingeruk.co.uk

Klinger Immingham

Immingham supply local industry with a comprehensive range of Klinger gaskets and packings. The cutting department is essential for the large overhauls where fast response time is required. A full range of metallic and semi-metallic gaskets held in stock

Unit 2,
Manby Road Industrial Estate,
Immingham
North East Lincolnshire,
DN40 2LF

Tel: 0844 967 6778
Fax: 0844 967 6779
E-mail: immingham@klingeruk.co.uk



Klinger Projects

Klinger Projects is a dedicated department within Klinger UK that specialises in the supply of products and services to the project engineering and construction industries world wide.

The Projects Group has established a focused way of conducting business with E & C customers. This has been achieved by bringing together a group of people who deal exclusively with the contracting industry on a worldwide basis.

Our UK based project personnel are highly experienced in supplying sealing materials for major contractors involved with new build projects including:

Onshore plants ranging from grass root refineries, onshore gas plants, LNG, GTL & various chemical plants. Offshore installations, both concrete & steel jackets / platforms, subsea installations and more recently FPSO's.

The Projects Group is responsible for ALL aspects of enquiries and orders from initial bidding through to final stages:

- Initial tender / bid
- Technical review
- Clarifications & negotiations
- Order acceptance & processing
- Production scheduling, control, expediting
- Documentation
- QA Requirements
- Certification
- Packing and delivery
- After sales care including SPIR forms etc.

Klinger Projects

Based at Klinger Ltd Bradford
The Klinger Building,
Wharfedale Road,
Euroway Trading Estate,
Bradford,
BD4 6SG

Tel: +44 (0)1274 688222

Fax: +44 (0)1274 688962

E-mail: projects@klingeruk.co.uk



Klinger International

Klinger International specialises in supplying the local sealing requirements of Oil Majors and local representatives, for existing plants on routine maintenance and shut down activities. Offering the highest levels of service and expertise combined with a quality and comprehensive product portfolio, our Klinger International department is best placed to meet the demands for sealing products throughout the Middle East, Africa and Asia.

Klinger International department holds several successful long-term supply agreements achieved through proven on-time deliveries and professional commercial and technical tenders. Complementing the tendering process and during the course of all supply agreements many beneficial services are offered including the review of plant inventory with the aim of reducing overstocking of duplicated equipment; and in-depth training of plant personnel for product identification, safety, handling and installation.

Key activities:-

- Store surveys
- Plant product rationalisation
- Product training
- Long term supply agreements
- Localised agency and manufacturing service centres

Working closely with the Klinger Projects Department to offer a highly valued aftermarket service for New Build plants, this ensuring that the same quality Klinger sealing products can be used to maintain the plant as was used during the initial construction phase. Where possible, localised manufacturing and service centres can be established to meet any urgent gasket requirements.

Our manufacturing capability extends world-wide. Through our network of international business, Klinger Ltd offers high quality and service to the local industries.

Klinger International

Based at Klinger Ltd Bradford
 The Klinger Building
 Wharfedale Road
 Euroway Trading Estate
 Bradford,
 BD4 6SG,
 Tel: + 44 (0) 1274 688 222
 Fax: + 44 (0) 1274 688 962
 Email: international@klingeruk.co.uk



Providing Quality Service

Klinger Limited are committed to providing the highest levels of technical support to all our customers. Our skilled engineers offer practical advice and, if necessary, on-site assistance to help in the selection and fitting of our products.

As further support, the company offers training seminars either at our company headquarters or on site, as you prefer. These sessions provide an ideal opportunity for face to face, practical presentations on product selection and installation and allow site-specific issues to be raised.

There is also a dedicated quality control department which is there to help achieve the highest manufacturing standards possible, and to ensure that any problems are rectified quickly and precisely.

Development and Training

Klinger have recently added a Jjenco Flange Assembly Demonstration Unit (FADU) to the test laboratory. The FADU facilitates quick and easy compression testing for improved product development.

The FADU also allows Klinger to demonstrate the factors affecting the torque-preload relationship such as lubrication, torque wrench accuracy and stress relaxation. It also helps training allowing the user to instantly view the effects of correct and incorrect gasket installation techniques and tightening sequences.



Klinger FADU Testing Facility

Product Testing Service

Our purpose built testing facilities at Bradford allow the assessment of gasket performance under a wide range of conditions likely to be encountered in industry. This is especially valuable in selecting gaskets for new applications, giving complete safety and reliability. Our testing capabilities ranges from 1" to 24" flanges in a variety of pressure classes, also we are able to carry out specific customer designed tests, providing one of the most comprehensive testing services in the world.



KLINGERexpert

KLINGERexpert is a software package that contains data on many Klinger materials and carries out sealing calculations for new plants, new equipment and maintenance work - it is an excellent problem solver.



The user-friendly screen management is supplemented by an easy to understand on-line manual allowing you to access the most up to date information immediately on your PC.

The KLINGERexpert program is now available to download on iPhone, iPad, Android smartphones and tablets.



For any other technical assistance, please contact the technical department on:

Tel: 01274 688 222
 Fax: 01274 652 366
 E-mail: technicalservices@klingeruk.co.uk



Gasket Design

Gasket Selection



Storage Considerations



Bolt & Flange Considerations



With heightened awareness of safety and environmental issues, reducing leaks from flanged assemblies has become major priority for industry. It is therefore important for companies who use gaskets to choose the correct material for the job and to install and maintain it correctly to ensure optimum performance.

This catalogue provides a step-by-step guide to help you select and assemble our sealing products in order to achieve a safe and reliable flange connection. Should you have any doubt with regard to selecting the correct product or require advice on fitting of our products please contact our Technical Department who will gladly put their expertise at your disposal.

Selection Procedure

1. Check the chart and pressure capability guidelines on the following pages to determine the most likely gasket type for your application. These charts provide general guidelines on the operational limits of our gasket materials. Since a number of factors affect a materials suitability for a particular application, these surveys should be seen as the first step in the selection process, rather than the sole means for gasket selection.
2. Check details on pages 23 and 24 for specific service information.
3. Check your choice(s) for chemical compatibility (see pages 31 to 35). The information given in this chart should be considered a general guide only. If in any doubt, or if additional information on fluid compatibility is required, please contact our technical services department.
4. Check your choice for pressure / temperature capability using the PT diagrams for each gasket material.
5. Follow guidelines on storage, handling and assembly given on pages 28 to 30.

The matrix below can be used to help identify the most suitable type of gasket or gasket material. The details provide a starting point to select the right gasket for your application.

The matrix can also be used to aid rationalisation and select a material to satisfy a range of applications



		Quantum & Quantum FDA	Top-Sil-ML1	KLINGERSIL C-4430	KLINGERSIL C-4500	KLINGERSIL C-4400	KLINGERSIL C-4324	KLINGERSIL C-6307	KLINGERSIL C-8200	KLINGERSIL C-4106	Top-Graph-2000	GRAPHITE PSM-AS	GRAPHITE SLS	Soft-chem	Top-Chem-2000	Top-Chem-2003	Top-Chem-2005	Top-Chem-2006	Maxiflex	Maxiprofile	
Chemicals	Up to 500°C											•	•						•	•	
	Up to 400°C	•	•									•	•							•	•
	Up to 250°C	•	•	•	•	•	•	•			•	•	•	•	•	•	•	•	•	•	•
	Up to 150°C	•	•	•	•	•	•	•	•	•	•	•	•	•	•	•	•	•	•	•	•
Water & Steam	Up to 600°C																			•	•
	Up to 500°C											•	•							•	•
	Up to 300°C	•	•	•	•						•	•	•							•	•
	Up to 250°C	•	•	•	•	•	•	•	•	•	•	•	•	•	•	•	•	•	•	•	•
	Up to 150°C	•	•	•	•	•	•	•	•	•	•	•	•	•	•	•	•	•	•	•	•
Special Applications	Oxygen	•	•	•	•	•					•	•	•	•	•	•	•	•	•	•	•
	Potable water	•	•	•			•					•	•	•	•	•	•	•			
	Food industry	•	•	•			•					•	•	•	•	•	•	•	•	•	•
	Acids	•	•	•	•				•			•	•	•	•	•	•	•	•	•	•
	Caustics	•	•	•	•				•		•	•	•	•	•	•	•	•	•	•	•

Key

- Recommended
- Acceptable
- Possibly suitable

PRESSURE CAPABILITY GUIDELINES



A gasket must be suitable for the internal pressure being sealed. Generally, as the internal pressure rises, the assembly stress required to seal the application increases and therefore higher-pressure applications require a gasket material capable of withstanding high assembly loads. This is the major reason why semi-metallic and metallic gaskets are selected for high pressure applications.

The chart below provides a guide to the suitability of our materials in standard ANSI flanges. The guidelines reflect common custom and practices for size 1/2" to 24" inclusively. It should be noted that the ability to withstand assembly load is also dependent on the temperature of the application.

Generally the higher the application temperature, the lower the pressure a gasket can withstand and therefore gasket selection must be checked with the pressure/temperature graphs given for each material.

Typical Gasket Limitations

Materials	Class 150 (20 Bar)	Class 300 (50 Bar)	Class 600 (100 Bar)	Class 900 (155 Bar)	Class 1500 (260 Bar)	Class 2500 (430 Bar)
Rubber, Statite	✓	✗	✗	✗	✗	✗
KLINGERSIL C-8200	✓	✓	✗	✗	✗	✗
KLINGERSIL C-4324, C-4400	✓	✓	✗	✗	✗	✗
KLINGER Quantum, KLINGERTop-sil-ML1, KLINGERSIL C-4430, C-4500, top-graph-2000	✓	✓	✓	✗	✗	✗
top-chem-2000	✓	✓	✓	✗	✗	✗
top-chem-2003, Gore GR, Gore UPG	✓	✓	✗	✗	✗	✗
Graphite Laminates	✓	✓	✓	✗	✗	✗
Semi- Metallics	✓	✓	✓	✓	✓	✓

Steam duty is one of the most common and one of the most difficult gasket applications. It is problematic for many reasons including:

1. Steam is a powerful hydrolyser capable of changing the nature of many polymers and fibres.
2. Saturated steam has a distinct temperature/pressure relationship. Steam pressure increases with temperature, this increased pressure must be counteracted by increased gasket stress. However the maximum stress of a gasket often decreases with increased temperature.
3. Many materials can harden in steam leading in some cases to embrittlement.

When discussing temperature limits in steam, only approximate guidelines can be offered because of considerations such as :-

- Flange design (e.g. spigot and recess is far better than raised face)
- Gasket thickness (thinner gaskets are stronger in compression and are easier to seal)
- Service life required
- Assembly procedures
- Maintenance procedures
- The degrees of acceptable embrittlement of the gasket
- The use of jointing compounds on assembly (not recommended)

If the gasket is to be subjected to non-static loading and stress fluctuations due to temperature and pressure cycling, it is advisable to select a gasket material which is not prone to embrittlement with increasing temperature (e.g. Graphite Laminates or top-chem-2000). In cyclic loading conditions we recommend a minimum surface stress of 30MPa.

Bearing this in mind we suggest the following guidelines for maximum steam temperatures for Klinger materials:

Material Type	Material	Recommended Maximum Steam Temperature
Semi-Metallic	Metallic element / Graphite	550°C
Graphite Laminate	Graphite Laminate PSM-AS, SLS	460°C
High Temperature Compressed Fibre	KLINGER Quantum	350°C
Heavy-Duty Modified PTFE	top-chem-2000	260°C
Multi-layer Compressed Fibre	top-sil-ML1	250°C
Premium Compressed Fibre	KLINGERSIL C-4430, C-4500, top-graph-2000	200°C
Modified PTFE	top-chem-2003, Gore GR, Gore UPG	200°C
Standard Compressed Fibre	KLINGERSIL C-4400, C-4324	150°C

The above values are for guidance only. Higher temperatures can be accommodated if the service is static or the gasket is highly loaded. Conversely, the temperatures should be reduced if the conditions are cyclic or if sufficient load cannot be guaranteed. If in doubt please consult Klinger Technical Department.

LOW TEMPERATURE DUTY



Elastomers undergo a glass transition at low temperatures. For standard rubber grades such as NBR and SBR, this point is reached between -30°C to -40°C. As the rubber passes through the glass transition, it becomes brittle and any additional stress on the material may cause cracking. However, the embrittlement is reversible and as the rubber is returned to room temperature it regains its flexibility on returning to room temperature.

KLINGERSIL grades, which contain only a small proportion of rubber and have a protective network of fibres, may be used at temperatures below the glass transition point of the rubber. The minimum temperature at which the materials will operate successfully is dependent on the application and method of assembly.

For successful service at low temperatures the following points must be observed:

- The gasket is completely dry when installed
- The flange is assembled at ambient temperature
- The flange material and bolt material are capable of functioning at the low temperature
- The gasket is not retorqued at low temperature

Provided the above practices are adopted the following general guidelines for minimum gasket service temperature apply:-

Gasket Type	Minimum Temperature
Viton rubber	-15°C
Neoprene rubber	-40°C
Nitrile rubber	-40°C
KLINGERSIL C-4324	-50°C
Natural rubber	-70°C
KLINGERtop-sil-ML1	-100°C
KLINGERSIL C-4400	-100°C
KLINGERtop-sil-ML1	-100°C
KLINGER Quantum	-196°C
KLINGERSIL C-4500	-196°C
PSM-AS & SLS	-196°C
top-chem, Softchem & Sealex	-196°C
Gore GR, UPG, DF & Series Tapes	-196°C
Maxiflex (graphite or PTFE filler)	-196°C
Maxiprofile (graphite or PTFE filler)	-196°C

Gasket Size

A general rule is that gaskets cut from sheet (e.g. KLINGERSIL, Top-sil, Qunam, top-chem, graphite laminates and top-graph-2000) can be successfully used at smaller diameters, lower pressures and lower temperatures. As diameter, temperature or pressure increases the use of semi-metallic and metallics are more common. This is largely due to the effect of the hydrostatic end thrust reducing the residual stress on the gasket and increasing the possibility of blow-out.

As a general guide, special care should be taken for gaskets above 600mm, temperatures above 200°C or pressures above 50 bar.



Gasket Thickness

It is very important to select as thin a gasket as practicable. The reasons for this are:-

1. In many cases (particularly when sealing gases) thinner material requires a lower minimum stress to create a seal.
2. Stress relaxation resistance (the ability of a gasket to withstand the effects of stress and temperature without undue thickness decrease) decreases with increasing gasket thickness.
3. Thinner material has superior load-bearing capacity. However, the gasket has to have sufficient thickness to allow for deformation to the flange surface.



Surface Finish

The surface finish on a flange increases the friction at the gasket interface and helps to prevent extrusion of the gasket outwards due to the force exerted by the internal pressure. We recommend using a gramophone or concentric grooved finish with a defined roughness.

Standard pipe flanges	3.2µm (125µ") to 6.3µm (250µ")
Tongue & groove flanges	1.6µm (63µ") to 6.3µm (250µ")

Maxiflex gaskets require a surface finish of 3.2µm to 6.3µm for most duties but can be as fine as 2.0µm (80µ") for more critical services.

Gaskets for lined and non-metallic flanges

Correct gasket selection is important for lined and non-metallic pipework systems for a number of reasons. Many lined and nonmetallic flanges tend to be of a fragile nature and the gasket must be capable of creating a seal under low bolt load. Furthermore, this type of pipework is often used on aggressive, pharmaceutical or food applications and the chosen material is required to be free from contamination and with good chemical resistance. On glass lined pipework, a gasket must be selected which is sufficiently soft and compressible to seal the undulations often present on such flanges.

We recommend the following products for lined or non-metallic pipework systems:

- For glass lined flanges, Gore UPG, Gore GR or top-chem-2003
- For rubber lined flanges Gore UPG, Gore GR, top-chem-2003 or an elastomer should be selected
- For non-metallic flanges we recommend an elastomer or Gore UPG

Gaskets for Narrow Flanges

Non-standard flanges such as those on heat exchangers often have narrow sealing faces and are traditionally sealed using semi-metallic gaskets such as the Maxiprofile. For lower pressure services, soft materials may be used provided the following guidelines are observed:

- Graphite laminate materials require a minimum width to thickness ratio of ideally 7.5:1.
- Other sheet grades can be used with a width to thickness ratio of 5:1.

There are no width to thickness limitations for semi-metallic gaskets aside from manufacturing capability.

Damaged or Warped Flanges

To ensure the optimum performance of the gasket material, flanges should be in good condition and parallel. If flanges are damaged or warped, then the flange should ideally be re-machined. If re-machining is not possible, it is necessary to fit a gasket which can accommodate the imperfections. Graphite laminate or soft PTFE gaskets such as Gore GR & UPG, top-chem-2003 or Soft-Chem are the best options from our range.

The bolts or studs in a flange assembly provide the compressive force necessary to seal the gasket and prevent leakage. Reliability of the joint depends upon achieving and maintaining an acceptable level of tension in each bolt. The target tension level is dependent on a number of factors including gasket type, bolt strength, service conditions and flange rigidity. From a gasket viewpoint, the tension applied to the bolts must be sufficient to seal the gasket under operating conditions, but not be too great so that the compressive limit of the gasket is surpassed.

Both conditions may result in leakage and failure of the joint. With respect to the bolts, the tension selected should be high enough to ensure adequate strain but not so high that the material is taken beyond its yield point. If the initial bolt stress is too low then the total amount of strain (bolt stretch) is low and in these circumstances any subsequent reduction in thickness of the gasket due to creep will quickly result in loss of bolt strain and subsequent leakage. The method employed to tighten the bolts can result in significant variations from the bolt stress anticipated.

The following table compares the typical variations for the common methods of tightening:

Method of tightening	Tools required	Typical tolerance
Wrench (no torque control)	Spanner or wrench	± 50%
Wrench (with torque control)	Calibrated torque wrench	± 30%
Hydraulic tensioner	Multiple stud tensioners	± 10% to ± 30%
Direct measurement of strain	Pre-set studs	± 5%

If using a torque wrench ensure that it is accurately calibrated. Failure due to poorly calibrated torque spanners is a common cause of problems in joint tightening. It is important that the bolts are clean and lubricated on assembly. This will improve the efficiency of the bolt (the degree to which the torque is transmitted as compressive stress to the gasket). A small increase in friction under the nut or in the threads can result in a large percentage loss in useful work.

Typical lubricants and efficiencies are:

Lubricant	Typical nut factor
No lubricant - clean mild steel studs / bolts	0.25
No lubricant - clean stainless steel studs / bolts	0.30
Zinc plated (dry)	0.29
Machine oil	0.20
Molybdenum disulphide based grease	0.15
Copper based anti-seize	0.15
Solid PTFE film	0.12

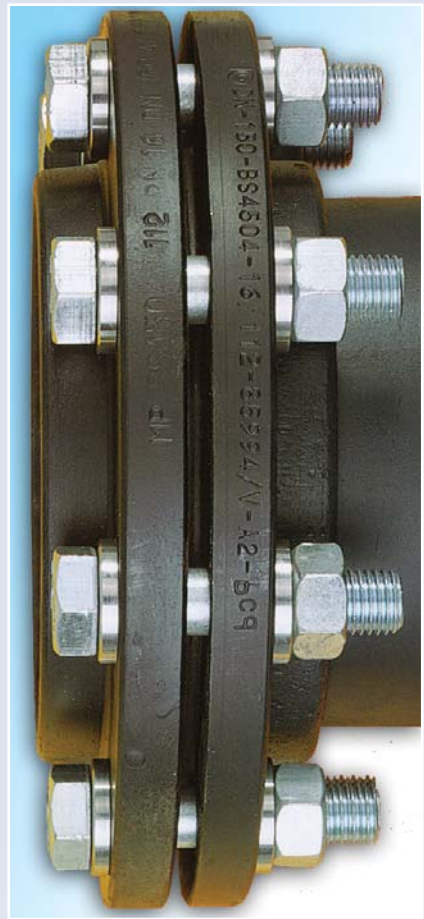



Klinger compressed fibre gasket materials, like all materials containing an elastomer, are subjected to a natural ageing process, dependent upon the type and quality of elastomer, its vulcanisation process and the storage conditions. All the KLINGERSIL, Top-Sil, Quantum and Top-Graph materials contain approximately 12% elastomer binder. Since this is a relatively small proportion, the effects of ageing are not as great for these materials as they are for a pure elastomer.

Nevertheless, poor storage conditions can lead to premature reduction in the quality of these materials, especially when conditions of increased temperature, low humidity levels and strong light exist.

In the following conditions, a useful minimum life of 5 years is guaranteed. but we do not recommend that rubber-based materials are stored for more than 7 years.

- Room temperature below 25°C
- Humidity level between 50-60 %
- Darkened storeroom
- Dry, avoid contamination with any liquids

The useful life of the material when the storage conditions differ from the recommended factors is not known. It has been established, however, that room temperature has a major influence on the shelf life of the material.

If the room temperature is around 30°C over long periods, a loss of quality can occur after 2 years.

Cut gaskets should be stored flat. This especially applies to large gaskets which when hung up might suffer stress and permanent deformation, leading to fitting difficulties and damage of the material.

Graphite-laminate materials are more fragile than compressed fibre materials and require extra care during storage, handling and fitting.

The following guidelines are designed to ensure the optimum performance of our gasket materials:

1. Choosing The Right Gasket

There are many factors which must be taken into account when choosing a gasket material for a given application including the chemical compatibility, temperature and pressure. Please refer to the information given in this catalogue or our software program; Klinger Expert for advice. If you have any questions regarding the suitability of material for a given application, please contact Klinger Technical Department.

2. Gasket Thickness

Gasket material should be as thin as possible. Increasing the thickness of the material decreases the load-bearing capacity of the gasket. Thinner materials also have better torque retention characteristics.

3. Flange Condition & Flange Surface Finish

Ensure all remains of the old gasket material are removed and the flanges are clean and in good condition. We typically recommend a flange surface finish of $3.2\mu\text{m}$ ($125\mu''$) to $6.3\mu\text{m}$ ($250\mu''$) for our gasket grades when used on standard pipe flanges. See page 26 for more details.

4. Gasket Compounds

Ensure all soft cut gaskets are installed in a dry state - the use of jointing compounds is not recommended. Releasing agents such as grease or oil containing compounds are not required and can adversely affect the material, lowering the torque retention properties. To aid gasket removal, Klinger materials have an anti-stick finish.

5. Gasket Dimensions

Ensure gasket dimensions are correct. The gasket should not intrude into the bore of the pipework and should be installed centrally.

6. Bolting

Wire brush stud/bolts and nuts (if necessary) to remove any dirt on the threads. Ensure that the nuts can run freely down the thread before use. Apply lubricant with a known friction coefficient to the bolt threads, to the nut threads and to the face of the nut to be tightened.





7. Joint Assembly

It is recommended that the bolts are tightened using a controlled method such as torque or tension, this will lead to greater accuracy and consistency than using conventional methods of tightening. If using a torque wrench, ensure that it is accurately calibrated.

For torque settings please refer the Klinger Expert or contact our Technical department who will be happy to assist you. Carefully fit the gasket into position taking care not to damage the gasket surface. When using torque, tighten bolts in at least three stages to the required torque as follows:

- Finger tighten nuts.
- Carry out tightening, making at least three complete diagonal tightening sequences i.e. 30%, 60% and 100% of final torque value.
- Continue with one final pass - torquing the bolts/studs in a clockwise sequence.

8. Retightening

Provided that the above guidelines are followed retightening of the gasket after joint assembly should not be necessary. If retightening is considered necessary e.g. in the case of thicker gaskets which are more susceptible to creep, then this should only be performed at ambient temperature before or during the first start-up phase of the pipeline or plant. Retightening of compressed fibre gaskets at higher operating temperatures and longer operating times may lead to a failure of the gasket connection and should be avoided.

9. Re-use

For safety reasons, re-use of gaskets is not advisable.

CHEMICAL RESISTANCE OF SHEET MATERIALS

Media	Formula	Klinger Quantum / Top-sil-ML1	C-4400	C-4430	C-4500	C-4509	C-8200	C-4324	Top-graph-2000	Graphite	Top-chem-2000/ 2003 Softchem	Top-chem-2005	Top-chem-2006	Milam
A														
Acetaldehyde	CH ₃ CHO	B	B	B	B	B	A	B	B	A	A	A	A	A
Acetamide	CH ₃ COCH ₂	A	A	A	A	A	A	A	A	A	A	A	A	A
Acetic acid	CH ₃ COOH	A	A	A	A	C	A	A	A	A	A	A	A	A
Acetic ether	CH ₃ COOC ₂ H ₅	B	B	B	B	B	B	B	B	A	A	A	A	A
Acetone	CH ₃ COCH ₃	B	B	B	B	B	A	B	B	A	A	A	A	A
Acetylene	C ₂ H ₂	A	A	A	A	A	A	A	A	A	A	A	A	A
Adipic acid	COOH(CH ₂) ₄ COOH	A	A	A	A	A	A	A	A	A	A	A	A	A
Alum	KAl(SO ₄) ₂	A	A	A	A	B	A	A	A	A	A	A	A	A
Aluminium acetate	(CH ₃ COO) ₃ Al	A	A	A	A	B	A	A	A	A	A	A	A	A
Aluminium chlorate	Al(ClO ₃) ₃	A	A	A	A	C	A	A	B	A	A	A	A	A
Aluminium chloride	AlCl ₃	A	A	A	A	B	A	A	A	A	A	A	A	A
Ammonia	NH ₃	A	A	A	A	A	A	A	A	A	A	B	A	A
Ammonium bicarbonate	NH ₄ HCO ₃	A	A	A	A	A	A	A	B	A	A	A	A	A
Ammonium chloride	NH ₄ Cl	A	A	A	A	C	A	A	A	A	A	A	A	A
Ammonium diphosphate	(NH ₄) ₂ HPO ₄	A	A	A	A	B	A	A	A	A	A	A	A	A
Ammonium hydroxide	NH ₄ OH	A	A	A	A	B	A	A	C	A	A	A	A	A
Amyl acetate	CHCOOC ₅ H ₁₁	B	B	B	B	B	B	B	A	A	A	A	A	A
Aniline	C ₆ H ₅ NH ₂	C	C	C	C	C	C	C	C	A	A	A	A	A
Asphalt (tar)		A	A	A	A	A	A	A	C	A	A	A	A	A
ASTM oil 1		A	A	A	A	A	A	A	A	A	A	A	A	A
ASTM oil 3		A	A	A	A	A	A	A	A	A	A	A	A	A
B														
Barium chloride	BaCl ₂	A	A	A	A	A	A	A	A	A	A	A	A	A
Benzene	C ₆ H ₆	A	A	A	A	A	A	A	A	A	A	A	A	A
Benzine		A	A	A	A	A	A	A	A	A	A	A	A	A
Benzoic acid	C ₆ H ₅ COOH	B	B	B	A	B	A	B	B	A	A	A	A	A
Bleach	Ca(OCl) ₂	A	A	A	A	C	A	A	A	A	A	A	A	A
Borax	Na ₂ B ₄ O ₇ ·10H ₂ O	A	A	A	A	A	A	A	A	A	A	A	A	A
Butane	C ₄ H ₁₀	A	A	A	A	A	A	A	A	A	A	A	A	A
Butanone		B	B	B	B	B	B	B	B	A	A	A	A	A
Butyl acetate	CHCOOC ₄ H ₉	B	B	B	B	B	B	B	A	A	A	A	A	A
Butyl alcohol (butanol)	C ₄ H ₉ OH	A	A	A	A	A	A	A	A	A	A	A	A	A
C														
Calcium chloride	CaCl ₂	A	A	A	A	B	A	A	A	A	A	A	A	A
Calcium hydroxide	Ca(OH) ₂	A	A	A	A	B	A	A	B	A	A	B	A	A
Calcium sulphate	CaSO ₄	A	A	A	A	A	A	A	A	A	A	A	A	A
Carbon dioxide	CO ₂	A	A	A	A	A	A	A	A	A	A	A	A	A
Carbon disulphide	CS ₂	C	C	C	B	C	C	C	A	A	A	A	A	A

CHEMICAL RESISTANCE OF SHEET MATERIALS

Media	Formula	Klinger Quantum / Top-sil-ML1	C-4400	C-4430	C-4500	C-4509	C-8200	C-4324	Top-graph-2000	Graphite	Top-chem-2000/2003 Soft-chem	Top-chem-2005	Top-chem-2006	Millam
Carbon tetrachloride	CCl ₄	B	B	B	B	B	C	B	B	A	A	A	A	A
Castor oil		A	A	A	A	A	A	A	A	A	A	A	A	A
Chlorine (dry)	Cl ₂	B	B	B	B	B	B	B	B	B	A	A	A	A
Chlorine water (0.5%)		A	A	A	A	C	A	A	A	B	A	A	A	A
Chlorine (wet)	Cl ₂	C	C	C	C	C	C	C	C	B	A	A	A	A
Chloroform	CHCl ₃	B	B	B	B	B	B	B	B	A	A	A	A	A
Chloromethane	CH ₃ Cl	B	B	B	B	B	B	B	B	A	A	A	A	A
Chromic acid	H ₂ CrO ₄	B	B	B	B	C	B	C	B	C	A	A	A	A
Citric acid	(CH ₂ COOH) ₂ C(OH)COOH	A	A	A	A	A	A	A	A	A	A	A	A	A
Clophen	T64	B	B	B	B	B	B	B	B	A	A	A	A	A
Copper acetate	(CH ₃ COO) ₂ Cu	A	A	A	A	A	A	A	A	A	A	A	A	A
Copper sulphate	CuS ₄	A	A	A	A	A	A	A	A	A	A	A	A	A
Creosote		C	C	C	C	C	C	C	C	A	A	A	A	A
Cresol	C ₆ H ₄ (OH)CH ₃	B	B	B	B	B	B	B	C	A	A	A	A	A
Cyclohexanol	C ₆ H ₁₁ OH	A	A	A	A	A	A	A	A	A	A	A	A	A
Cyclohexanone	C ₆ H ₁₀ O	C	C	C	C	C	C	C	C	A	A	A	A	A
D														
Decalin	C ₁₀ H ₁₈	A	A	A	A	A	A	A	A	A	A	A	A	A
Di-benzylether	(C ₆ H ₅ CH ₂) ₂ O	C	C	C	C	C	C	C	B	A	A	A	A	A
Di-butylphthalate	C ₆ H ₄ (COOC ₄ H ₉) ₂	A	A	A	A	A	A	A	A	A	A	A	A	A
Dimethylformamide	HCON(CH ₃) ₂	C	C	C	C	C	C	C	C	A	A	A	A	A
Diphyl (Dowtherm A)		A	A	A	A	A	A	A	A	A	A	A	A	A
E														
Ethane	C ₂ H ₆	A	A	A	A	A	A	A	A	A	A	A	A	A
Ethyl acetate	CH ₃ COOC ₂ H ₅	B	B	B	B	B	B	B	A	A	A	A	A	A
Ethyl alcohol (Ethanol)	C ₂ H ₅ OH	A	A	A	A	A	A	A	A	A	A	A	A	A
Ethyl chloride	C ₂ H ₅ Cl	B	B	B	B	B	B	B	B	A	A	A	A	A
Ethyl ether	C ₂ H ₅ OC ₂ H ₅	A	A	A	A	A	A	A	A	A	A	A	A	A
Ethylene chloride	(CH ₂ Cl) ₂	C	C	C	C	C	A	C	C	A	A	A	A	A
Ethylene glycol	(CH ₂ OH) ₂	A	A	A	A	A	A	A	A	A	A	A	A	A
F														
Formaldehyde	CH ₂ O	A	A	A	A	A	A	A	B	A	A	A	A	A
Formamide	HCONH ₂	B	B	B	A	B	B	B	B	A	A	A	A	A
Freon 12		A	A	A	A	A	A	A	A	A	A	A	A	A
Freon 22		B	B	B	B	B	A	B	A	A	A	A	A	A
G														
Glucose	C ₆ H ₁₂ O ₆	A	A	A	A	A	A	A	A	A	A	A	A	A

CHEMICAL RESISTANCE OF SHEET MATERIALS

Media	Formula	Klinger Quantum / Top-sil-ML1	C-4400	C-4430	C-4500	C-4509	C-8200	C-4324	Top-graph-2000	Graphite	Top-chem-2000/2003 Soft-chem	Top-chem-2005	Top-chem-2006	Milam
Glycerine	(CH ₂ OH) ₂ CHOH	A	A	A	A	A	A	A	A	A	A	A	A	A
H														
Heptane	C ₇ H ₁₆	A	A	A	A	A	A	A	A	A	A	A	A	A
Hydraulic oil (mineral/Glycol)		A	A	A	A	B	A	A	A	A	A	A	A	A
Hydraulic oil (phosphate ester)		B	B	B	B	B	B	B	B	A	A	A	A	A
Hydrazine hydrate	(NH ₂) ₂ H ₂ O	A	A	A	A	A	A	A	A	A	A	A	A	A
Hydrochloric acid (20%)	HCl	B	B	B	B	C	A	B	B	A	A	A	C	A
Hydrochloric acid (30%)	HCl	C	C	C	C	C	A	C	C	A	A	A	C	A
Hydrofluoric acid (10%)	HF	C	C	C	C	C	A	C	C	A	A	C	C	A
Hydrogen	H ₂	A	A	A	A	B	A	A	A	A	A	A	A	A
Hydrogen peroxide (<6%ww)	H ₂ O ₂	A	A	A	A	C	A	A	C	A	A	A	A	A
I														
Iso-octane	(CH ₃) ₂ CCH ₂ (CH ₃) ₂	A	A	A	A	A	A	A	A	A	A	A	A	A
Iso-propyl alcohol	(CH ₃) ₂ CHOH	A	A	A	A	A	A	A	A	A	A	A	A	A
K														
Kerosene (petroleum)		A	A	A	A	A	A	A	A	A	A	A	A	A
L														
Lead acetate	(CH ₃ COO) ₂ Pb	A	A	A	A	A	A	A	A	A	A	A	A	A
Lead arsenate	Pb ₃ (AsO ₄) ₂	A	A	A	A	A	A	A	A	A	A	A	A	A
M														
Magnesium sulphate	MgSO ₄	A	A	A	A	A	A	A	A	A	A	A	A	A
Methane	CH ₄	A	A	A	A	A	A	A	A	A	A	A	A	A
Methyl alcohol	CH ₃ OH	A	A	A	A	A	A	A	A	A	A	A	A	A
Methyl chloride	CH ₃ Cl	B	B	B	B	B	B	B	B	A	A	A	A	A
Methyl ethyl ketone	CH ₃ COO ₂ H ₅	B	B	B	B	B	B	B	B	A	A	A	A	A
Methylene chloride	CH ₂ Cl ₂	C	C	C	C	C	B	C	B	A	A	A	A	A
N														
Naphtha		A	A	A	A	A	A	A	A	A	A	A	A	A
Nitrobenzene	C ₆ H ₅ NO ₂	C	C	C	C	C	C	C	C	A	A	A	A	A
Nitrogen	N ₂	A	A	A	A	A	A	A	A	A	A	A	A	A
Nitric Acid	HNO ₃	C	C	C	C	C	B	C	C	C	A	A	B	A
O														
Octane	C ₈ H ₁₈	A	A	A	A	A	A	A	A	A	A	A	A	A
Oleum (fuming sulphuric acid)		C	C	C	C	C	C	C	C	C	A	A	C	A

CHEMICAL RESISTANCE OF SHEET MATERIALS

Media	Formula	Klinger Quantum / Top-sil-ML1	C-4400	C-4430	C-4500	C-4509	C-8200	C-4324	Top-graph-2000	Graphite	Top-chem-2000/2003 Soft-chem	Top-chem-2005	Top-chem-2006	Millam
Oxalic acid	$\text{HO}_2\text{CCO}_2\text{H}$	B	B	B	B	B	A	B	B	A	A	A	A	A
Oxygen	O_2	A	A	A	A	B	A	A	B	A	A	A	A	A
P														
Pentane	C_5H_{12}	A	A	A	A	A	A	A	A	A	A	A	A	A
Perchloroethylene	C_2Cl_4	B	B	B	B	B	B	B	B	A	A	A	A	A
Petroleum ether		A	A	A	A	A	A	A	A	A	A	A	A	A
Phenol	$\text{C}_6\text{H}_5\text{OH}$	C	C	C	C	C	B	C	C	A	A	A	A	A
Phosphoric acid	H_3PO_4	A	A	A	A	C	A	C	A	A	A	A	A	A
Phthalic acid	$(\text{C}_6\text{H}_4\text{COOH})_2$	A	A	A	A	A	A	A	A	A	A	A	A	A
Potassium acetate	CH_3COOK	A	A	A	A	A	A	A	A	A	A	A	A	A
Potassium carbonate	K_2CO_3	A	A	A	A	A	A	A	B	A	A	A	A	A
Potassium chlorate	KClO_3	A	A	A	A	C	A	A	A	B	A	A	A	A
Potassium chloride	KCl	A	A	A	A	A	A	A	A	A	A	A	A	A
Potassium cyanide	KCN	A	A	A	A	A	A	A	A	A	A	A	A	A
Potassium dichromate	$\text{K}_2\text{Cr}_2\text{O}_7$	A	A	A	A	B	A	A	A	B	A	A	A	A
Potassium hydroxide	KOH	B	B	B	A	B	A	B	B	A	A	C	A	A
Potassium hypochlorite	KClO	A	A	A	A	C	A	B	A	B	A	A	A	A
Potassium nitrate	KNO_3	A	A	A	A	A	A	A	A	A	A	A	A	A
Potassium permanganate	KMnO_4	A	A	A	A	A	A	A	A	B	A	A	A	A
Propane	C_3H_8	A	A	A	A	A	A	A	A	A	A	A	A	A
Pyridine	$\text{C}_5\text{H}_5\text{N}$	C	C	C	C	C	C	C	C	A	A	A	A	A
S														
Salt	NaCl	A	A	A	A	A	A	A	A	A	A	A	A	A
Silicone oil		A	A	A	A	A	A	A	A	A	A	A	A	A
Soda	Na_2CO_3	A	A	A	A	A	A	A	A	A	A	C	A	A
Sodium aluminate	Na_2AlO_3	A	A	A	A	A	A	A	A	A	A	A	A	A
Sodium bisulphite	NaHSO_3	A	A	A	A	B	A	A	A	A	A	A	A	A
Sodium carbonate	NaHCO_3	A	A	A	A	A	A	A	A	A	A	A	A	A
Sodium chloride	NaCl	A	A	A	A	A	A	A	A	A	A	A	A	A
Sodium cyanide	NaCN	A	A	A	A	A	A	A	A	A	A	A	A	A
Sodium hydroxide	NaOH	B	B	B	A	B	A	B	B	A	A	C	A	A
Sodium silicate (water glass)		A	A	A	A	A	A	A	A	A	A	A	A	A
Sodium sulphate	Na_2SO_4	A	A	A	A	A	A	A	A	A	A	A	A	A
Sodium sulphide	Na_2S	A	A	A	A	A	A	A	A	A	A	A	A	A
Steam	H_2O	B	B	B	B	B	B	B	A	A	B	B	B	A
Stearic acid	$\text{C}_{17}\text{H}_{33}\text{COOH}$	A	A	A	A	A	A	A	A	A	A	A	A	A
Sulphur dioxide	SO_2	C	C	C	B	C	A	C	B	A	A	A	A	A
Sulphuric acid	H_2SO_4	C	C	C	C	C	A	C	C	B	A	A	C	A
T														

CHEMICAL RESISTANCE OF SHEET MATERIALS

Media	Formula	Klinger Quantum / Top-sil-ML1	C-4400	C-4430	C-4500	C-4509	C-8200	C-4324	Top-graph-2000	Graphite	Top-chem-2000/2003 Soft-chem	Top-chem-2005	Top-chem-2006	Milam
Tetrachloroethane	$C_2H_2Cl_4$	B	B	B	B	B	B	B	B	A	A	A	A	A
Tetraline	$C_{10}H_{12}$	A	A	A	A	A	A	A	A	A	A	A	A	A
Toluene	$C_6H_5CH_3$	A	A	A	A	A	A	A	A	A	A	A	A	A
Transformer oil		A	A	A	A	A	B	A	A	A	A	A	A	A
Trichloroethylene	C_2HCl_3	B	B	B	B	B	B	B	B	A	A	A	A	A
Triethanolamine	$N(CH_2CH_2OHO)_3$	A	A	A	A	A	A	A	A	A	A	A	A	A
U														
Urea	$(NH_2)_2CO$	A	A	A	A	A	A	A	A	A	A	A	A	A
V														
Vinyl acetate	$CH_3COOC_2H_3$	A	A	A	A	A	A	A	A	A	A	A	A	A
W														
Water	H_2O	A	A	A	A	A	A	A	A	A	A	A	A	A
Water glass	Na_2SiO_3	A	A	A	A	A	A	A	A	A	A	A	A	A
X														
Xylol	$C_6H_4(CH_3)_2$	A	A	A	A	A	A	A	A	A	A	A	A	A

A - Suitable

B - Suitability depends on operating conditions

C - Not suitable



Spiral Wound Gaskets

Metallic



Metallic Ring Joints

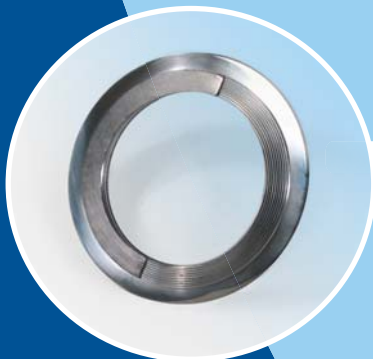

Maxiprofile

Maxiflex

Introduction to Maxiflex..... 42
 Maxiflex Styles 44
 Graphite Filled..... 46
 PTFE Filled..... 47
 Mica Filled..... 48
 MaxiZonal 49

 Maxiflex PRO & Maxiflex PRO-X 50

 Dimension Tables..... 51

Maxiprofile

Introduction to Maxiprofiles..... 62
 Maxiprofile Properties..... 64
 Maxiprofile Dimension Tables 67

Klinger Fire Safe Corrosion Control Gasket 71
 Metal Jacketed Gaskets..... 76
 Type 108 78
 Maxigraph Corrugated Graphite Gaskets..... 79

Ring Type Joints

Type R Oval..... 83
 Type R Octagonal..... 87
 Type RX..... 91
 Type BX..... 93
 IX Seals..... 95

Metallic

Maxiflex



MAXIFLEX SPIRAL WOUND GASKETS

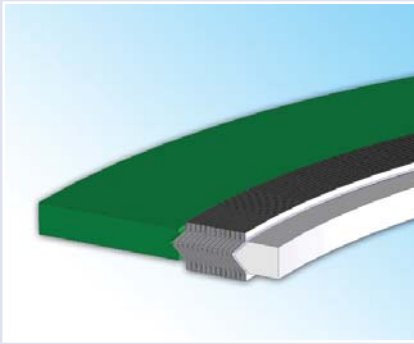

Spiral wound gaskets have the ability to recover under the action of fluctuating loads caused by process fluid pressure and temperature changes, flange face temperature variations, flange rotation, bolt stress relaxation and creep.

The gasket sealing element consists of a pre-formed metallic winding strip with layers of a softer, more compressible sealing material which, during compression, is densified and flows to fill imperfections in the flange surfaces when the gasket is seated. The metal strip holds the filler giving the gasket mechanical resistance and resilience.

Maxiflex gaskets can be manufactured from a range of filler materials according to different service conditions :

Filler Material	Maximum Temperature	ASME B16.20 Colour Coding
Graphite	500°C	Grey Stripe
PTFE	260°C	White Stripe
Mica	1000°C	Light Green Stripe
Mica and Graphite	900°C	-

Winding Material	Maximum Temperature	ASME B16.20 Colour Coding
Carbon Steel	500°C	Silver
304 Stainless Steel	650°C	Yellow
316L Stainless Steel	800°C	Green
Duplex UN S31803	800°C	N/A
347 Stainless Steel	800°C	Blue
321 Stainless Steel	800°C	Turquoise
Monel 400	450°C	Orange
Nickel 200	315°C	Red
Titanium Gr 2	350°C	Purple
Hastelloy B-2/B-3	450°C	Brown
Hastelloy C-276	450°C	Beige
Inconel 600	1000°C	Gold
Inconel 625	450°C	Gold
Inconel X-750	1000°C	N/A
Incoloy 825	450°C	N/A
Zirconium	500°C	N/A
Super Duplex	600°C	N/A
254 SMO	600°C	N/A
Titanium Gr7	350°C	N/A
Hastelloy C-22	450°C	N/A
Hastelloy G-31	450°C	N/A
Alloy 20	600°C	N/A

Please note:

These temperatures given above are guidelines only and do not apply in all fluids, Please contact Technical Department for advice.

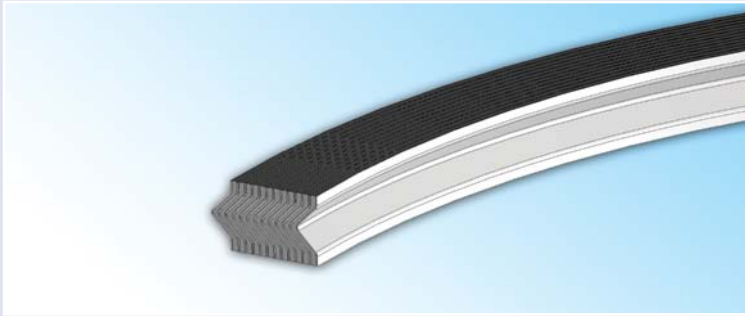

This is the “Maxiflex” spiral wound gasket’s basic sealing element. Several layers of specially formed continuous V-shaped metal strip are spirally wound with alternate plies of soft filler strip. The “V” profile allows the gasket to act as a spring and the depth is carefully controlled to bestow the sealing element with the best compression and recovery characteristics. In order to further enhance the mechanical and sealing properties of the gasket, it is normal practice to apply several layers of the metal strip only to the inner and outer diameters.

Computer-controlled winding machines carefully monitor and adjust the tension of the winding strips. A uniform density throughout the product is produced. This provides the spring-like action within the gasket which enables it to maintain a seal even when subject to fluctuating compressive loads.

Flange Surface Finish

Maxiflex gaskets are capable of giving an excellent seal over a wide range of flange surface finishes, but as a general guide we suggest the following:

Duty	Roughness	
General	3.2-6.3µm	125-200µ”
Critical	3.2µm	125µ”
Vacuum	2.0µm	80µ”

Thickness of Maxiflex Gaskets

Spiral wound gaskets are manufactured with a number of standard thicknesses which are designed to compress to a specific thickness to attain the best sealing performance and adaptation to the flanges. The thickness is measured to the metallic windings not to the filler. The standard thicknesses are as follows:

Initial thickness	Thickness after installation
2.5mm	2.0mm
3.2mm	2.5mm
4.5mm	3.0-3.2mm
6.4mm	4.6-4.8mm
7.2mm	4.8-5.0mm

Metallic

MAXIFLEX SPIRAL WOUND GASKETS

Maxiflex Spiral Wound Gaskets are available in a range of configurations and materials. Below are the most common gasket types.

Metallic

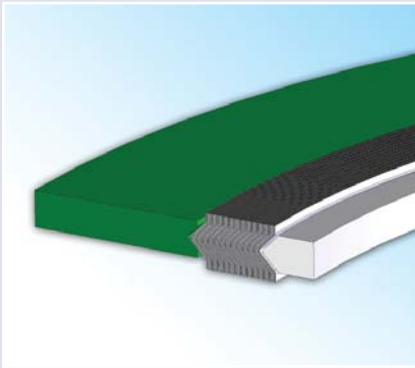

Type CRIR

- Solid metallic inner & outer ring
- Suitable for high pressure and temperature applications
- Standard spiral wound gasket for raised face applications
- Prevents turbulence and erosion damage to flange
- Prevents damage to the gasket bore and inner windings
- Inner ring acts as a heat shield and as a corrosion barrier
- Wide choice of materials for filler and metal strip
- General and critical duties

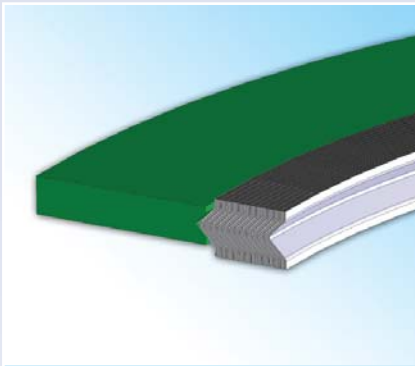

Type CR

- Solid metallic outer ring used as a centering device and compression stop.
- Used mainly on raised face and flat face flanges
- Wide choice of materials for filler and metal strip
- General duties

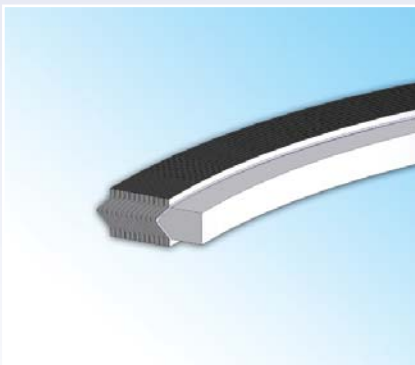

Type RIR

- Solid metallic inner ring
- High pressure & high temperature capability
- Male to female flanges in vessels, valves and pumps
- Wide choice of materials for filler and metal strip
- General and critical duties

Type R

- Wide choice of materials for filler and metallic strip
- Suitable for high pressure and temperature applications
- Recommended flanges - tongue & groove, male to female and flat face to recess in vessels, valves and pumps
- General and critical duties

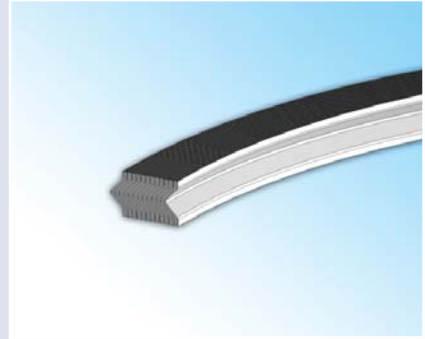

Metallic

Type R Graflex Faced

- Covered with 0.5mm Graflex facings
- Used on manhole covers, vessels, valves and pumps
- Low bolt load applications
- Uneven sealing faces
- Used in tongue & groove, male to female and flat face to recess flanges

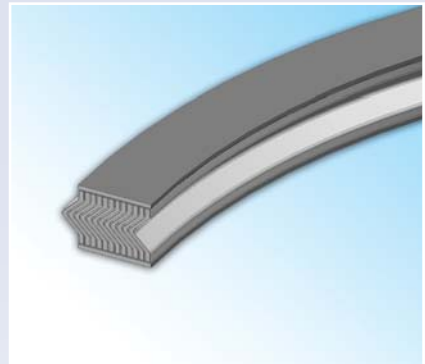

Type HTX (for heat exchanger applications)

- A combination of inner and outer rings
- The inner ring could have pass bars or could carry either a metal clad or soft gasket with pass bars
- Manufactured to customer designs
- Wide choice of materials for filler and metal strip
- Manufactured with thin outer windings to create stable, large diameter gaskets for narrow heat exchanger applications

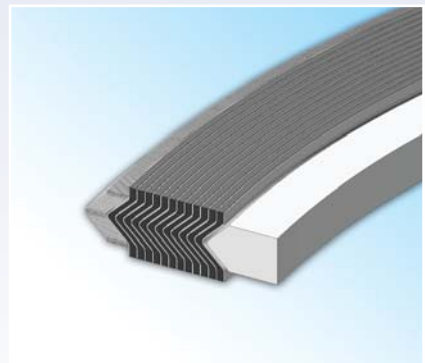



Metallic

Graphite Filled

Applications:

- Used for a wide range of media including steam, oil, hydrocarbons and many chemicals
- Used for applications requiring high integrity sealing performance

Typical Properties:

- High pressure gasket designed for raised face and flat face applications
- Excellent tightness properties even under fluctuating load
- Easy to handle and install
- Inner ring protects windings against media and adds stability at higher pressures and for larger gasket diameters.

Typical Specifications:

Material :	Sealing element :	Graphite/316L
	Centering ring :	Carbon steel
	Inner ring :	316L
Max. temperature :	500°C.	
Max. pressure	>400 bar.	
Suitability	For flanges to:	ASME B16.5, DIN standards, BS 10, JIS standards and custom designs

Winding strip and inner & outer guide rings are available in a wide range of metallic materials shown on page 42.

PTFE Filled

Applications:

- Used for applications demanding outstanding chemical resistance

Typical Properties:

- High integrity gasket designed for raised and flat face applications
- Resistant to virtually all chemicals
- Robust and easy to handle and install
- Inner rings must be used with PTFE sealing material
- Inner ring protects windings against media and adds stability at higher pressures

Typical Specifications:

Material :	Sealing element :	PTFE/316L
	Centering ring :	Carbon steel
	Inner ring :	316L
Max. temperature :	260°C.	
Max. pressure	100 bar.	
Suitability	For flanges to:	ASME B16.5, DIN standards, BS 10, JIS standards and custom designs

Winding strip and inner & outer guide rings are available in a wide range of metallic materials shown on page 42.



Metallic

MAXIFLEX MICA FILLED



Metalllic

Mica Filled

Applications:

- High temperature and high pressure applications

Typical Properties:

- High pressure gasket designed for raised face and flat face applications
- Excellent tightness properties even under fluctuating load
- Easy to handle and install
- Inner ring protects windings against media and adds stability at higher pressures and for larger gasket diameters.

Typical Specifications:

Material :	Sealing element :	Mica/ Inconel 600
	Centering ring :	Inconel 600
	Inner ring :	Inconel 600
Max. temperature :	1000°C.	
Max. pressure	>100 bar.	
Suitability	For flanges to:	ASME B16.5, DIN standards, BS 10, JIS standards and custom designs

Winding strip and inner & outer guide rings are available in a wide range of metallic materials shown on page 42.

MaxiZonal

Applications:

- Used for high temperature applications where high levels of tightness are required

Typical Properties:

- The Klinger MaxiZonal spiral wound gasket combines mica and graphite in one sealing element
- Mica provides excellent thermal properties and protects the graphite from oxidation
- Expanded graphite imparts excellent sealing characteristics
- Unaffected by most chemicals
- Excellent tightness even under fluctuating loads

Typical Specifications:

Material :	Sealing element :	Mica-Graphite-Mica/ Inconel 600
	Centering ring :	Inconel 600
	Inner ring :	Inconel 600
Max. temperature :	900°C.	
Max. pressure	>160 bar.	
Suitability	For flanges to:	ASME B16.5, DIN standards, BS 10, JIS standards and custom designs

Winding strip and inner & outer guide rings are available in a wide range of metallic materials shown on page 42.



Metallic

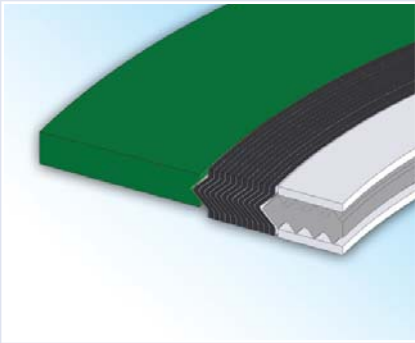

Klinger Maxiflex Pro

A high-integrity, dual-seal gasket specially designed for service in high-criticality, corrosive applications where sealing performance is of paramount importance.

- The Klinger Maxiflex Pro gasket is designed for use in highly aggressive chemical applications such as hydrofluoric acid.
- The inner ring of a standard Maxiflex can allow media to accumulate between the flange and inner ring which could promote corrosion. Maxiflex Pro prevents this, the conformable facing material enables the gasket seal at the flange bore eliminating media build-up.
- The incorporation of a Maxiprofile inner ring creates a gasket with two sealing regions. The Maxiprofile also acts as a compression stop needed for high integrity gaskets and also enables a seal to be created inward of the spiral wound sealing element.

Klinger Maxiflex Pro-X

An addition to the Maxiflex Pro range designed for use in seawater applications where the graphite cannot be exposed to the media.

- The Mica filling on the inner and outer edges of the spiral stops permeation of the seawater to the graphite.
- Designed for a wide range of applications including hydrocarbons, fuels and seawater.
- Fire-safe to API-6FB

Dimensions for Maxiflex Gaskets



MAXIFLEX DIMENSIONS

Dimensions to suit ASME Standard Flanges

Class 150 ASME B16.20 to suit ASME B16.5 flanges

Nominal Size	Dimensions (mm)	Nominal Size	Dimensions (mm)	Nominal Size	Dimensions (mm)
1/2"	48 x 32 x 19 x 14	3 "	137 x 121 x 102 x 81	14 "	451 x 406 x 372 x 349
3/4"	57 x 40 x 25 x 21	4 "	175 x 149 x 127 x 106	16 "	514 x 464 x 422 x 400
1 "	67 x 48 x 32 x 27	5 "	197 x 178 x 156 x 132	18 "	549 x 527 x 475 x 449
1 1/4"	76 x 60 x 48 x 38	6 "	222 x 210 x 183 x 157	20 "	607 x 578 x 526 x 500
1 1/2"	86 x 70 x 54 x 44	8 "	279 x 264 x 233 x 216	24 "	718 x 686 x 629 x 603
2 "	105 x 86 x 70 x 56	10 "	340 x 318 x 287 x 268		
2 1/2"	124 x 99 x 83 x 67	12 "	410 x 375 x 340 x 318		

Class 300 ASME B16.20 to suit ASME B16.5 flanges

Nominal Size	Dimensions (mm)	Nominal Size	Dimensions (mm)	Nominal Size	Dimensions (mm)
1/2"	54 x 32 x 19 x 14	3 "	149 x 121 x 102 x 81	14 "	486 x 406 x 372 x 349
3/4"	67 x 40 x 25 x 21	4 "	181 x 149 x 127 x 106	16 "	540 x 464 x 422 x 400
1 "	73 x 48 x 32 x 27	5 "	216 x 178 x 156 x 132	18 "	597 x 527 x 475 x 449
1 1/4"	83 x 60 x 48 x 38	6 "	251 x 210 x 183 x 157	20 "	654 x 578 x 526 x 500
1 1/2"	95 x 70 x 54 x 44	8 "	308 x 264 x 233 x 216	24 "	775 x 686 x 629 x 603
2 "	111 x 86 x 70 x 56	10 "	362 x 318 x 287 x 268		
2 1/2"	130 x 99 x 83 x 67	12 "	422 x 375 x 340 x 318		

Class 600 ASME B16.20 to suit ASME B16.5 flanges

Nominal Size	Dimensions (mm)	Nominal Size	Dimensions (mm)	Nominal Size	Dimensions (mm)
1/2"	54 x 32 x 19 x 14	3 "	149 x 121 x 102 x 81	14 "	492 x 406 x 362 x 343
3/4"	67 x 40 x 25 x 21	4 "	194 x 149 x 121 x 103	16 "	565 x 464 x 413 x 390
1 "	73 x 48 x 32 x 27	5 "	241 x 178 x 148 x 128	18 "	613 x 527 x 470 x 438
1 1/4"	83 x 60 x 48 x 38	6 "	267 x 210 x 175 x 155	20 "	683 x 578 x 521 x 489
1 1/2"	95 x 70 x 54 x 44	8 "	321 x 264 x 226 x 206	24 "	791 x 686 x 629 x 591
2 "	111 x 86 x 70 x 56	10 "	400 x 318 x 275 x 255		
2 1/2"	130 x 99 x 83 x 67	12 "	457 x 375 x 327 x 307		

Class 900 ASME B16.20 to suit ASME B16.5 flanges

Nominal Size	Dimensions (mm)	Nominal Size	Dimensions (mm)	Nominal Size	Dimensions (mm)
1/2"	64 x 32 x 19 x 14	3 "	168 x 121 x 95 x 79	14 "	521 x 400 x 356 x 321
3/4"	70 x 40 x 25 x 21	4 "	207 x 149 x 121 x 103	16 "	575 x 457 x 413 x 375
1 "	80 x 48 x 32 x 27	5 "	248 x 178 x 148 x 128	18 "	638 x 521 x 464 x 425
1 1/4"	89 x 60 x 40 x 33	6 "	289 x 210 x 175 x 155	20 "	699 x 572 x 521 x 483
1 1/2"	99 x 70 x 48 x 41	8 "	359 x 257 x 222 x 197	24 "	838 x 679 x 629 x 591
2 "	143 x 86 x 59 x 52	10 "	435 x 311 x 276 x 246		
2 1/2"	165 x 99 x 70 x 64	12 "	499 x 368 x 324 x 292		

Class 1500 ASME B16.20 to suit ASME B16.5 flanges

Nominal Size	Dimensions (mm)	Nominal Size	Dimensions (mm)	Nominal Size	Dimensions (mm)
1/2"	64 x 32 x 19 x 14	3 "	175 x 121 x 92 x 79	14 "	578 x 400 x 362 x 321
3/4"	70 x 40 x 25 x 21	4 "	210 x 149 x 118 x 98	16 "	641 x 457 x 406 x 368
1 "	80 x 48 x 32 x 27	5 "	254 x 178 x 143 x 124	18 "	705 x 521 x 464 x 425
1 1/4"	89 x 60 x 40 x 33	6 "	283 x 210 x 171 x 147	20 "	756 x 572 x 514 x 476
1 1/2"	99 x 70 x 48 x 41	8 "	353 x 257 x 216 x 197	24 "	902 x 679 x 616 x 578
2 "	143 x 86 x 59 x 52	10 "	435 x 311 x 267 x 246		
2 1/2"	165 x 99 x 70 x 64	12 "	521 x 368 x 324 x 292		

Class 2500 ASME B16.20 to suit ASME B16.5 flanges

Nominal Size	Dimensions (mm)	Nominal Size	Dimensions (mm)	Nominal Size	Dimensions (mm)
1/2"	70 x 32 x 19 x 14	2 "	146 x 86 x 59 x 52	6 "	318 x 210 x 171 x 147
3/4"	76 x 40 x 25 x 21	2 1/2"	168 x 99 x 70 x 64	8 "	387 x 257 x 216 x 197
1 "	86 x 48 x 32 x 27	3 "	197 x 121 x 92 x 79	10 "	476 x 311 x 270 x 246
1 1/4"	105 x 60 x 40 x 33	4 "	235 x 149 x 118 x 98	12 "	549 x 368 x 318 x 292
1 1/2"	118 x 70 x 48 x 41	5 "	279 x 178 x 143 x 124		

Class 150 ASME B16.20 to suit ASME B16.47 Series A flanges

Nominal Size	Dimensions (mm)	Nominal Size	Dimensions (mm)	Nominal Size	Dimensions (mm)
26"	775 x 705 x 673 x 654	38"	1111 x 1019 x 978 x 959	50"	1435 x 1334 x 1283 x 1264
28"	832 x 756 x 724 x 705	40"	1162 x 1070 x 1029 x 1010	52"	1492 x 1384 x 1334 x 1314
30"	883 x 806 x 775 x 756	42"	1219 x 1124 x 1080 x 1060	54"	1549 x 1435 x 1384 x 1359
32"	940 x 861 x 826 x 806	44"	1276 x 1178 x 1130 x 1111	56"	1607 x 1486 x 1435 x 1410
34"	991 x 911 x 876 x 857	46"	1327 x 1229 x 1181 x 1162	58"	1664 x 1537 x 1486 x 1461
36"	1048 x 969 x 927 x 908	48"	1384 x 1280 x 1232 x 1213	60"	1715 x 1588 x 1537 x 1511

Class 300 ASME B16.20 to suit ASME B16.47 Series A flanges

Nominal Size	Dimensions (mm)	Nominal Size	Dimensions (mm)	Nominal Size	Dimensions (mm)
26"	835 x 737 x 686 x 654	38"	1054 x 1016 x 978 x 953	50"	1378 x 1346 x 1295 x 1245
28"	899 x 787 x 737 x 705	40"	1115 x 1070 x 1022 x 1003	52"	1429 x 1403 x 1346 x 1321
30"	953 x 845 x 794 x 756	42"	1165 x 1121 x 1073 x 1054	54"	1492 x 1454 x 1397 x 1353
32"	1007 x 902 x 851 x 806	44"	1219 x 1181 x 1130 x 1105	56"	1543 x 1505 x 1454 x 1403
34"	1057 x 953 x 902 x 857	46"	1273 x 1229 x 1178 x 1153	58"	1594 x 1562 x 1511 x 1448
36"	1118 x 1007 x 956 x 908	48"	1324 x 1286 x 1235 x 1210	60"	1645 x 1613 x 1562 x 1524

Class 600 ASME B16.20 to suit ASME B16.47 Series A flanges

Nominal Size	Dimensions (mm)	Nominal Size	Dimensions (mm)	Nominal Size	Dimensions (mm)
26"	867 x 737 x 686 x 648	38"	1105 x 1041 x 991 x 953	50"	1448 x 1372 x 1321 x 1270
28"	914 x 787 x 737 x 699	40"	1156 x 1099 x 1048 x 1010	52"	1499 x 1422 x 1372 x 1321
30"	972 x 845 x 794 x 756	42"	1219 x 1156 x 1105 x 1067	54"	1556 x 1480 x 1429 x 1378
32"	1022 x 902 x 851 x 813	44"	1270 x 1213 x 1162 x 1111	56"	1613 x 1530 x 1480 x 1429
34"	1073 x 953 x 902 x 864	46"	1327 x 1264 x 1213 x 1162	58"	1664 x 1588 x 1537 x 1473
36"	1130 x 1007 x 956 x 918	48"	1391 x 1321 x 1270 x 1219	60"	1734 x 1645 x 1594 x 1530

Class 900 ASME B16.20 to suit ASME B16.47 Series A flanges

Nominal Size	Dimensions (mm)	Nominal Size	Dimensions (mm)	Nominal Size	Dimensions (mm)
26"	883 x 737 x 686 x 660	34"	1137 x 953 x 902 x 864	42"	1302 x 1200 x 1149 x 1111
28"	946 x 787 x 737 x 711	36"	1200 x 1010 x 959 x 921	44"	1369 x 1257 x 1207 x 1156
30"	1010 x 845 x 794 x 768	38"	1200 x 1086 x 1035 x 1010	46"	1435 x 1321 x 1270 x 1219
32"	1073 x 902 x 851 x 813	40"	1251 x 1149 x 1099 x 1060	48"	1486 x 1372 x 1321 x 1270

MAXIFLEX DIMENSIONS

Class 150 ASME B16.20 to suit ASME B16.47 Series B flanges

Nominal Size	Dimensions (mm)	Nominal Size	Dimensions (mm)	Nominal Size	Dimensions (mm)
26"	725 x 699 x 673 x 654	38"	1045 x 1010 x 975 x 959	50"	1357 x 1326 x 1283 x 1264
28"	776 x 749 x 724 x 705	40"	1096 x 1064 x 1022 x 1010	52"	1408 x 1376 x 1334 x 1314
30"	827 x 800 x 775 x 756	42"	1146 x 1115 x 1080 x 1060	54"	1464 x 1422 x 1384 x 1365
32"	881 x 851 x 826 x 806	44"	1197 x 1165 x 1124 x 1111	56"	1515 x 1478 x 1445 x 1422
34"	935 x 908 x 876 x 857	46"	1256 x 1224 x 1181 x 1162	58"	1580 x 1529 x 1500 x 1478
36"	988 x 959 x 927 x 908	48"	1307 x 1270 x 1232 x 1213	60"	1630 x 1586 x 1557 x 1535

Class 300 ASME B16.20 to suit ASME B16.47 Series B flanges

Nominal Size	Dimensions (mm)	Nominal Size	Dimensions (mm)	Nominal Size	Dimensions (mm)
26"	772 x 711 x 673 x 654	38"	1099 x 1048 x 1010 x 972	50"	1419 x 1356 x 1318 x 1267
28"	826 x 762 x 724 x 705	40"	1149 x 1099 x 1060 x 1022	52"	1470 x 1407 x 1369 x 1318
30"	886 x 813 x 775 x 756	42"	1200 x 1149 x 1111 x 1086	54"	1530 x 1454 x 1403 x 1365
32"	940 x 864 x 826 x 806	44"	1251 x 1200 x 1162 x 1124	56"	1594 x 1524 x 1480 x 1429
34"	994 x 914 x 876 x 857	46"	1318 x 1254 x 1216 x 1178	58"	1656 x 1573 x 1535 x 1484
36"	1048 x 965 x 927 x 908	48"	1369 x 1311 x 1264 x 1232	60"	1707 x 1630 x 1589 x 1557

Class 600 ASME B16.20 to suit ASME B16.47 Series B flanges

Nominal Size	Dimensions (mm)	Nominal Size	Dimensions (mm)	Nominal Size	Dimensions (mm)
26"	765 x 715 x 664 x 645	38"	1105 x 1041 x 991 x 953	50"	1448 x 1372 x 1321 x 1270
28"	819 x 756 x 705 x 699	40"	1156 x 1099 x 1048 x 1010	52"	1499 x 1422 x 1372 x 1321
30"	880 x 829 x 778 x 753	42"	1219 x 1156 x 1105 x 1067	54"	1556 x 1480 x 1429 x 1378
32"	933 x 883 x 832 x 794	44"	1270 x 1213 x 1162 x 1111	56"	1613 x 1530 x 1480 x 1429
34"	997 x 940 x 889 x 851	46"	1327 x 1264 x 1213 x 1162	58"	1664 x 1588 x 1537 x 1473
36"	1048 x 991 x 940 x 902	48"	1391 x 1321 x 1270 x 1219	60"	1734 x 1645 x 1594 x 1530

Class 900 ASME B16.20 to suit ASME B16.47 Series B flanges

Nominal Size	Dimensions (mm)	Nominal Size	Dimensions (mm)	Nominal Size	Dimensions (mm)
26"	838 x 749 x 705 x 667	34"	1073 x 971 x 921 x 895	42"	1302 x 1200 x 1149 x 1111
28"	902 x 800 x 743 x 718	36"	1124 x 997 x 946 x 921	44"	1369 x 1257 x 1207 x 1156
30"	959 x 857 x 806 x 781	38"	1200 x 1086 x 1035 x 1010	46"	1435 x 1321 x 1270 x 1219
32"	1016 x 914 x 864 x 838	40"	1251 x 1149 x 1099 x 1060	48"	1486 x 1372 x 1321 x 1270

Dimensions to suit DIN Standard Flanges

PN10

Nominal Size	Dimensions (mm)	Nominal Size	Dimensions (mm)	Nominal Size	Dimensions (mm)
10	46 x 36 x 24 x 18	175	247 x 221 x 195 x 183	1200	1341 x 1280 x 1230 x 1210
15	51 x 40 x 28 x 22	200	272 x 251 x 225 x 213	1400	1548 x 1510 x 1450 x 1420
20	61 x 47 x 33 x 27	250	327 x 307 x 286 x 267	1600	1772 x 1720 x 1660 x 1630
25	71 x 54 x 40 x 34	300	377 x 358 x 337 x 318	1800	1972 x 1920 x 1860 x 1830
32	82 x 65 x 49 x 43	350	437 x 405 x 375 x 363	2000	2182 x 2120 x 2050 x 2020
40	92 x 70 x 54 x 48	400	488 x 458 x 426 x 414	2200	2384 x 2330 x 2260 x 2230
50	107 x 84 x 66 x 57	500	593 x 566 x 530 x 518	2400	2594 x 2530 x 2460 x 2430
65	127 x 102 x 82 x 73	600	695 x 666 x 630 x 618	2600	2794 x 2730 x 2660 x 2630
80	142 x 115 x 95 x 86	700	810 x 770 x 730 x 718	2800	3014 x 2930 x 2860 x 2830
100	162 x 140 x 120 x 108	800	917 x 874 x 830 x 818	3000	3228 x 3130 x 3060 x 3030
125	192 x 168 x 146 x 134	900	1017 x 974 x 930 x 910		
150	217 x 196 x 174 x 162	1000	1124 x 1078 x 1030 x 1010		

PN16

Nominal Size	Dimensions (mm)	Nominal Size	Dimensions (mm)	Nominal Size	Dimensions (mm)
10	46 x 36 x 24 x 18	125	192 x 168 x 146 x 134	700	804 x 770 x 730 x 718
15	51 x 40 x 28 x 22	150	217 x 196 x 174 x 162	800	911 x 874 x 830 x 818
20	61 x 47 x 33 x 27	175	247 x 221 x 195 x 183	900	1011 x 974 x 930 x 910
25	71 x 54 x 40 x 34	200	272 x 251 x 225 x 213	1000	1128 x 1078 x 1030 x 1010
32	82 x 65 x 49 x 43	250	328 x 307 x 286 x 267	1200	1342 x 1280 x 1230 x 1210
40	92 x 70 x 54 x 48	300	383 x 358 x 337 x 318	1400	1542 x 1510 x 1450 x 1420
50	107 x 84 x 66 x 57	350	443 x 405 x 375 x 363	1600	1764 x 1720 x 1660 x 1630
65	127 x 102 x 82 x 73	400	495 x 458 x 426 x 414	1800	1964 x 1920 x 1860 x 1830
80	142 x 115 x 95 x 86	500	617 x 566 x 530 x 518	2000	2168 x 2120 x 2050 x 2020
100	162 x 140 x 120 x 108	600	734 x 666 x 630 x 618	2200	2378 x 2330 x 2260 x 2230

PN25

Nominal Size	Dimensions (mm)	Nominal Size	Dimensions (mm)	Nominal Size	Dimensions (mm)
10	46 x 36 x 24 x 18	125	193 x 168 x 146 x 134	700	833 x 770 x 730 x 718
15	51 x 40 x 28 x 22	150	223 x 196 x 174 x 162	800	942 x 874 x 830 x 818
20	61 x 47 x 33 x 27	175	253 x 221 x 195 x 183	900	1042 x 974 x 930 x 910
25	71 x 54 x 40 x 34	200	283 x 251 x 225 x 213	1000	1154 x 1078 x 1030 x 1010
32	82 x 65 x 49 x 43	250	340 x 307 x 286 x 267	1200	1364 x 1280 x 1230 x 1210
40	92 x 70 x 54 x 48	300	400 x 358 x 337 x 318	1400	1578 x 1510 x 1450 x 1420
50	107 x 84 x 66 x 57	350	457 x 405 x 375 x 363	1600	1798 x 1720 x 1660 x 1630
65	127 x 102 x 82 x 73	400	514 x 458 x 426 x 414	1800	2000 x 1920 x 1860 x 1830
80	142 x 115 x 95 x 86	500	624 x 566 x 530 x 518	2000	2230 x 2120 x 2050 x 2020
100	167 x 140 x 120 x 108	600	731 x 666 x 630 x 618		

PN40

Nominal Size	Dimensions (mm)	Nominal Size	Dimensions (mm)	Nominal Size	Dimensions (mm)
10	46 x 36 x 24 x 18	100	167 x 140 x 120 x 108	500	628 x 566 x 530 x 518
15	51 x 40 x 28 x 22	125	193 x 168 x 146 x 134	600	747 x 666 x 630 x 618
20	61 x 47 x 33 x 27	150	223 x 196 x 174 x 162	700	852 x 770 x 730 x 718
25	71 x 54 x 40 x 34	175	265 x 221 x 195 x 183	800	974 x 874 x 830 x 818
32	82 x 65 x 49 x 43	200	290 x 251 x 225 x 213	900	1084 x 974 x 930 x 910
40	92 x 70 x 54 x 48	250	352 x 307 x 286 x 267	1000	1194 x 1078 x 1030 x 1010
50	107 x 84 x 66 x 57	300	417 x 358 x 337 x 318	1200	1398 x 1280 x 1230 x 1210
65	127 x 102 x 82 x 73	350	474 x 405 x 375 x 363	1400	1618 x 1510 x 1450 x 1420
80	142 x 115 x 95 x 86	400	546 x 458 x 426 x 414	1600	1830 x 1720 x 1660 x 1630

MAXIFLEX DIMENSIONS

PN64

Nominal Size	Dimensions (mm)	Nominal Size	Dimensions (mm)	Nominal Size	Dimensions (mm)
10	56 x 36 x 24 x 18	100	173 x 144 x 120 x 108	500	657 x 574 x 530 x 518
15	61 x 40 x 28 x 22	125	210 x 172 x 146 x 134	600	764 x 674 x 630 x 618
20	74 x 47 x 33 x 27	150	247 x 200 x 174 x 162	700	879 x 778 x 730 x 718
25	82 x 54 x 40 x 34	175	277 x 227 x 195 x 183	800	988 x 882 x 830 x 818
32	90 x 65 x 49 x 43	200	309 x 257 x 225 x 213	900	1108 x 982 x 930 x 910
40	102 x 70 x 54 x 48	250	364 x 315 x 286 x 267	1000	1220 x 1086 x 1030 x 1010
50	112 x 84 x 66 x 57	300	424 x 366 x 337 x 318	1200	1452 x 1290 x 1230 x 1210
65	137 x 104 x 82 x 73	350	486 x 413 x 375 x 363		
80	147 x 119 x 95 x 86	400	543 x 466 x 426 x 414		

PN100

Nominal Size	Dimensions (mm)	Nominal Size	Dimensions (mm)	Nominal Size	Dimensions (mm)
10	56 x 36 x 24 x 18	65	143 x 104 x 82 x 73	250	391 x 315 x 286 x 267
15	61 x 40 x 28 x 22	80	153 x 119 x 95 x 86	300	458 x 366 x 337 x 318
20	74 x 47 x 33 x 27	100	180 x 144 x 120 x 108	350	512 x 413 x 375 x 363
25	82 x 54 x 40 x 34	125	217 x 172 x 146 x 134	400	572 x 466 x 426 x 414
32	90 x 65 x 49 x 43	150	257 x 200 x 174 x 162	500	704 x 574 x 530 x 518
40	102 x 70 x 54 x 48	175	287 x 227 x 195 x 183	600	813 x 674 x 630 x 618
50	118 x 84 x 66 x 57	200	324 x 257 x 225 x 213		

PN160

Nominal Size	Dimensions (mm)	Nominal Size	Dimensions (mm)	Nominal Size	Dimensions (mm)
10	56 x 36 x 24 x 18	50	118 x 84 x 66 x 57	175	284 x 227 x 195 x 183
15	61 x 40 x 28 x 22	65	143 x 104 x 82 x 73	200	324 x 257 x 225 x 213
20	74 x 47 x 33 x 27	80	153 x 119 x 95 x 86	250	388 x 315 x 286 x 267
25	82 x 54 x 40 x 34	100	180 x 144 x 120 x 108	300	458 x 366 x 337 x 318
32	90 x 65 x 49 x 43	125	217 x 172 x 146 x 134		
40	102 x 70 x 54 x 48	150	257 x 200 x 174 x 162		

Dimensions to suit BS 10 Standard Flanges

Table D

Nominal Size	Dimensions (mm)	Nominal Size	Dimensions (mm)	Nominal Size	Dimensions (mm)
1/2"	54 x 37 x 26 x 14	5 "	194 x 165 x 149 x 129	16 "	498 x 467 x 445 x 408
3/4"	60 x 43 x 32 x 21	6 "	219 x 191 x 175 x 154	17 "	530 x 498 x 473 x 433
1 "	70 x 52 x 40 x 27	7 "	244 x 219 x 200 x 179	18 "	562 x 524 x 498 x 459
1.1/4"	75 x 60 x 48 x 33	8 "	276 x 244 x 225 x 205	19 "	587 x 549 x 524 x 484
1.1/2"	86 x 67 x 54 x 40	9 "	308 x 270 x 251 x 230	20 "	619 x 575 x 549 x 510
2 "	98 x 79 x 67 x 52	10 "	337 x 295 x 276 x 256	21 "	651 x 603 x 575 x 535
2.1/2"	111 x 98 x 83 x 65	11 "	362 x 321 x 302 x 281	22 "	673 x 629 x 600 x 560
3 "	130 x 113 x 97 x 78	12 "	387 x 349 x 327 x 306	23 "	699 x 654 x 625 x 586
3.1/2"	149 x 125 x 110 x 90	13 "	419 x 391 x 368 x 332	24 "	730 x 679 x 651 x 611
4 "	162 x 140 x 124 x 103	14 "	448 x 416 x 394 x 357		
4.1/2"	175 x 152 x 137 x 116	15 "	473 x 441 x 419 x 383		

Table E

Nominal Size	Dimensions (mm)	Nominal Size	Dimensions (mm)	Nominal Size	Dimensions (mm)
1/2"	54 x 37 x 26 x 14	5 "	194 x 165 x 149 x 129	16 "	498 x 467 x 445 x 408
3/4"	60 x 43 x 32 x 21	6 "	216 x 191 x 175 x 154	17 "	527 x 498 x 473 x 433
1 "	70 x 52 x 40 x 27	7 "	241 x 219 x 200 x 179	18 "	562 x 524 x 498 x 459
1.1/4"	75 x 60 x 48 x 33	8 "	273 x 244 x 225 x 205	19 "	587 x 549 x 524 x 484
1.1/2"	86 x 67 x 54 x 40	9 "	305 x 270 x 251 x 230	20 "	619 x 575 x 549 x 510
2 "	98 x 79 x 67 x 52	10 "	337 x 295 x 276 x 256	21 "	648 x 603 x 575 x 535
2.1/2"	111 x 98 x 83 x 65	11 "	362 x 321 x 302 x 281	22 "	673 x 629 x 600 x 560
3 "	130 x 113 x 97 x 78	12 "	384 x 349 x 327 x 306	23 "	699 x 654 x 625 x 586
3.1/2"	149 x 125 x 110 x 90	13 "	416 x 391 x 368 x 332	24 "	727 x 679 x 651 x 611
4 "	162 x 140 x 124 x 103	14 "	448 x 416 x 394 x 357		
4.1/2"	175 x 152 x 137 x 116	15 "	473 x 441 x 419 x 383		

Table F

Nominal Size	Dimensions (mm)	Nominal Size	Dimensions (mm)	Nominal Size	Dimensions (mm)
1/2"	54 x 39 x 26 x 14	5 "	216 x 171 x 149 x 129	16 "	527 x 476 x 445 x 408
3/4"	60 x 44 x 32 x 21	6 "	241 x 197 x 175 x 154	17 "	559 x 505 x 470 x 433
1 "	71 x 56 x 40 x 27	7 "	273 x 225 x 200 x 179	18 "	581 x 530 x 495 x 459
1.1/4"	83 x 64 x 48 x 33	8 "	305 x 251 x 225 x 205	19 "	613 x 562 x 524 x 484
1.1/2"	89 x 70 x 54 x 40	9 "	333 x 276 x 251 x 230	20 "	645 x 587 x 549 x 510
2 "	111 x 83 x 67 x 52	10 "	359 x 305 x 279 x 256	21 "	670 x 619 x 575 x 535
2.1/2"	130 x 102 x 83 x 65	11 "	384 x 330 x 305 x 281	22 "	695 x 645 x 600 x 560
3 "	149 x 116 x 97 x 78	12 "	416 x 359 x 330 x 306	23 "	724 x 670 x 625 x 586
3.1/2"	162 x 129 x 110 x 90	13 "	445 x 391 x 362 x 332	24 "	749 x 695 x 651 x 611
4 "	175 x 143 x 124 x 103	14 "	470 x 416 x 387 x 357		
4.1/2"	191 x 159 x 137 x 116	15 "	495 x 441 x 413 x 383		

Table H

Nominal Size	Dimensions (mm)	Nominal Size	Dimensions (mm)	Nominal Size	Dimensions (mm)
1/2"	67 x 39 x 26 x 14	5 "	216 x 171 x 149 x 129	16 "	527 x 476 x 445 x 408
3/4"	67 x 44 x 32 x 21	6 "	241 x 197 x 175 x 154	17 "	559 x 505 x 470 x 433
1 "	71 x 56 x 40 x 27	7 "	273 x 225 x 200 x 179	18 "	581 x 530 x 495 x 459
1.1/4"	83 x 64 x 48 x 33	8 "	305 x 251 x 225 x 205	19 "	613 x 562 x 524 x 484
1.1/2"	89 x 70 x 54 x 40	9 "	333 x 276 x 251 x 230	20 "	645 x 587 x 549 x 510
2 "	111 x 83 x 67 x 52	10 "	359 x 305 x 279 x 256	21 "	670 x 619 x 575 x 535
2.1/2"	130 x 102 x 83 x 65	11 "	384 x 330 x 305 x 281	22 "	695 x 645 x 600 x 560
3 "	149 x 116 x 97 x 78	12 "	416 x 359 x 330 x 306	23 "	724 x 670 x 625 x 586
3.1/2"	162 x 129 x 110 x 90	13 "	445 x 391 x 362 x 332	24 "	749 x 695 x 651 x 611
4 "	175 x 143 x 124 x 103	14 "	470 x 416 x 387 x 357		
4.1/2"	191 x 159 x 137 x 116	15 "	495 x 441 x 413 x 383		

Table J

Nominal Size	Dimensions (mm)	Nominal Size	Dimensions (mm)	Nominal Size	Dimensions (mm)
1/2"	67 x 39 x 26 x 14	5 "	213 x 171 x 149 x 129	16 "	524 x 476 x 445 x 408
3/4"	67 x 44 x 32 x 21	6 "	238 x 197 x 175 x 154	17 "	556 x 505 x 470 x 433
1 "	71 x 56 x 40 x 27	7 "	270 x 225 x 200 x 179	18 "	578 x 530 x 495 x 459
1.1/4"	83 x 64 x 48 x 33	8 "	302 x 251 x 225 x 205	19 "	610 x 562 x 524 x 484
1.1/2"	89 x 70 x 54 x 40	9 "	330 x 276 x 251 x 230	20 "	641 x 587 x 549 x 510
2 "	108 x 83 x 67 x 52	10 "	356 x 305 x 279 x 256	21 "	667 x 619 x 575 x 535
2.1/2"	127 x 102 x 83 x 65	11 "	381 x 330 x 305 x 281	22 "	692 x 645 x 600 x 560
3 "	146 x 116 x 97 x 78	12 "	413 x 359 x 330 x 306	23 "	721 x 670 x 625 x 586
3.1/2"	159 x 129 x 110 x 90	13 "	441 x 391 x 362 x 332	24 "	746 x 695 x 651 x 611
4 "	171 x 143 x 124 x 103	14 "	467 x 416 x 387 x 357		
4.1/2"	187 x 159 x 137 x 116	15 "	492 x 441 x 413 x 383		

Table K

Nominal Size	Dimensions (mm)	Nominal Size	Dimensions (mm)	Nominal Size	Dimensions (mm)
1/2"	67 x 39 x 26 x 14	4 "	175 x 143 x 124 x 103	12 "	403 x 359 x 330 x 306
3/4"	67 x 44 x 32 x 21	4.1/2"	187 x 159 x 137 x 116	13 "	451 x 391 x 362 x 332
1 "	79 x 56 x 40 x 27	5 "	213 x 171 x 149 x 129	14 "	476 x 416 x 387 x 357
1.1/4"	83 x 64 x 48 x 33	6 "	238 x 197 x 175 x 154	15 "	508 x 441 x 413 x 383
1.1/2"	95 x 70 x 54 x 40	7 "	267 x 225 x 200 x 179	16 "	533 x 476 x 445 x 408
2 "	111 x 83 x 67 x 52	8 "	292 x 251 x 225 x 205	17 "	565 x 505 x 470 x 433
2.1/2"	127 x 102 x 83 x 65	9 "	330 x 276 x 251 x 230	18 "	619 x 530 x 495 x 459
3 "	146 x 116 x 97 x 78	10 "	356 x 305 x 279 x 256	20 "	673 x 587 x 549 x 510
3.1/2"	162 x 129 x 110 x 90	11 "	384 x 330 x 305 x 281	22 "	730 x 645 x 600 x 560

Table R

Nominal Size	Dimensions (mm)	Nominal Size	Dimensions (mm)	Nominal Size	Dimensions (mm)
1/2"	67 x 39 x 26 x 14	4 "	175 x 143 x 124 x 103	12 "	429 x 359 x 330 x 306
3/4"	67 x 44 x 32 x 21	4.1/2"	187 x 159 x 137 x 116	13 "	464 x 391 x 362 x 332
1 "	79 x 56 x 40 x 27	5 "	213 x 171 x 149 x 129	14 "	495 x 416 x 387 x 357
1.1/2"	95 x 70 x 54 x 40	6 "	238 x 197 x 175 x 154	15 "	521 x 441 x 413 x 383
1.1/4"	83 x 64 x 48 x 33	7 "	267 x 225 x 200 x 179	16 "	552 x 476 x 445 x 408
2 "	111 x 83 x 67 x 52	8 "	298 x 251 x 225 x 205	17 "	578 x 505 x 470 x 433
2.1/2"	127 x 102 x 83 x 65	9 "	330 x 276 x 251 x 230	18 "	638 x 530 x 495 x 459
3 "	146 x 116 x 97 x 78	10 "	362 x 305 x 279 x 256	20 "	692 x 587 x 549 x 510
3.1/2"	162 x 129 x 110 x 90	11 "	403 x 330 x 305 x 281	22 "	756 x 645 x 600 x 560

Table S

Nominal Size	Dimensions (mm)	Nominal Size	Dimensions (mm)	Nominal Size	Dimensions (mm)
1/2"	70 x 32 x 19	3.1/2"	168 x 121 x 98	10 "	394 x 302 x 267
3/4"	70 x 40 x 25	4 "	178 x 137 x 111	11 "	435 x 327 x 292
1 "	83 x 48 x 32	4.1/2"	191 x 149 x 124	12 "	470 x 356 x 321
1.1/4"	89 x 56 x 38	5 "	213 x 162 x 137	13 "	502 x 384 x 346
1.1/2"	102 x 64 x 44	6 "	248 x 187 x 162	14 "	540 x 410 x 371
2 "	114 x 79 x 57	7 "	289 x 219 x 187	15 "	581 x 438 x 400
2.1/2"	127 x 95 x 73	8 "	324 x 244 x 213	16 "	616 x 467 x 425
3 "	143 x 108 x 86	9 "	359 x 273 x 241		

Table T

Nominal Size	Dimensions (mm)	Nominal Size	Dimensions (mm)	Nominal Size	Dimensions (mm)
1/2"	83 x 32 x 19	3 "	165 x 114 x 89	8 "	368 x 254 x 216
3/4"	83 x 40 x 25	3.1/2"	187 x 130 x 102	9 "	410 x 286 x 244
1 "	89 x 48 x 32	4 "	206 x 143 x 114	10 "	451 x 311 x 270
1.1/4"	98 x 59 x 41	4.1/2"	229 x 159 x 127	11 "	489 x 337 x 295
1.1/2"	114 x 67 x 48	5 "	244 x 171 x 140	12 "	527 x 368 x 324
2 "	127 x 83 x 60	6 "	286 x 197 x 165	13 "	559 x 394 x 349
2.1/2"	143 x 98 x 76	7 "	333 x 229 x 191		

Note: If inner guide rings are required for Table S and T flanges then special dimensions are required.

Metallic

Maxiprofile



MAXIPROFILE

The Klinger Maxiprofile is a composite gasket which utilises a serrated metal core with a soft facing material. The metal core is machined on each contact face with concentric serrations which provide high pressure areas, ensuring that the soft coating flows into any imperfections in the flange even at relatively low bolt loads. The soft facing material is engineered to compress in to the serrations on the core and form a thin film across the peaks creating the ideal sealing density in the grooves of the profile. The result is a gasket which combines the benefits of soft cut materials with the advantages of seal integrity associated with metallic gaskets.

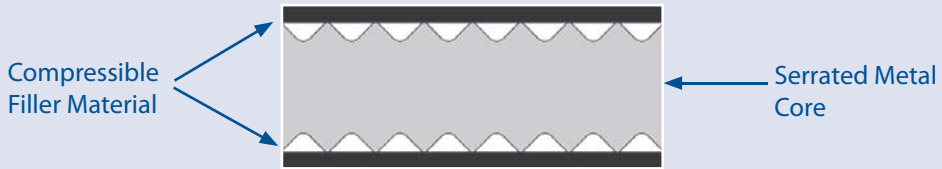

Expanded graphite is the most common facing material used for Maxiprofile gaskets. However, other materials can be used, such as PTFE for chemically aggressive duties or mica for high temperature service.

Facing Material	Maximum Temperature
Graphite	550°C
PTFE	260°C
Mica	1000°C
KLINGERSIL® C-4430	250°C

Maxiprofile gaskets can also be manufactured from a range of core materials according to media compatibility and temperature considerations.

Core Material	Maximum Temperature
316L Stainless Steel	800°C
304 Stainless Steel	550°C
Duplex UN S31803	800°C
347 Stainless Steel	800°C
321 Stainless Steel	800°C
Monel 400	450°C
Nickel 200	315°C
Titanium Gr 2	350°C
Hastelloy B-2/B-3	450°C
Hastelloy C-276	450°C

Core Material	Maximum Temperature
Inconel 600	1000°C
Inconel 625	450°C
Incoloy 825	450°C
Zirconium	500°C
Super Duplex	600°C
254 SMO	600°C
Titanium Gr7	350°C
Hastelloy C-22	450°C
Hastelloy G-31	450°C
Alloy 20	600°C

General Properties of Maxiprofile Gaskets:

- A wide range of seating stresses under which the seal is effected and maintained
- Can be used when there is insufficient bolt load to seal conventional gasket materials
- Easy to handle and fit
- Suitable for a wide range of operating conditions
- The soft facing layer prevents damage to the mating flange
- Sealing is not sensitive to uneven bolt loading conditions
- Can be refurbished with a new facing layer and reused

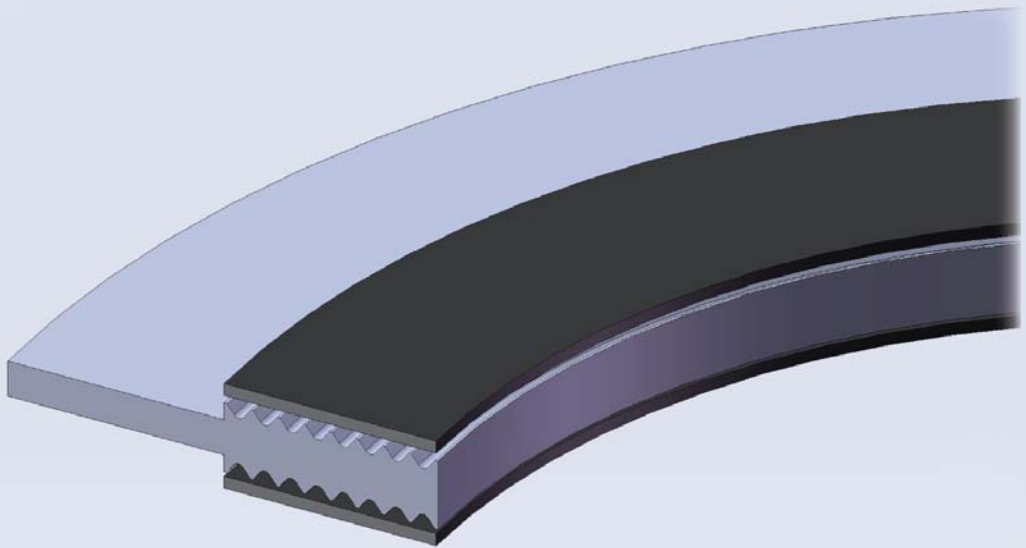

Metallic

Applications of Maxiprofile Gaskets:

- Heat exchanger and vessel applications
- High and low temperatures
- Pressures of up to 250 bar
- Low bolt loads
- Narrow flange widths
- Damaged flanges

Core Design

Standard core design is parallel which offers the advantage of even stress distribution across the gasket face. Convex Maxiprofiles are also available which have a reduced depth of grooves towards the profile centre. This type of profile ensures a high seating stress in the middle of the profile and is effective for low bolt load applications.

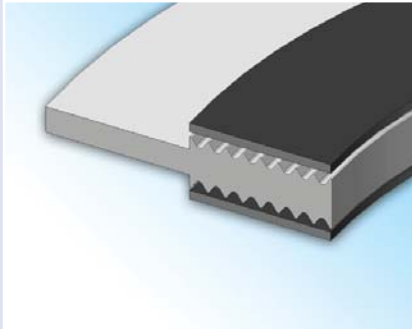

Maxiprofile LA 1



Maxiprofile LA 2

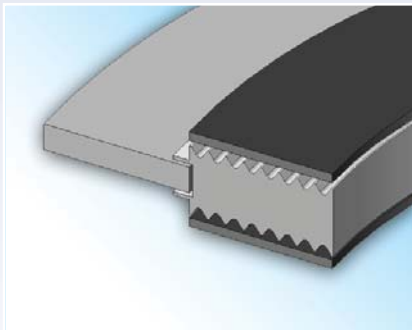

Maxiprofile LA 3

Klinger Maxiprofile Type 109

Applications:

- Used for a wide range of applications including steam, oil , hydrocarbons and can also be tailored to suit more aggressive chemicals
- Used for applications requiring a high-integrity seal such as chlorine
- Especially suited to use in heat exchangers

Typical Properties:

- High pressure gasket with a wide seating stress range
- Excellent tightness even at low bolt loads
- Reusable metallic core can be refaced after service
- Available facings include:
- Graphite, PTFE, KLINGERSIL and Soft-chem

Typical Specifications:

Core material :	316L - 3.0, 4.0, 5.0mm	
Facing material:	Graphite - 0.5mm	
Facing density:	1 g/cm ³ (alternative 0.7g/cm ³)	
Max. temperature :	550°C	
Max. pressure	>400 bar	
Suitability	For flanges to:	ASME B16.5, DIN standards, BS 10, JIS standards and custom designs

Style:	Description:
LA 1	Used for standard pipework. Lateral profiled joint with guide ring for raised and flat face applications
LA 2	Used for vessels and heat exchangers. Lateral profiled joint without guide ring for male and female, tongue and groove and grooved flanges
LA 3	Used for large diameter standard pipework. Lateral profiled joint with floating guide ring for raised and flat face applications
CA1, 2 & 3	Convex profiled joints in the same style as LA 1, 2 and 3. The convex profile is designed to assist sealing in low bolt load applications

Metallic cores are available in a wide range of metallic materials shown on page 62.

Klinger Maxitherm

Applications:

- Designed for use at high temperatures and to create a seal at low bolt loads.
- Especially suited to use in heat exchangers

Typical Properties:

- High pressure gasket with a wide seating stress range
- Excellent tightness even at low bolt loads
- Reusable metallic core can be refaced with mica after service

Typical Specifications:

Core material :	Inconel 600 - 3.0, 4.0 or 5.0mm	
Facing material:	Mica - 0.5mm	
Facing density:	1 g/cm ³ (alternative 0.7g/cm ³)	
Max. temperature :	900°C	
Max. pressure	>40 bar	
Suitability	For flanges to:	ASME B16.5, DIN standards, BS 10, JIS standards and custom designs

Style:	Description:
LA 1	Used for standard pipework. Lateral profiled joint with guide ring for raised and flat face applications
LA 2	Used for vessels and heat exchangers. Lateral profiled joint without guide ring for male and female, tongue and groove and grooved flanges
LA 3	Used for large diameter standard pipework. Lateral profiled joint with floating guide ring for raised and flat face applications
CA1, 2 & 3	Convex profiled joints in the same style as LA 1, 2 and 3. The convex profile is designed to assist sealing in low bolt load applications.

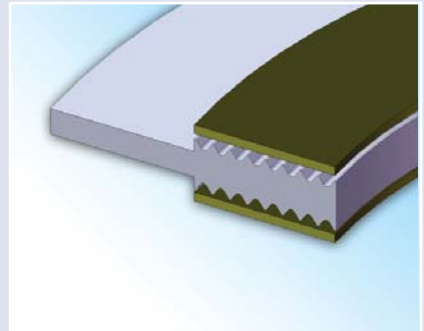

Maxitherm LA 1

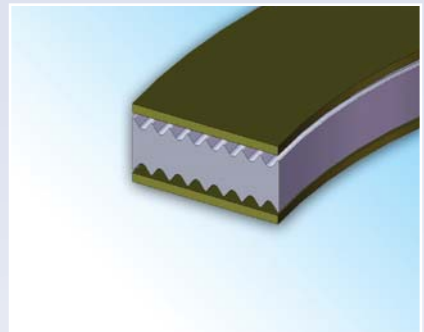

Maxitherm LA 2

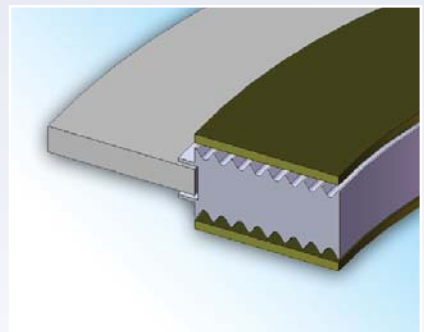

Maxitherm LA 3

Metallic cores are available in a wide range of materials shown on page 62.

Dimensions for Maxiprofile Gaskets



MAXIPROFILE DIMENSIONS

Dimensions to suit ASME Standard Flanges

Class 150 to suit ASME B16.5 flanges

Nominal Size	Dimensions (mm)	Nominal Size	Dimensions (mm)	Nominal Size	Dimensions (mm)
1/2"	48 x 33 x 23	3 "	137 x 124 x 98	14 "	451 x 410 x 372
3/4"	57 x 40 x 29	4 "	175 x 154 x 124	16 "	514 x 467 x 422
1 "	67 x 48 x 37	5 "	197 x 183 x 151	18 "	549 x 530 x 479
1 1/4"	76 x 60 x 44	6 "	222 x 213 x 178	20 "	606 x 581 x 530
1 1/2"	86 x 70 x 52	8 "	279 x 267 x 229	24 "	718 x 683 x 632
2 "	105 x 89 x 70	10 "	340 x 321 x 283		
2 1/2"	124 x 102 x 83	12 "	410 x 378 x 340		

Class 300 to suit ASME B16.5 flanges

Nominal Size	Dimensions (mm)	Nominal Size	Dimensions (mm)	Nominal Size	Dimensions (mm)
1/2"	54 x 33 x 23	3 "	149 x 124 x 98	14 "	486 x 410 x 372
3/4"	67 x 40 x 29	4 "	181 x 154 x 124	16 "	540 x 467 x 422
1 "	73 x 48 x 37	5 "	216 x 183 x 151	18 "	597 x 530 x 479
1 1/4"	83 x 60 x 44	6 "	251 x 213 x 178	20 "	654 x 581 x 530
1 1/2"	95 x 70 x 52	8 "	308 x 267 x 229	24 "	775 x 683 x 632
2 "	111 x 89 x 70	10 "	362 x 321 x 283		
2 1/2"	130 x 102 x 83	12 "	422 x 378 x 340		

Class 600 to suit ASME B16.5 flanges

Nominal Size	Dimensions (mm)	Nominal Size	Dimensions (mm)	Nominal Size	Dimensions (mm)
1/2"	54 x 33 x 23	3 "	149 x 124 x 98	14 "	492 x 410 x 372
3/4"	67 x 40 x 29	4 "	194 x 154 x 124	16 "	565 x 467 x 422
1 "	73 x 48 x 37	5 "	241 x 183 x 151	18 "	613 x 530 x 479
1 1/4"	83 x 60 x 44	6 "	267 x 213 x 178	20 "	683 x 581 x 530
1 1/2"	95 x 70 x 52	8 "	321 x 267 x 229	24 "	791 x 683 x 632
2 "	111 x 89 x 70	10 "	400 x 321 x 283		
2 1/2"	130 x 102 x 83	12 "	457 x 378 x 340		

Class 900 to suit ASME B16.5 flanges

Nominal Size	Dimensions (mm)	Nominal Size	Dimensions (mm)	Nominal Size	Dimensions (mm)
1/2"	64 x 33 x 23	3 "	168 x 124 x 98	14 "	521 x 410 x 372
3/4"	70 x 40 x 29	4 "	206 x 154 x 124	16 "	575 x 467 x 422
1 "	79 x 48 x 37	5 "	248 x 183 x 151	18 "	638 x 530 x 479
1 1/4"	89 x 60 x 44	6 "	289 x 213 x 178	20 "	699 x 581 x 530
1 1/2"	98 x 70 x 52	8 "	359 x 267 x 229	24 "	838 x 683 x 632
2 "	143 x 89 x 70	10 "	435 x 321 x 283		
2 1/2"	165 x 102 x 83	12 "	498 x 378 x 340		

Class 1500 to suit ASME B16.5 flanges

Nominal Size	Dimensions (mm)	Nominal Size	Dimensions (mm)	Nominal Size	Dimensions (mm)
1/2"	64 x 33 x 23	3 "	175 x 124 x 98	14 "	578 x 410 x 372
3/4"	70 x 40 x 29	4 "	210 x 154 x 124	16 "	641 x 467 x 422
1 "	79 x 48 x 37	5 "	254 x 183 x 151	18 "	705 x 530 x 479
1 1/4"	89 x 60 x 44	6 "	283 x 213 x 178	20 "	756 x 581 x 530
1 1/2"	98 x 70 x 52	8 "	352 x 267 x 229	24 "	902 x 683 x 632
2 "	143 x 89 x 70	10 "	435 x 321 x 283		
2 1/2"	165 x 102 x 83	12 "	521 x 378 x 340		

Dimensions to suit ASME Standard Flanges

Class 2500 to suit ASME B16.5 flanges

Nominal Size	Dimensions (mm)	Nominal Size	Dimensions (mm)	Nominal Size	Dimensions (mm)
1/2"	70 x 33 x 23	2 "	146 x 89 x 70	6 "	318 x 213 x 178
3/4"	76 x 40 x 29	2.1/2"	168 x 102 x 83	8 "	387 x 267 x 229
1 "	86 x 48 x 37	3 "	197 x 124 x 98	10 "	476 x 321 x 283
1.1/4"	105 x 60 x 44	4 "	235 x 154 x 124	12 "	550 x 378 x 340
1.1/2"	118 x 70 x 52	5 "	279 x 183 x 151		

Dimensions to suit DIN standard flanges

PN10

Nominal Size	Dimensions (mm)	Nominal Size	Dimensions (mm)	Nominal Size	Dimensions (mm)
10	46 x 36 x 22	65	127 x 100 x 81	300	377 x 340 x 320
15	51 x 42 x 26	80	142 x 115 x 95	350	437 x 395 x 375
20	61 x 47 x 31	100	162 x 138 x 118	400	488 x 450 x 426
25	71 x 52 x 36	125	192 x 162 x 142	500	593 x 560 x 530
32	82 x 62 x 46	150	217 x 190 x 170	600	695 x 664 x 630
40	92 x 69 x 53	200	272 x 240 x 220		
50	107 x 81 x 65	250	327 x 290 x 270		

PN16

Nominal Size	Dimensions (mm)	Nominal Size	Dimensions (mm)	Nominal Size	Dimensions (mm)
10	46 x 36 x 22	65	127 x 100 x 81	300	383 x 340 x 320
15	51 x 42 x 26	80	142 x 115 x 95	350	443 x 395 x 375
20	61 x 47 x 31	100	162 x 138 x 118	400	495 x 450 x 426
25	71 x 52 x 36	125	192 x 162 x 142	500	617 x 560 x 530
32	82 x 62 x 46	150	217 x 190 x 170	600	734 x 664 x 630
40	92 x 69 x 53	200	272 x 240 x 220		
50	107 x 81 x 65	250	328 x 290 x 270		

PN25

Nominal Size	Dimensions (mm)	Nominal Size	Dimensions (mm)	Nominal Size	Dimensions (mm)
10	46 x 36 x 22	65	127 x 100 x 81	300	400 x 340 x 320
15	51 x 42 x 26	80	142 x 115 x 95	350	457 x 395 x 375
20	61 x 47 x 31	100	167 x 138 x 118	400	514 x 450 x 426
25	71 x 52 x 36	125	193 x 162 x 142	500	624 x 560 x 530
32	82 x 62 x 46	150	223 x 190 x 170	600	731 x 664 x 630
40	92 x 69 x 53	200	283 x 240 x 220		
50	107 x 81 x 65	250	340 x 290 x 270		

PN40

Nominal Size	Dimensions (mm)	Nominal Size	Dimensions (mm)	Nominal Size	Dimensions (mm)
10	46 x 36 x 22	65	127 x 100 x 81	300	417 x 340 x 320
15	51 x 42 x 26	80	142 x 115 x 95	350	474 x 395 x 375
20	61 x 47 x 31	100	168 x 138 x 118	400	546 x 450 x 426
25	71 x 52 x 36	125	193 x 162 x 142	500	628 x 560 x 530
32	82 x 62 x 46	150	223 x 190 x 170	600	747 x 664 x 630
40	92 x 69 x 53	200	290 x 240 x 220		
50	107 x 81 x 65	250	352 x 290 x 270		

MAXIPROFILE DIMENSIONS

Dimensions to suit DIN standard flanges

PN64

Nominal Size	Dimensions (mm)	Nominal Size	Dimensions (mm)	Nominal Size	Dimensions (mm)
10	56 x 36 x 22	65	137 x 100 x 81	300	424 x 356 x 320
15	61 x 42 x 26	80	147 x 115 x 95	350	486 x 415 x 375
20	74 x 47 x 31	100	162 x 138 x 118	400	543 x 474 x 426
25	82 x 52 x 36	125	210 x 162 x 142	500	657 x 588 x 530
32	90 x 62 x 46	150	247 x 190 x 170	600	764 x 700 x 630
40	102 x 69 x 53	200	309 x 248 x 220		
50	112 x 81 x 65	250	364 x 300 x 270		

PN100

Nominal Size	Dimensions (mm)	Nominal Size	Dimensions (mm)	Nominal Size	Dimensions (mm)
10	56 x 36 x 22	40	102 x 69 x 53	125	217 x 162 x 142
15	61 x 42 x 26	50	118 x 81 x 65	150	257 x 190 x 170
20	74 x 47 x 31	65	143 x 100 x 81	200	324 x 248 x 220
25	82 x 52 x 36	80	153 x 115 x 95	250	391 x 300 x 270
32	90 x 62 x 46	100	180 x 138 x 118	300	458 x 356 x 320

PN160

Nominal Size	Dimensions (mm)	Nominal Size	Dimensions (mm)	Nominal Size	Dimensions (mm)
10	56 x 36 x 22	40	102 x 69 x 53	125	217 x 162 x 142
15	61 x 42 x 26	50	118 x 81 x 65	150	257 x 190 x 170
20	74 x 47 x 31	65	143 x 100 x 81	200	324 x 248 x 220
25	82 x 52 x 36	80	153 x 115 x 95		
32	90 x 62 x 46	100	180 x 138 x 118		

PN250

Nominal Size	Dimensions (mm)	Nominal Size	Dimensions (mm)	Nominal Size	Dimensions (mm)
10	67 x 36 x 22	25	82 x 52 x 36	50	123 x 87 x 65
15	72 x 42 x 26	32	100 x 66 x 46		
20	79 x 47 x 31	40	108 x 73 x 53		

Fire Safe Corrosion Control gasket (FSCCG)

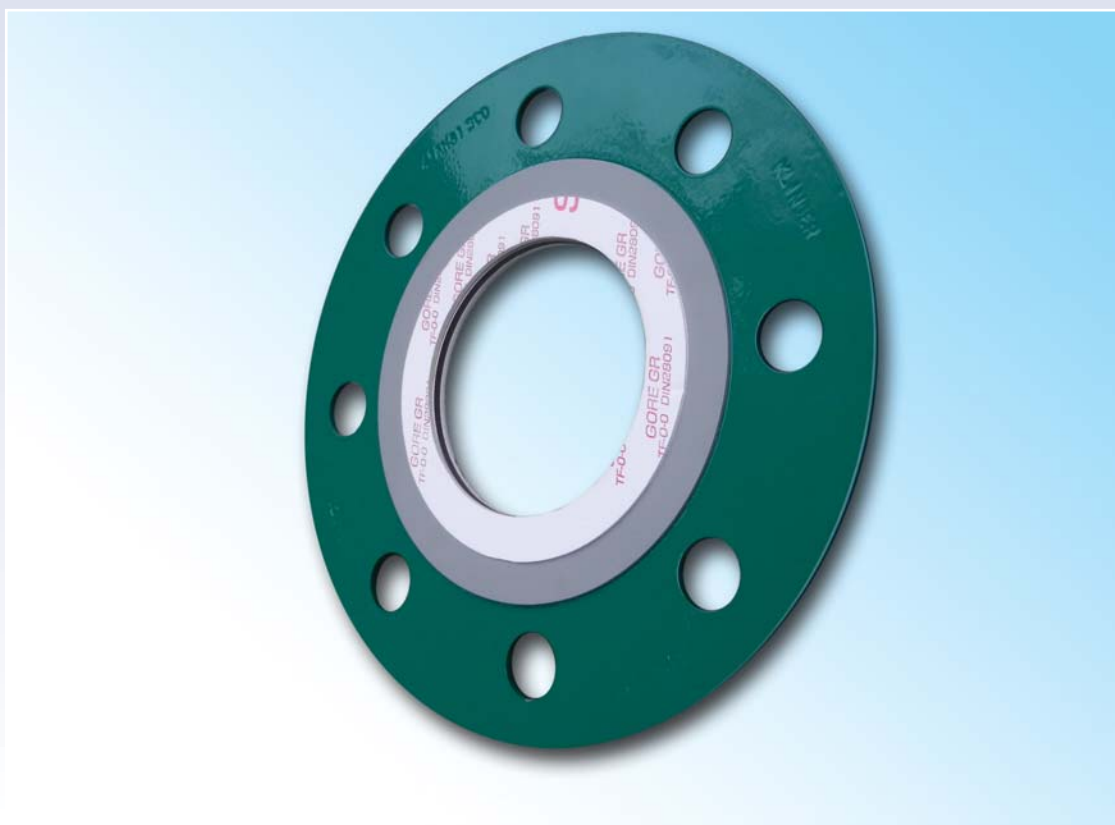

FIRE-SAFE CORROSION CONTROL

Cut Corrosion, Cut Costs

The oil and gas industry is well aware of the vital importance of corrosion control across the life cycle of every asset.

That is why Klinger Ltd has developed the unique Fire Safe Corrosion Control Gasket (FSCCG)

Simple to install, the FSCCG limits further corrosion, giving asset managers and engineers essential quality assurance and cost savings.

Regular corrosion inspection activities can be completed with the knowledge that joints can be remade even if corroded flanges are evident. This is facilitated with Klinger FSCCG without the need for expensive and disruptive flange replacement or machining.

The risk of leaks is reduced, minimising the environmental impact of any installation.

Halts in production are also reduced, avoiding major loss of revenue.



Installation

The FSCCG is installed like any other gasket; simply remove any loose debris from the flange surface with a wire brush before fitting the gasket. The full-face design ensures the gasket is located correctly.

Dual Sealing Technology

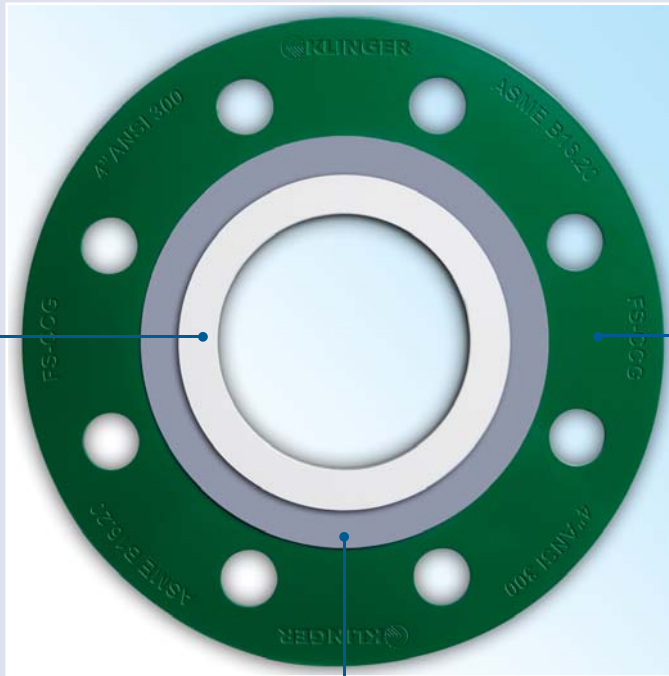

Metallic

GORE™ GR
(Primary seal)

Highly conformable GORE™ GR multidirectional ePTFE is designed to flow into the damaged flange creating a seal and limiting further corrosion. Klinger's active partner Gore Sealant Technologies has developed a specialist range of PTFE products over the last 50 years to meet the stringent demands of the Petrochemical Industry.

KLINGER®top-chem 2000
(Secondary seal)

Premium grade modified PTFE KLINGER® Top-Chem 2000 which uniquely holds fire-safe approval to API 6FA, is bound to the precision profiled metal core, conveying excellent blow out resistance. KLINGER® Top-Chem-2000 is also creep resistant minimising any stress reduction over the lifetime of the joint.

Metal Core

The gasket incorporates a high-strength metallic core which increases resistance to blow out and helps create a stable high-integrity joint which is robust, easy to handle and install. The epoxy coated full-face metallic core ensures the gasket is centrally located with the flange and the coating provides resistance to corrosion necessary for offshore applications.

Semi-Metallic Gaskets



SEMI-METALLIC GASKETS

Metal Jacketed Gaskets

Metal Jacketed gaskets are the most basic type of semi-metallic gaskets combining the high pressure suitability and blow out resistance of metallic materials with the improved compressibility of soft materials. Metal jacketed gaskets offer an economical seal where sealing faces are narrow and can be produced in a variety of shapes, making them a good option for heat exchanger jointing.

Corrugated gaskets are a highly versatile family of products, available in wide variety of configurations and suited to a wide range of applications. For improved sealing performance the gaskets can be partially or completely covered.

General Properties

- Economical
- Easy to handle and install
- Suitable for high temperatures
- Suitable for narrow flanges
- Good blow-out resistance

Applications

- Heat exchangers
- Exhaust gases
- Valve bonnet gaskets
- Narrow flanges

Metal Jacketed and corrugated gaskets can be manufactured to suit a range of chemical environments by the selection of a suitable alloy jacket or core. The following materials are available:

Types of Metal Jacketed Gaskets

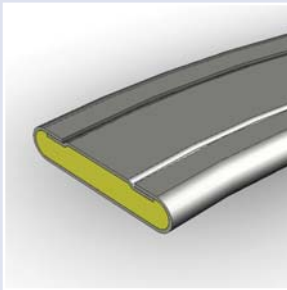

Double Jacketed

Constructed of soft filler encapsulated by a metal jacket and insert. Designed for use on high temperature and pressure applications

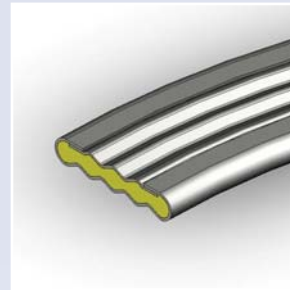

Double Jacketed Corrugated (Soft Filler)

The reduced contact area of the construction enhances compressive characteristics making it more suited to applications of lower bolt load or where flanges are uneven.

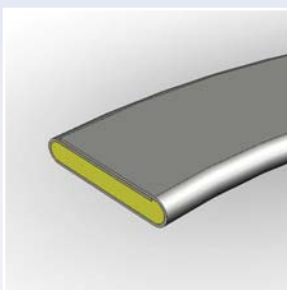

Single Jacketed Fully Enclosed

Constructed of soft filler completely enclosed in a single jacket for use in applications where the width does not permit the use of a double jacketed gasket.



Klinger Maxigraph Corrugated steel with Soft Facing Layer

Comprises a single corrugated core faced with either PTFE or Graphite dependant on application. The soft facing layer provides the gasket with a high level of tightness while the core gives the gasket both resilience and integrity. Used in variety of applications including heat exchangers, valve bonnet application and small recess gaps.

Other styles are available

Klinger Double Jacketed Type 100**Applications:**

- Used for boilers and heat exchangers, suitable for narrow sealing faces.

Typical Properties:

- Economical, basic with added strength from metallic jacket
- Metal jacket provides increased gasket stability and blow-out resistance
- Chemical resistance to a wide range of media can be accommodated by selection of a suitable metal

Typical Specifications:

Standard materials :	Soft Iron / high temperature millboard
Max. temperature :	400°C
Max. pressure	100 bar
Thickness:	3.0mm (standard)

Availability:

Can be manufactured from a range of jacket materials



Metallic

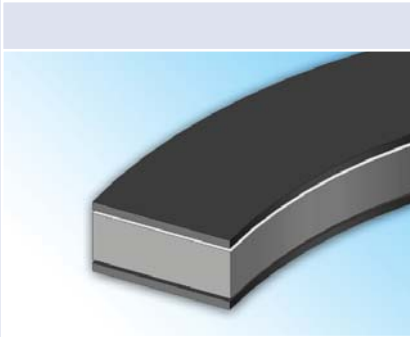

Klinger Type 108

Applications:

- Used for boilers and heat exchangers, suitable for narrow sealing faces
- Used to create a more stable gasket than laminated graphite materials for large applications

Typical Properties:

- Economical alternative to Maxiprofile gaskets for lower pressure, lower criticality applications
- Medium pressure gasket with a wide seating stress range
- Excellent tightness at low bolt loads

Typical Specifications:

Material :	316L / Graphite
Max. temperature :	450°C
Max. pressure	100 bar
Thickness:	Core: 3.0mm (standard)
	Facing: 0.5mm

Availability:

Can be manufactured from a range of core materials

Klinger Maxigraph**Applications:**

- Vessel applications with narrow seating widths
- Pipeline applications
- Suitable for a wide range of application temperatures

Typical Properties:

- Corrugated metallic core provides the gasket with improved handling characteristics over graphite laminates
- Corrugations on the core create high stress regions to allow excellent sealing properties even with low gasket loads
- Provides greater recovery properties than graphite laminate gaskets

Typical Specifications:

Material :	316 / Graphite
Max. temperature :	450°C
Max. pressure	100 bar
Thickness:	2.5mm (standard)

Availability:

Can be manufactured from a range of metallic materials including:

Stainless steel 304	Incoloy 800, 825
Stainless steel 904	Hastelloy C-276
Inconel 600, 625	Monel 400

Can be manufactured with PTFE facing; Klinger Maxiflon

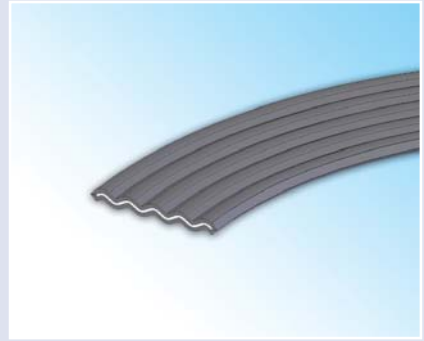

Metallic Ring Joints



METALLIC RING JOINTS

Metallic ring joint gaskets are heavy duty, high-pressure gaskets largely used in offshore petrochemical applications. They are precision-engineered components designed to be used in conjunction with precision-machined flanges. Our Ring Joints are manufactured according to ASME B16.20 or API 6A.

The gasket material is selected on a number of grounds; primarily chemical compatibility with the media and the hardness of the flange. The gasket material ideally needs to be roughly 30 Brinell less than the flange material to ensure sufficient deformation of the gasket without damaging the flange facing.

A number of ring joint styles are available designed for specific flange types, these are:

Type	Nominal Pipe Size	Class Ratings
Type R Oval and Octagonal	1/2" to 24" 26" to 36" 1 1/2" to 20"	300 to 900 ASME B16.20 Series A 150 to 2500 ASME B16.20 API 6A
Type RX	1 1/2" to 24" 26" to 36" 1 1/2" to 20"	720 to 5000 ASME B16.20 300 to 900 ASME B16.20 Series A API 6A
Type BX	1 11/16" to 21 1/4"	5000 to 20000 ASME B16.20

Common Materials

Material	Standard RTJ Hardness (Brinell)	Temperature Limitation	Identification
Soft iron	90	-60 to +400°C	D
Low carbon steel	120	-40 to +500°C	S
4%-6% Cr 1/2% Mo: F5	130	-125 to +500°C	F5
Stainless steel 304	160	-250 to +550°C	S304
Stainless steel 316	160	-110 to +600°C	S316
Stainless steel 321	160	-250 to +800°C	S321
Stainless steel 347	160	-250 to +800°C	S347
Stainless steel 410	170	-20 to +500°C	S410
Inconel 625	-	450°C	625
Incoloy 825	-	450°C	825
Hastelloy C-276	-	450°C	C-276
Duplex	-	800°C	S31803
Titanium	-	350°C	TI



Klinger Type R Oval

Applications:

- Used for high pressure applications.

Typical Properties:

- High integrity seal at high pressures
- Suitable for flat and round bottom groove flanges

Typical Specifications:

Material :	Soft Iron
Max. temperature :	400°C
Max. pressure:	Up to Class 2500

Availability:

Manufactured to ASME B16.20 or API 6A
 Also available in a range of alloys shown on page 82.

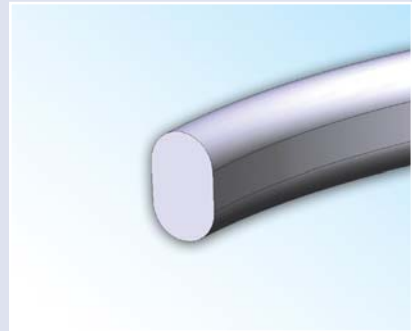

Metallc

Type R Oval RTJ Dimensions to ASME B16.20

Ring Number	Nominal Size	Class	Pitch Diameter	Width	Height
R-11	1/2"	300, 600	1.344	0.250	0.440
R-12	1/2"	900, 1500	1.563	0.313	0.560
R-13	3/4"	300, 600	1.688	0.313	0.560
R-13	1/2"	2500	1.688	0.313	0.560
R-14	3/4"	900, 1500	1.750	0.313	0.560
R-15	1 "	150	1.875	0.313	0.560
R-16	1 "	300, 600, 900, 1500	2.000	0.313	0.560
R-16	3/4"	2500	2.000	0.313	0.560
R-17	1.1/4"	150	2.250	0.313	0.560
R-18	1.1/4"	300, 600, 900, 1500	2.375	0.313	0.560
R-18	1 "	2500	2.375	0.313	0.560
R-19	1.1/2"	150	2.563	0.313	0.560
R-20	1.1/2"	300, 600, 900, 1500	2.688	0.313	0.560
R-21	1.1/4"	2500	2.844	0.438	0.690
R-22	2 "	150	3.250	0.313	0.560
R-23	2 "	300, 600	3.250	0.438	0.690
R-23	1.1/2"	2500	3.250	0.438	0.690
R-24	2 "	900, 1500	3.750	0.438	0.690
R-25	2.1/2"	150	4.000	0.313	0.560
R-26	2.1/2"	300, 600	4.000	0.438	0.690
R-26	2 "	2500	4.000	0.438	0.690
R-27	2.1/2"	900, 1500	4.250	0.438	0.690
R-28	2.1/2"	2500	4.375	0.500	0.750
R-29	3 "	150	4.500	0.313	0.560
R-30	3"(1)	300	4.625	0.438	0.690

All dimensions in Inches

METALLIC RING JOINTS

Type R Oval RTJ Dimensions to ASME B16.20

Ring Number	Nominal Size	Class	Pitch Diameter	Width	Height
R-31	3 "	300, 600, 900	4.875	0.438	0.690
R-32	3 "	2500	5.000	0.500	0.750
R-33	3.1/2"	150	5.188	0.313	0.560
R-34	3.1/2"	300, 600	5.188	0.438	0.690
R-35	3 "	1500	5.375	0.438	0.690
R-36	4 "	150	5.875	0.313	0.560
R-37	4 "	300, 600, 900	5.875	0.438	0.690
R-38	4 "	2500	6.188	0.625	0.880
R-39	4 "	1500	6.375	0.438	0.690
R-40	5 "	150	6.750	0.313	0.560
R-41	5 "	300, 600, 900	7.125	0.438	0.690
R-42	5 "	2500	7.500	0.750	1.000
R-43	6 "	150	7.625	0.313	0.560
R-44	5 "	1500	7.625	0.438	0.690
R-45	6 "	300, 600, 900	8.313	0.438	0.690
R-46	6 "	1500	8.313	0.500	0.750
R-47	6 "	2500	9.000	0.750	1.000
R-48	8 "	150	9.750	0.313	0.560
R-49	8 "	300, 600, 900	10.625	0.438	0.690
R-50	8 "	1500	10.625	0.625	0.880
R-51	8 "	2500	11.000	0.875	1.130
R-52	10 "	150	12.000	0.313	0.560
R-53	10 "	300, 600, 900	12.750	0.438	0.690
R-54	10 "	1500	12.750	0.625	0.880
R-55	10 "	2500	13.500	1.125	1.440
R-56	12 "	150	15.000	0.313	0.560
R-57	12 "	300, 600, 900	15.000	0.438	0.690
R-58	12 "	1500	15.000	0.875	1.130
R-59	14 "	150	15.625	0.313	0.560
R-60	12 "	2500	16.000	1.250	1.560
R-61	14 "	300, 600	16.500	0.438	0.690
R-62	14 "	900	16.500	0.625	0.880
R-63	14 "	1500	16.500	1.000	1.310
R-64	16 "	150	17.875	0.313	0.560
R-65	16 "	300, 600	18.500	0.438	0.690
R-66	16 "	900	18.500	0.625	0.880
R-67	16 "	1500	18.500	1.125	1.440
R-68	18 "	150	20.375	0.313	0.560
R-69	18 "	300, 600	21.000	0.438	0.690
R-70	18 "	900	21.000	0.750	1.000
R-71	18 "	1500	21.000	1.125	1.440
R-72	20 "	150	22.000	0.313	0.560
R-73	20 "	300, 600	23.000	0.500	0.750
R-74	20 "	900	23.000	0.750	1.000
R-75	20 "	1500	23.000	1.250	1.560
R-76	24 "	150	26.500	0.313	0.560
R-77	24 "	300, 600	27.250	0.625	0.880
R-78	24 "	900	27.250	1.000	1.131

All dimensions in Inches

Type R Oval RTJ Dimensions to ASME B16.20

Ring Number	Nominal Size	Class	Pitch Diameter	Width	Height
R-79	24 "	1500	27.250	1.375	1.750
R-92	-	-	9.000	0.438	0.690

(1) R-30 for lapped joint only

All dimensions in Inches

Klinger Type R Octagonal

Applications:

- Used for high pressure applications.

Typical Properties:

- High integrity seal at high pressures
- Suitable for flat bottom groove flanges
- An improvement on the original oval RTJ design

Typical Specifications:

Material :	Soft Iron
Max. temperature :	400°C
Max. pressure:	Up to Class 2500

Availability:

Manufactured to ASME B16.20 or API 6A
Also available in a range of alloys shown on page 82.

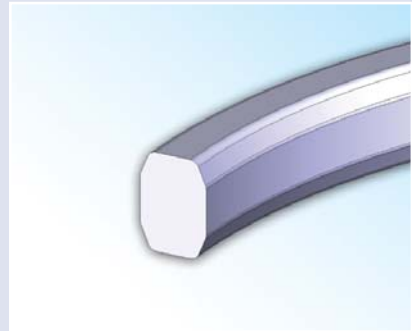

Metallic

Type R Octagonal RTJ Dimensions to ASME B16.20

Ring Number	Nominal Size	Class	Pitch Diameter	Width	Height	Width of Flat	Radius
R-11	1/2"	300, 600	1.344	0.250	0.380	0.170	0.06
R-12	1/2"	900, 1500	1.563	0.313	0.500	0.206	0.06
R-13	3/4"	300, 600	1.688	0.313	0.500	0.206	0.06
R-13	1/2"	2500	1.688	0.313	0.500	0.206	0.06
R-14	3/4"	900, 1500	1.750	0.313	0.500	0.206	0.06
R-15	1 "	150	1.875	0.313	0.500	0.206	0.06
R-16	1 "	300, 600, 900, 1500	2.000	0.313	0.500	0.206	0.06
R-16	3/4"	2500	2.000	0.313	0.500	0.206	0.06
R-17	1.1/4"	150	2.250	0.313	0.500	0.206	0.06
R-18	1.1/4"	300, 600, 900, 1500	2.375	0.313	0.500	0.206	0.06
	1 "	2500	2.375	0.313	0.500	0.206	0.06
R-19	1.1/2"	150	2.563	0.313	0.500	0.206	0.06
R-20	1.1/2"	300, 600, 900, 1500	2.688	0.313	0.500	0.206	0.06
R-21	1.1/4"	2500	2.844	0.438	0.630	0.305	0.06
R-22	2 "	150	3.250	0.313	0.500	0.206	0.06
R-23	2 "	300, 600	3.250	0.438	0.630	0.305	0.06
R-23	1.1/2"	2500	3.250	0.438	0.630	0.305	0.06
R-24	2 "	900, 1500	3.750	0.438	0.630	0.305	0.06
R-25	2.1/2"	150	4.000	0.313	0.500	0.206	0.06
R-26	2.1/2"	300, 600	4.000	0.438	0.630	0.305	0.06
R-26	2 "	2500	4.000	0.438	0.630	0.305	0.06
R-27	2.1/2"	900, 1500	4.250	0.438	0.630	0.305	0.06
R-28	2.1/2"	2500	4.375	0.500	0.690	0.341	0.06
R-29	3 "	150	4.500	0.313	0.500	0.206	0.06
R-30	3" (1)	300	4.625	0.438	0.630	0.305	0.06

All dimensions in Inches

METALLIC RING JOINTS

Type R Octagonal RTJ Dimensions to ASME B16.20

Ring Number	Nominal Size	Class	Pitch Diameter	Width	Height	Width of Flat	Radius
R-31	3 "	300,600,900	4.875	0.438	0.630	0.305	0.06
R-32	3 "	2500	5.000	0.500	0.690	0.341	0.06
R-33	3.1/2"	150	5.188	0.313	0.500	0.206	0.06
R-34	3.1/2"	300,600	5.188	0.438	0.630	0.305	0.06
R-35	3 "	1500	5.375	0.438	0.630	0.305	0.06
R-36	4 "	150	5.875	0.313	0.500	0.206	0.06
R-37	4 "	300,600,900	5.875	0.438	0.630	0.305	0.06
R-38	4 "	2500	6.188	0.625	0.810	0.413	0.06
R-39	4 "	1500	6.375	0.438	0.630	0.305	0.06
R-40	5 "	150	6.750	0.313	0.500	0.206	0.06
R-41	5 "	300,600,900	7.125	0.438	0.630	0.305	0.06
R-42	5 "	2500	7.500	0.750	0.940	0.485	0.06
R-43	6 "	150	7.625	0.313	0.500	0.206	0.06
R-44	5 "	1500	7.625	0.438	0.630	0.305	0.06
R-45	6 "	300,600,900	8.313	0.438	0.630	0.305	0.06
R-46	6 "	1500	8.313	0.500	0.690	0.341	0.06
R-47	6 "	2500	9.000	0.750	0.940	0.485	0.06
R-48	8 "	150	9.750	0.313	0.500	0.206	0.06
R-49	8 "	300,600,900	10.625	0.438	0.630	0.305	0.06
R-50	8 "	1500	10.625	0.625	0.811	0.413	0.06
R-51	8 "	2500	11.000	0.875	1.060	0.583	0.06
R-52	10 "	150	12.000	0.313	0.500	0.206	0.06
R-53	10 "	300,600,900	12.750	0.438	0.630	0.305	0.06
R-54	10 "	1500	12.750	0.625	0.811	0.413	0.06
R-55	10 "	2500	13.500	1.125	1.380	0.780	0.09
R-56	12 "	150	15.000	0.313	0.500	0.206	0.06
R-57	12 "	300,600,900	15.000	0.438	0.630	0.305	0.06
R-58	12 "	1500	15.000	0.875	1.060	0.583	0.06
R-59	14 "	150	15.625	0.313	0.500	0.206	0.06
R-60	12 "	2500	16.000	1.250	1.500	0.879	0.09
R-61	14 "	300,600	16.500	0.438	0.630	0.305	0.06
R-62	14 "	900	16.500	0.625	0.810	0.413	0.06
R-63	14 "	1500	16.500	1.000	1.250	0.681	0.09
R-64	16 "	150	17.875	0.313	0.500	0.206	0.06
R-65	16 "	300,600	18.500	0.438	0.630	0.305	0.06
R-66	16 "	900	18.500	0.625	0.810	0.413	0.06
R-67	16 "	1500	18.500	1.125	1.380	0.780	0.09
R-68	18 "	150	20.375	0.313	0.500	0.206	0.06
R-69	18 "	300,600	21.000	0.438	0.630	0.305	0.06
R-70	18 "	900	21.000	0.750	0.940	0.485	0.06
R-71	18 "	1500	21.000	1.125	1.380	0.780	0.09
R-72	20 "	150	22.000	0.313	0.500	0.206	0.06
R-73	20 "	300,600	23.000	0.500	0.690	0.341	0.06
R-74	20 "	900	23.000	0.750	0.940	0.485	0.06
R-75	20 "	1500	23.000	1.250	1.500	0.879	0.09
R-76	24 "	150	26.500	0.313	0.500	0.206	0.06
R-77	24 "	300,600	27.250	0.625	0.810	0.413	0.06
R-78	24 "	900	27.250	1.000	1.250	0.681	0.09

All dimensions in Inches

Type R Octagonal RTJ Dimensions to ASME B16.20

Ring Number	Nominal Size	Class	Pitch Diameter	Width	Height	Width of Flat	Radius
R-79	24 "	1500	27.250	1.375	1.630	0.977	0.09
R-80	22 "	150	24.250	0.313	0.500	0.206	0.06
R-81	22 "	300, 600	25.000	0.563	0.750	0.377	0.06
R-82	1 "	10000	2.250	0.438	0.630	0.305	0.06
R-84	1.1/2"	10000	2.500	0.438	0.630	0.305	0.06
R-85	2 "	10000	3.125	0.500	0.690	0.341	0.06
R-86	2.1/2"	10000	3.563	0.625	0.810	0.413	0.06
R-87	3 "	10000	3.938	0.625	0.810	0.413	0.06
R-88	4 "	10000	4.875	0.750	0.940	0.485	0.06
R-89	3.1/2"	10000	4.500	0.750	0.940	0.485	0.06
R-90	5 "	10000	6.125	0.875	1.060	0.583	0.06
R-91	10 "	10000	10.250	1.250	1.500	0.879	0.06
R-92	-	-	9.000	0.438	0.630	0.305	0.06
R-93	26 "	300, 600	29.500	0.750	0.940	0.485	0.06
R-94	28 "	300, 600	31.500	0.750	0.940	0.485	0.06
R-95	30 "	300, 600	33.750	0.750	0.940	0.485	0.06
R-96	32 "	300, 600	36.000	0.875	1.060	0.583	0.06
R-97	34 "	300, 600	38.000	0.875	1.060	0.583	0.06
R-98	36 "	300, 600	40.250	0.875	1.060	0.583	0.06
R-99	8 "	2000, 3000	9.250	0.438	0.630	0.305	0.06
R-100	26 "	900	29.500	1.125	1.380	0.780	0.09
R-101	28 "	900	31.500	1.250	1.500	0.879	0.09
R-102	30 "	900	33.750	1.250	1.500	0.879	0.09
R-103	32 "	900	36.000	1.250	1.500	0.879	0.09
R-104	34 "	900	38.000	1.375	1.630	0.977	0.09
R-105	36 "	900	40.250	1.375	1.630	0.977	0.09

Metallic

(1) R-30 for lapped joint only

All dimensions in Inches

Klinger Type RX

Applications:

- Used for high pressure applications
- Interchangeable with Type R Octagonal joints

Typical Properties:

- High integrity seal at high pressures
- Suitable for flat bottom groove flanges
- Pressure energised design improves efficiency of seal with increasing internal pressure
- Can be drilled to create "SRX" ring joint for subsea installation

Typical Specifications:

Material :	Soft Iron
Max. temperature :	400°C
Max. pressure:	Up to Class 5000

Availability:

Manufactured to ASME B16.20 or API 6A
 Also available in a range of alloys shown on page 82.

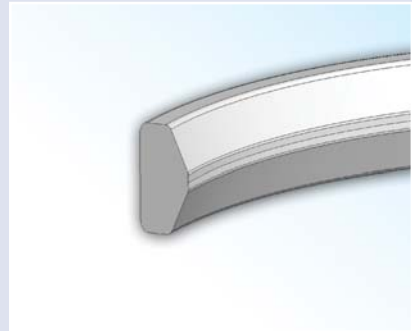

Metallic

Type RX RTJ Dimensions to ASME B16.20

Nominal Size	Ring Number	Class	Outside Diameter	Width	Width of Flat	Height of outside bevel	Height of Ring	Radius	Hole Size
RX-20	1.1/2"	2000, 3000, 5000	3.000	0.344	0.182	0.125	0.750	0.06	-
RX-23	2 "	2000	3.672	0.469	0.254	0.167	1.000	0.06	-
RX-24	2 "	3000, 5000	4.172	0.469	0.254	0.167	1.000	0.06	-
RX-25	3.1/8"	5000	4.313	0.344	0.182	0.125	0.750	0.06	-
RX-26	2.1/2"	2000	4.406	0.469	0.254	0.167	1.000	0.06	-
RX-27	2.1/2"	3000, 5000	4.656	0.469	0.254	0.167	1.000	0.06	-
RX-31	3 "	2000, 3000	5.297	0.469	0.254	0.167	1.000	0.06	-
RX-35	3 "	5000	5.797	0.469	0.254	0.167	1.000	0.06	-
RX-37	4 "	2000, 3000	6.297	0.469	0.254	0.167	1.000	0.06	-
RX-39	4 "	5000	6.797	0.469	0.254	0.167	1.000	0.06	-
RX-41	5 "	2000, 3000	7.547	0.469	0.254	0.167	1.000	0.06	-
RX-44	5 "	5000	8.047	0.469	0.254	0.167	1.000	0.06	-
RX-45	6 "	2000, 3000	8.734	0.469	0.254	0.167	1.000	0.06	-
RX-46	6 "	5000	8.750	0.531	0.263	0.188	1.125	0.06	-
RX-47	8"(1)	5000	9.656	0.781	0.407	0.271	1.625	0.06	-
RX-49	8 "	2000, 3000	11.047	0.469	0.254	0.167	1.000	0.06	-
RX-50	8 "	5000	11.156	0.656	0.335	0.208	1.250	0.06	-
RX-53	10 "	2000, 3000	13.172	0.469	0.254	0.167	1.000	0.06	-
RX-54	10 "	5000	13.281	0.656	0.335	0.208	1.250	0.06	-
RX-57	12 "	2000, 3000	15.422	0.469	0.254	0.167	1.000	0.06	-
RX-63	14 "	5000	17.391	1.063	0.582	0.333	2.000	0.09	-
RX-65	16 "	2000	18.922	0.469	0.254	0.167	1.000	0.06	-
RX-66	16 "	3000	18.031	0.656	0.335	0.208	1.250	0.06	-
RX-69	18 "	2000	21.422	0.469	0.254	0.167	1.000	0.06	-
RX-70	18 "	3000	21.656	0.781	0.407	0.271	1.625	0.09	-

All dimensions in Inches



Telephone : 01274 - 688222
 Fax : 01274 - 688549
 E-mail : enquiries@klingeruk.co.uk

METALLIC RING JOINTS

Type RX RTJ Dimensions to ASME B16.20

Nominal Size	Ring Number	Class	Outside Diameter	Width	Width of Flat	Height of outside bevel	Height of Ring	Radius	Hole Size
RX-73	20 "	2000	23.469	0.531	0.263	0.208	1.250	0.06	-
RX-74	20 "	3000	23.656	0.781	0.407	0.271	1.625	0.09	-
RX-99	8" (1)	2000, 3000	9.672	0.469	0.254	0.167	1.000	0.06	-
RX-201	1.3/8"	5000	2.026	0.226	0.126	0.057	0.445	0.02	-
RX-205	1.13/16"	5000	2.453	0.219	0.120	0.072	0.437	0.02	-
RX-210	2.9/16"	5000	3.844	0.375	0.213	0.125	0.750	0.03	-
RX-215	4.1/16"	5000	5.547	0.469	0.210	0.167	1.000	0.06	-

(1) Crossover flange connection
All dimensions in Inches

Klinger Type BX

Applications:

- Used for high pressure API applications.

Typical Properties:

- Pressure energised design improves efficiency of seal with increasing internal pressure
- Suitable for API 6BX flanges
- Can be drilled to create "SBX" ring joint for subsea installation

Typical Specifications:

Material :	Soft Iron
Max. temperature :	400°C
Max. pressure:	Up to Class 20,000

Availability:

Manufactured to ASME B16.20 or API 6A
 Also available in a range of alloys shown on page 82.

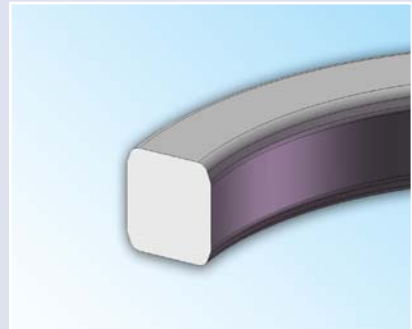

Metallc

Type BX RTJ Dimensions to ASME B16.20

Ring Number	Nominal Size	Class	Outside Diameter	Height of Ring	Width of Ring	Outside Diameter of Flat	Width of Flat	Hole Size
BX-150	1.11/16"	10000, 15000	2.842	0.366	0.366	2.790	0.314	0.06
BX-151	1.13/16"	10000, 15000, 20000	3.008	0.379	0.379	2.954	0.325	0.06
BX-152	2.1/16"	10000, 15000, 20000	3.334	0.403	0.403	3.277	0.346	0.06
BX-153	2.9/16"	10000, 15000, 20000	3.974	0.448	0.448	3.910	0.385	0.06
BX-154	3.1/16"	10000, 15000, 20000	4.600	0.488	0.488	4.531	0.419	0.06
BX-155	4.1/16"	10000, 15000, 20000	5.825	0.560	0.560	5.746	0.481	0.06
BX-156	7.1/16"	10000, 15000, 20000	9.367	0.733	0.733	9.263	0.629	0.12
BX-157	9 "	10000, 15000, 20000	11.593	0.826	0.826	11.476	0.709	0.12
BX-158	11 "	10000, 15000, 20000	13.860	0.911	0.911	13.731	0.782	0.12
BX-159	13.5/8"	10000, 20000	16.800	1.012	1.012	16.657	0.869	0.12
BX-160	13.5/8"	3000	15.850	0.938	0.541	15.717	0.408	0.12
BX-161	16.3/4"	5000	19.347	1.105	0.638	19.191	0.482	0.12
BX-162	16.3/4"	5000, 10000, 15000	18.720	0.560	0.560	18.641	0.481	0.06
BX-163	18.3/4"	5000	21.896	1.185	0.684	21.728	0.516	0.12
BX-164	18.3/4"	10000, 15000	22.463	1.185	0.968	22.230	0.800	0.12
BX-165	21.1/4"	5000	24.595	1.261	0.728	24.417	0.550	0.12
BX-166	21.1/4"	10000	25.198	1.261	1.029	25.020	0.851	0.12

All dimensions in Inches

METALLIC RING JOINTS

Type BX RTJ Dimensions to ASME B16.20

Ring Number	Nominal Size	Class	Outside Diameter	Height of Ring	Width of Ring	Outside Diameter of Flat	Width of Flat	Hole Size
BX-167	26.3/4"	2000	29.896	1.412	0.516	29.696	0.316	0.06
BX-168	26.3/4"	3000	30.128	1.412	0.632	29.928	0.432	0.06
BX-169	5.1/8"	10000	6.831	0.624	0.509	6.743	0.421	0.06
BX-170	6.5/8"	10000, 15000	8.584	0.560	0.560	8.505	0.481	0.06
BX-171	8.9/16"	10000, 15000	10.529	0.560	0.560	10.450	0.481	0.06
BX-172	11.5/32"	10000, 15000	13.113	0.560	0.560	13.034	0.481	0.06
BX-303	30 "	2000, 3000	33.573	1.494	0.668	33.361	0.457	0.06

All dimensions in Inches

Klinger IX Seal Ring

Applications:

- Used for high pressure applications
- For use in compact flanges

Typical Properties:

- High integrity seal at high pressures
- PTFE coating improves corrosion resistance and provides easy identification
- Designed to create a high integrity joint with primary and secondary seals

Typical Specifications:

Material :	As below
Max. temperature :	260°C
Max. pressure:	Up to Class 2500

Availability:

Manufactured to NORSOK L-005

Also available in a range of alloys:

- Low Carbon Steel
- Duplex
- 17/4-PH
- Inconel 625

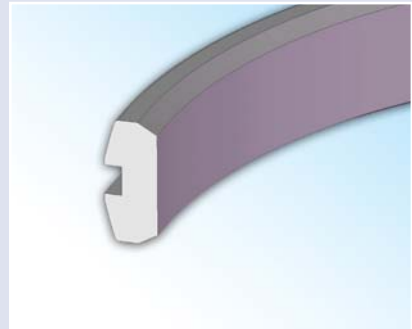

Metallic

Sheet Material



KLINGERSIL



KLINGERTop-chem



KLINGER Graphite

SHEET MATERIAL

Sheet Material Dimensions

Gaskets to suit ANSI B16.5 Flanges.....	102
Gaskets to suit DIN Flanges.....	106
Gaskets to suit BS 10 Flanges	109

KLINGER Quantum

KLINGER Quantum	115
-----------------------	-----

KLINGERtop-sil-ML1

KLINGERtop-sil-ML1	119
--------------------------	-----

KLINGERSIL

KLINGERSIL C-4430	125
KLINGERSIL C-4430+	126
KLINGERSIL C-4400	127
KLINGERSIL C-4324	128
KLINGERSIL C-4500	129
KLINGERSIL C-4509	130
KLINGERSIL C-8200	131
KLINGERSIL C-6307	132
KLINGERSIL C-4106	133
KLINGERSIL C-4265.....	134

KLINGERtop-graph-2000

KLINGERtop-graph-2000.....	135
----------------------------	-----

KLINGER Graphite

Klinger TSM-AS	142
Klinger PSM-AS	143
Klinger SLS-AS	144
Klinger PSM-AS with eyelet	145

KLINGERtop-chem

KLINGERtop-chem-2000	149
KLINGERtop-chem-2003	150
KLINGERtop-chem-2005	151
KLINGERtop-chem-2006	152

PTFE

KLINGERsoft-chem	155
KLINGERsealex	156
PTFE Envelope	157

GORE™ Sealant Technologies

GORE™ Universal Pipe Gasket (Style 800)	161
GORE™ GR	162
GORE™ Joint Sealant DF Tape	163
GORE™ Series 500 Gasket Tape	164
GORE™ Series 600 Gasket Tape	165

High Temperature

KLINGER Thermica	169
KLINGERmilam-PSS	170
KLINGER Ferroflex SP-AFII	171

Paper, Cork & Rubber

KLINGERstatite	175
Klinger NI 27	176
Klinger NI 552	177
Klinger NE 32	178
SBR	179
Neoprene®	179
Nitrile	180
EPDM	180
Hypalon®	181
Viton®	181
Butyl	182
NR	182
Silicone	183
Polyurethane	183

Insulation Sets

Klinger VCS & VCFS	187
Klinger PGE	188
Phenolic insulating gasket, type : E	189
Phenolic insulating gaskets, Type : F	190
Dimensions to suit ANSI B16.5 flanges	191
Dimensions to suit DIN flanges	193

Dimensions for Cut Gaskets



SOFT-CUT GASKET DIMENSIONS

Dimensions to suit ANSI Standard Flanges ASME B16.21 Class 150

Nominal Bore (inches)	I.B.C. Gasket	Full Face gasket			
	OD x ID (mm)	OD x ID (mm)	Number of Bolt Holes	Hole Diameter (mm)	Bolt P.C.D. (mm)
1/2	48 x 21	89 x 21	4	16	60
3/4	57 x 27	95 x 27	4	16	70
1	67 x 33	108 x 33	4	16	79
1 1/4	76 x 42	117 x 42	4	16	89
1 1/2	86 x 48	127 x 48	4	16	98
2	105 x 60	152 x 60	4	19	121
2 1/2	124 x 73	178 x 73	4	19	140
3	137 x 89	191 x 89	4	19	152
3 1/2	162 x 102	216 x 102	8	19	178
4	175 x 114	229 x 114	8	19	191
5	197 x 141	254 x 141	8	22	216
6	222 x 168	279 x 168	8	22	241
8	279 x 219	343 x 219	8	22	298
10	340 x 273	406 x 273	12	25	362
12	410 x 324	483 x 324	12	25	432
14	451 x 356	533 x 356	12	29	476
16	514 x 406	597 x 406	16	29	540
18	549 x 457	635 x 457	16	32	578
20	606 x 508	699 x 508	20	32	635
24	718 x 610	813 x 610	20	35	749

ASME B16.21 Class 300

Nominal Bore (inches)	I.B.C. Gasket	Full Face gasket			
	OD x ID (mm)	OD x ID (mm)	Number of Bolt Holes	Hole Diameter (mm)	Bolt P.C.D. (mm)
1/2	54 x 21	95 x 21	4	16	67
3/4	67 x 27	117 x 27	4	19	83
1	73 x 33	124 x 33	4	19	89
1 1/4	83 x 42	133 x 42	4	19	98
1 1/2	95 x 48	156 x 48	4	22	114
2	111 x 60	165 x 60	8	19	127
2 1/2	130 x 73	191 x 73	8	22	149
3	149 x 89	210 x 89	8	22	168
3 1/2	165 x 102	229 x 102	8	22	184
4	181 x 114	254 x 114	8	22	200
5	216 x 141	279 x 141	8	22	235
6	251 x 168	318 x 168	12	22	270
8	308 x 219	381 x 219	12	25	330
10	362 x 273	445 x 273	16	29	387
12	422 x 324	521 x 324	16	32	451
14	486 x 356	584 x 356	20	32	514
16	540 x 406	648 x 406	20	35	572
18	597 x 457	711 x 457	24	35	629
20	654 x 508	775 x 508	24	35	686
24	775 x 610	914 x 610	24	41	813

ASME B16.21 Class 600

Nominal Bore (inches)	I.B.C. Gasket	Full Face gasket			
	OD x ID (mm)	OD x ID (mm)	Number of Bolt Holes	Hole Diameter (mm)	Bolt P.C.D. (mm)
1/2	54 x 21	95 x 21	4	16	67
3/4	67 x 27	117 x 27	4	19	83
1	73 x 33	124 x 33	4	19	89
1 1/4	83 x 42	133 x 42	4	19	98
1 1/2	95 x 48	156 x 48	4	22	114
2	111 x 60	165 x 60	8	19	127
2 1/2	130 x 73	191 x 73	8	22	149
3	149 x 89	210 x 89	8	22	168
3 1/2	162 x 102	229 x 102	8	25	184
4	194 x 114	273 x 114	8	25	216
5	241 x 141	330 x 141	8	29	267
6	267 x 168	356 x 168	12	29	292
8	321 x 219	419 x 219	12	32	349
10	400 x 273	508 x 273	16	35	432
12	457 x 324	559 x 324	20	35	489
14	492 x 356	603 x 356	20	38	527
16	565 x 406	686 x 406	20	41	603
18	613 x 457	743 x 457	20	44	654
20	683 x 508	813 x 508	24	44	724
24	791 x 610	940 x 610	24	51	838

ASME B16.47 A Class 150

Nominal Bore Inches (mm)	I.B.C. Gasket	Full Face gasket			
	OD x ID (mm)	OD x ID (mm)	Number of Bolt Holes	Hole Diameter (mm)	Bolt P.C.D. (mm)
22 (550)	660 x 559	749 x 559	20	35	692
26 (650)	775 x 660	870 x 660	24	35	806
28 (700)	832 x 711	927 x 711	28	35	864
30 (750)	883 x 762	984 x 762	28	35	914
32 (800)	940 x 813	1060 x 813	28	41	978
34 (850)	991 x 864	1111 x 864	32	41	1029
36 (900)	1048 x 914	1168 x 914	32	41	1086
38 (950)	1111 x 965	1238 x 965	32	41	1149
40 (1000)	1162 x 1016	1289 x 1016	36	41	1200
42 (1050)	1219 x 1067	1346 x 1067	36	41	1257
44 (1100)	1276 x 1118	1403 x 1118	40	41	1314
46 (1150)	1327 x 1168	1454 x 1168	40	41	1365
48 (1200)	1384 x 1219	1511 x 1219	44	41	1422
50 (1250)	1435 x 1270	1568 x 1270	44	48	1480
52 (1300)	1492 x 1321	1626 x 1321	44	48	1537
54 (1350)	1549 x 1372	1683 x 1372	44	48	1594
56 (1400)	1607 x 1422	1746 x 1422	48	48	1651
58 (1450)	1664 x 1473	1803 x 1473	48	48	1708
60 (1500)	1715 x 1524	1854 x 1524	52	48	1759

SOFT-CUT GASKET DIMENSIONS

ASME B16.47 A Class 300

Nominal Bore Inches (mm)	I.B.C. Gasket	Full Face gasket			
	OD x ID (mm)	OD x ID (mm)	Number of Bolt Holes	Hole Diameter (mm)	Bolt P.C.D. (mm)
22 (550)	705 x 559	838 x 559	24	41	743
26 (650)	835 x 660	972 x 660	28	44	876
28 (700)	899 x 711	1035 x 711	28	44	940
30 (750)	953 x 762	1092 x 762	28	48	997
32 (800)	1007 x 813	1149 x 813	28	51	1054
34 (850)	1057 x 864	1207 x 864	28	51	1105
36 (900)	1118 x 914	1270 x 914	32	54	1168
38 (950)	1054 x 965	1168 x 965	32	41	1092
40 (1000)	1115 x 1016	1238 x 1016	32	44	1156
42 (1050)	1165 x 1067	1289 x 1067	32	44	1207
44 (1100)	1219 x 1118	1353 x 1118	32	48	1264
46 (1150)	1273 x 1168	1416 x 1168	28	51	1321
48 (1200)	1324 x 1219	1467 x 1219	32	51	1372
50 (1250)	1378 x 1270	1581 x 1321	32	54	1429
52 (1300)	1429 x 1321	1657 x 1372	32	54	1480
54 (1400)	1492 x 1372	1683 x 1372	28	60	1579
56 (1450)	1543 x 1422	1708 x 1422	28	60	1600
58 (1500)	1594 x 1473	1759 x 1473	32	60	1651
60 (1550)	1645 x 1524	1810 x 1524	32	60	1702

ASME B16.47 A Class 600

Nominal Bore Inches (mm)	I.B.C. Gasket.	Full Face gasket			
	OD x ID (mm)	OD x ID (mm)	Number of Bolt Holes	Hole Diameter (mm)	Bolt P.C.D. (mm)
22 (550)	733 x 559	870 x 559	24	48	778
26 (650)	867 x 660	1016 x 660	28	51	914
28 (700)	914 x 711	1073 x 711	28	54	965
30 (750)	972 x 762	1130 x 762	28	54	1022
32 (800)	1022 x 813	1194 x 813	28	60	1080
34 (850)	1073 x 864	1245 x 864	28	60	1130
36 (900)	1130 x 914	1314 x 914	28	67	1194
38 (950)	1105 x 965	1270 x 965	28	60	1162
40 (1000)	1156 x 1016	1321 x 1016	32	60	1213
42 (1050)	1219 x 1067	1403 x 1067	28	67	1283
44 (1100)	1270 x 1118	1454 x 1118	32	67	1334
46 (1150)	1327 x 1168	1511 x 1168	32	67	1391
48 (1200)	1391 x 1219	1594 x 1219	32	73	1461
50 (1250)	1448 x 1270	1670 x 1270	28	79	1524
52 (1300)	1499 x 1321	1721 x 1321	32	79	1575
54 (1350)	1556 x 1372	1778 x 1372	32	79	1632
56 (1400)	1613 x 1422	1854 x 1422	32	86	1695
58 (1450)	1664 x 1473	1905 x 1473	32	86	1746
60 (1500)	1721 x 1524	1994 x 1524	28	92	1822

ASME B16.47 B Class 150

Nominal Bore Inches (mm)	I.B.C. Gasket	Full Face gasket			
	OD x ID (mm)	OD x ID (mm)	Number of Bolt Holes	Hole Diameter (mm)	Bolt P.C.D. (mm)
26 (650)	725 x 660	786 x 660	36	22	745
28 (700)	776 x 711	837 x 711	40	22	795
30 (750)	827 x 762	887 x 762	44	22	846
32 (800)	881 x 813	941 x 813	48	22	900
34 (850)	935 x 864	1005 x 864	40	25	957
36 (900)	987 x 914	1057 x 914	44	25	1010
38 (950)	1045 x 965	1124 x 965	40	29	1070
40 (1000)	1095 x 1016	1175 x 1016	44	29	1121
42 (1050)	1146 x 1067	1226 x 1067	48	29	1172
44 (1100)	1197 x 1118	1276 x 1118	52	29	1222
46 (1150)	1256 x 1168	1341 x 1168	40	32	1284
48 (1200)	1307 x 1219	1392 x 1219	44	32	1335
50 (1250)	1357 x 1270	1443 x 1270	48	32	1386
52 (1300)	1408 x 1321	1494 x 1321	52	32	1437
54 (1350)	1464 x 1372	1549 x 1372	56	32	1492
56 (1400)	1514 x 1422	1600 x 1422	60	32	1543
58 (1450)	1580 x 1473	1675 x 1473	48	35	1611
60 (1500)	1630 x 1524	1726 x 1524	52	35	1662

ASME B16.47 B Class 300

Nominal Bore Inches (mm)	IBC Gasket	Full Face gasket			
	OD x ID (mm)	OD x ID (mm)	Number of Bolt Holes	Hole Diameter (mm)	Bolt P.C.D. (mm)
26 (650)	772 x 660	867 x 660	32	35	803
28 (700)	826 x 711	921 x 711	36	35	857
30 (750)	886 x 762	991 x 762	36	38	921
32 (800)	940 x 813	1054 x 813	32	41	978
34 (850)	994 x 864	1108 x 864	36	41	1032
36 (900)	1048 x 914	1172 x 914	32	44	1089
38 (950)	1099 x 965	1222 x 965	36	44	1140
40 (1000)	1149 x 1016	1273 x 1016	40	44	1191
42 (1050)	1200 x 1067	1334 x 1067	36	48	1245
44 (1100)	1251 x 1118	1384 x 1118	40	48	1295
46 (1150)	1318 x 1168	1461 x 1168	36	51	1365
48 (1200)	1368 x 1219	1511 x 1219	40	51	1416
50 (1250)	1419 x 1270	1562 x 1270	44	51	1467
52 (1300)	1470 x 1321	1613 x 1321	48	51	1518
54 (1350)	1556 x 1372	1673 x 1372	48	51	1578
56 (1400)	1594 x 1422	1765 x 1422	36	60	1651
58 (1450)	1673 x 1473	1827 x 1473	40	60	1713
60 (1500)	1705 x 1524	1878 x 1524	40	60	1764

SOFT-CUT GASKET DIMENSIONS

ASME B16.47 B Class 600 (continued)

Nominal Bore Inches (mm)	I.B.C. Gasket	Full Face gasket			
	OD x ID (mm)	OD x ID (mm)	Number of Bolt Holes	Hole Diameter (mm)	Bolt P.C.D. (mm)
26 (650)	765 x 660	889 x 660	28	44	806
28 (700)	819 x 711	953 x 711	28	48	864
30 (750)	879 x 762	1022 x 762	28	51	927
32 (800)	933 x 813	1086 x 813	28	54	984
34 (850)	997 x 864	1162 x 864	24	60	1054
36 (900)	1048 x 914	1213 x 914	28	60	1105

Dimensions to suit DIN Standard Flanges

PN10

Nominal Bore	I.B.C. Gasket	Full Face gasket			
	OD x ID (mm)	OD x ID (mm)	Number of Bolt Holes	Hole Diameter (mm)	Bolt P.C.D. (mm)
10	45 x 18	90 x 18	4	14	60
15	50 x 22	95 x 22	4	14	65
20	60 x 28	105 x 28	4	14	75
25	70 x 35	115 x 35	4	14	85
32	82 x 43	140 x 43	4	18	100
40	92 x 49	150 x 49	4	18	110
50	107 x 61	165 x 61	4	18	125
65	127 x 77	185 x 77	8*	18	145
80	142 x 90	200 x 90	8	18	160
100	162 x 115	220 x 115	8	18	180
125	192 x 141	250 x 141	8	18	210
150	218 x 169	285 x 169	8	22	240
200	273 x 220	340 x 220	8	22	295
250	328 x 274	395 x 274	12	22	350
300	378 x 325	445 x 325	12	22	400
350	438 x 356	505 x 356	16	22	460
400	489 x 407	565 x 407	16	26	515
450	539 x 458	615 x 458	20	26	565
500	594 x 508	670 x 508	20	26	620
600	695 x 610	780 x 610	20	30	725
700	810 x 712	895 x 712	24	30	840
800	917 x 813	1015 x 813	24	33	950
900	1017 x 915	1115 x 915	28	33	1050
1000	1124 x 1016	1230 x 1016	28	36	1160
1100	1231 x 1120	1340 x 1120	32	39	1270
1200	1341 x 1220	1455 x 1220	32	39	1380
1400	1548 x 1420	1675 x 1420	36	42	1590
1500	1658 x 1520	1785 x 1520	36	42	1700
1600	1772 x 1620	1915 x 1620	40	48	1820
1800	1972 x 1820	2115 x 1820	44	48	2020
2000	2182 x 2020	2325 x 2020	48	48	2230

* Gaskets for cast iron and copper alloy flanges may have 4 bolt holes

PN16

Nominal Bore	IBC Gasket	Full Face gasket			
	OD x ID (mm)	OD x ID (mm)	Number of Bolt Holes	Hole Diameter (mm)	Bolt P.C.D. (mm)
10	45 x 18	90 x 18	4	14	60
15	50 x 22	95 x 22	4	14	65
20	60 x 28	105 x 28	4	14	75
25	70 x 35	115 x 35	4	14	85
32	82 x 43	140 x 43	4	18	100
40	92 x 49	150 x 49	4	18	110
50	107 x 61	165 x 61	4	18	125
65	127 x 77	185 x 77	8*	18	145
80	142 x 90	200 x 90	8	18	160
100	162 x 115	220 x 115	8	18	180
125	192 x 141	250 x 141	8	18	210
150	218 x 169	285 x 169	8	22	240
200	273 x 220	340 x 220	12	22	295
250	329 x 274	405 x 274	12	26	355
300	384 x 325	460 x 325	12	26	410
350	444 x 356	520 x 356	16	26	470
400	495 x 407	580 x 407	16	30	525
450	555 x 458	640 x 458	20	30	585
500	617 x 508	715 x 508	20	33	650
600	734 x 610	840 x 610	20	36	770
700	804 x 712	910 x 712	24	36	840
800	911 x 813	1025 x 813	24	39	950
900	1011 x 915	1125 x 915	28	39	1050
1000	1128 x 1016	1255 x 1016	28	42	1170
1100	1228 x 1120	1355 x 1120	32	42	1270
1200	1342 x 1220	1485 x 1220	32	48	1390
1400	1542 x 1420	1685 x 1420	36	48	1590
1500	1654 x 1520	1820 x 1520	36	56	1710
1600	1764 x 1620	1930 x 1620	40	56	1820
1800	1964 x 1820	2130 x 1820	44	56	2020
2000	2168 x 2020	2345 x 2020	48	62	2230

* Gaskets for cast iron and copper alloy flanges may have 4 bolt holes

PN25

Nominal Bore	IBC Gasket	Full Face gasket			
	OD x ID (mm)	OD x ID (mm)	Number of Bolt Holes	Hole Diameter (mm)	Bolt P.C.D. (mm)
10	45 x 18	90 x 18	4	14	60
15	50 x 22	95 x 22	4	14	65
20	60 x 28	105 x 28	4	14	75
25	70 x 35	115 x 35	4	14	85
32	82 x 43	140 x 43	4	18	100
40	92 x 49	150 x 49	4	18	110
50	107 x 61	165 x 61	4	18	125
65	127 x 77	185 x 77	8	18	145
80	142 x 90	200 x 90	8	18	160

SOFT-CUT GASKET DIMENSIONS

PN25 (continued)

Nominal Bore	I.B.C. Gasket		Full Face gasket		
	OD x ID (mm)	OD x ID (mm)	Number of Bolt Holes	Hole Diameter (mm)	Bolt P.C.D. (mm)
100	162 x 115	220 x 115	8	18	180
125	192 x 141	250 x 141	8	18	210
150	218 x 169	285 x 169	12	22	240
200	273 x 220	340 x 220	12	22	295
250	329 x 274	405 x 274	12	26	355
300	384 x 325	460 x 325	16	26	410
350	444 x 356	520 x 356	16	26	470
400	514 x 407	620 x 407	16	36	550
450	564 x 458	670 x 458	20	36	600
500	624 x 508	730 x 508	20	36	660
600	731 x 610	845 x 610	20	39	770
700	833 x 712	960 x 712	24	42	875
800	942 x 813	1085 x 813	24	48	990
900	1042 x 915	1185 x 915	28	48	1090
1000	1154 x 1016	1320 x 1016	28	56	1210
1100	1254 x 1120	1420 x 1120	32	56	1310
1200	1364 x 1220	1530 x 1220	32	56	1420
1400	1578 x 1420	1755 x 1420	36	62	1640
1500	1688 x 1520	1865 x 1520	36	62	1750
1600	1798 x 1620	1975 x 1620	40	62	1860
1800	2000 x 1820	2195 x 1820	44	70	2070
2000	2230 x 2020	2425 x 2020	48	70	2300

Sheet Material

PN40

Nominal Bore	I.B.C. Gasket		Full Face gasket		
	OD x ID (mm)	OD x ID (mm)	Number of Bolt Holes	Hole Diameter (mm)	Bolt P.C.D. (mm)
10	45 x 18	90 x 18	4	14	60
15	50 x 22	95 x 22	4	14	65
20	60 x 28	105 x 28	4	14	75
25	70 x 35	115 x 35	4	14	85
32	82 x 43	140 x 43	4	18	100
40	92 x 49	150 x 49	4	18	110
50	107 x 61	165 x 61	4	18	125
65	127 x 77	185 x 77	8	18	145
80	142 x 90	200 x 90	8	18	160
100	168 x 115	235 x 115	8	22	190
125	194 x 141	270 x 141	8	26	220
150	224 x 169	300 x 169	8	26	250
200	290 x 220	375 x 220	12	30	320
250	352 x 274	450 x 274	12	33	385
300	417 x 325	515 x 325	16	33	450
350	474 x 356	580 x 356	16	36	510
400	546 x 407	660 x 407	16	39	585

PN40 (continued)

Nominal Bore	IBC Gasket		Full Face gasket		
	OD x ID (mm)	OD x ID (mm)	Number of Bolt Holes	Hole Diameter (mm)	Bolt P.C.D. (mm)
450	571 x 458	685 x 458	20	39	610
500	628 x 508	755 x 508	20	42	670
600	747 x 610	890 x 610	20	48	795
700	852 x 710	995 x 710	24	48	900
800	974 x 820	1140 x 820	24	56	1030
900	1084 x 910	1250 x 910	28	56	1140
1000	1194 x 1010	1360 x 1010	28	56	1250

Gaskets for use with BS10 Flanges

Table A

Nominal Bore (inches)	IBC Gasket		Full Face gasket		
	OD x ID (mm)	OD x ID (mm)	Number of Bolt Holes	Hole Diameter (mm)	Bolt P.C.D. (mm)
1/2	52 x 21	95 x 21	4	14	67
3/4	59 x 27	102 x 27	4	14	73
1	68 x 34	114 x 34	4	14	83
1 1/4	73 x 43	121 x 43	4	14	87
1 1/2	84 x 48	133 x 48	4	14	98
2	97 x 60	152 x 60	4	18	114
2 1/2	110 x 76	165 x 76	4	18	127
3	129 x 89	184 x 89	4	18	146
3 1/2	148 x 102	203 x 102	4	18	165
4	160 x 114	216 x 114	4	18	178
5	192 x 140	254 x 140	4	18	210
6	217 x 168	279 x 168	4	18	235
7	243 x 194	305 x 194	8	18	260
8	275 x 219	337 x 219	8	18	292
9	306 x 244	368 x 244	8	18	324
10	333 x 273	406 x 273	8	22	356
12	384 x 324	457 x 324	8	22	406
13	416 x 356	489 x 356	8	22	438
14	445 x 381	527 x 381	8	25	470
15	470 x 406	552 x 406	8	25	495
16	495 x 432	578 x 432	12	25	521
17	527 x 457	610 x 457	12	25	552
18	559 x 483	641 x 483	12	25	584
19	584 x 508	673 x 508	12	25	610
20	616 x 533	705 x 533	12	25	641
21	648 x 559	737 x 559	12	25	673
22	670 x 584	762 x 584	12	29	699
23	695 x 610	787 x 610	12	29	724
24	727 x 635	826 x 635	12	29	756

Sheet Material

SOFT-CUT GASKET DIMENSIONS

Table D

Nominal Bore (inches)	I.B.C. Gasket	Full Face gasket			
	OD x ID (mm)	OD x ID (mm)	Number of Bolt Holes	Hole Diameter (mm)	Bolt P.C.D. (mm)
1/2	52 x 21	95 x 21	4	14	67
3/4	59 x 27	102 x 27	4	14	73
1	68 x 34	114 x 34	4	14	83
1 1/4	73 x 43	121 x 43	4	14	87
1 1/2	84 x 48	133 x 48	4	14	98
2	97 x 60	152 x 60	4	18	114
2 1/2	110 x 76	165 x 76	4	18	127
3	129 x 89	184 x 89	4	18	146
3 1/2	148 x 102	203 x 102	4	18	165
4	160 x 114	216 x 114	4	18	178
5	192 x 140	254 x 140	8	18	210
6	216 x 168	279 x 168	8	18	235
7	243 x 194	305 x 194	8	18	260
8	275 x 219	337 x 219	8	18	292
9	306 x 244	368 x 244	8	18	324
10	333 x 273	406 x 273	8	22	356
12	384 x 324	457 x 324	12	22	406
13	416 x 356	489 x 356	12	22	438
14	445 x 381	527 x 381	12	25	470
15	470 x 406	552 x 406	12	25	495
16	495 x 432	578 x 432	12	25	521
17	527 x 457	610 x 457	12	25	552
18	559 x 483	641 x 483	12	25	584
19	584 x 508	673 x 508	12	25	610
20	616 x 533	705 x 533	16	25	641
21	648 x 559	737 x 559	16	25	673
22	670 x 584	762 x 584	16	29	699
23	695 x 610	787 x 610	16	29	724
24	727 x 635	826 x 635	16	29	756

Sheet Material

BS10 Table E

Nominal Bore (inches)	IBC Gasket	Full Face gasket			
	OD x ID (mm)	OD x ID (mm)	Number of Bolt Holes	Hole Diameter (mm)	Bolt P.C.D. (mm)
1/2	52 x 21	95 x 21	4	14	67
3/4	59 x 27	102 x 27	4	14	73
1	68 x 34	114 x 34	4	14	83
1 1/4	73 x 43	121 x 43	4	14	87
1 1/2	84 x 48	133 x 48	4	14	98
2	97 x 60	152 x 60	4	18	114
2 1/2	109 x 76	165 x 76	4	18	127
3	129 x 89	184 x 89	4	18	146
3 1/2	148 x 102	203 x 102	8	18	165
4	160 x 114	216 x 114	8	18	178
5	192 x 140	254 x 140	8	18	210
6	213 x 168	279 x 168	8	22	235

BS10 Table E (continued)

Nominal Bore (inches)	IBC Gasket		Full Face gasket		
	OD x ID (mm)	OD x ID (mm)	Number of Bolt Holes	Hole Diameter (mm)	Bolt P.C.D. (mm)
7	238 x 194	305 x 194	8	22	260
8	270 x 219	337 x 219	8	22	292
9	302 x 244	368 x 244	12	22	324
10	333 x 273	406 x 273	12	22	356
12	381 x 324	457 x 324	12	25	406
13	413 x 356	489 x 356	12	25	438
14	445 x 381	527 x 381	12	25	470
15	470 x 406	552 x 406	12	25	495
16	495 x 432	578 x 432	12	25	521
17	527 x 457	610 x 457	12	25	552
18	559 x 483	641 x 483	16	25	584
19	584 x 508	673 x 508	16	25	610
20	616 x 533	705 x 533	16	25	641
21	645 x 559	737 x 559	16	29	673
22	670 x 584	762 x 584	16	29	699
23	695 x 610	787 x 610	16	29	724
24	724 x 635	826 x 635	16	32	756

BS10 Table F

Nominal Bore (inches)	IBC Gasket		Full Face gasket		
	OD x ID (mm)	OD x ID (mm)	Number of Bolt Holes	Hole Diameter (mm)	Bolt P.C.D. (mm)
1/2	52 x 21	95 x 21	4	14	67
3/4	59 x 27	102 x 27	4	14	73
1	70 x 34	121 x 34	4	18	87
1 1/4	81 x 43	133 x 43	4	18	98
1 1/2	86 x 48	140 x 48	4	19	105
2	110 x 60	165 x 60	4	18	127
2 1/2	129 x 76	184 x 76	8	18	146
3	148 x 89	203 x 89	8	18	165
3 1/2	160 x 102	216 x 102	8	18	178
4	173 x 114	229 x 114	8	18	191
5	213 x 140	279 x 140	8	22	235
6	238 x 168	305 x 168	12	22	260
7	270 x 194	337 x 194	12	22	292
8	302 x 219	368 x 219	12	22	324
9	330 x 244	406 x 244	12	25	356
10	356 x 273	432 x 273	12	25	381
12	413 x 324	489 x 324	16	25	438
13	441 x 356	527 x 356	16	29	470
14	467 x 381	552 x 381	16	29	495
15	492 x 406	578 x 406	16	29	521
16	524 x 432	610 x 432	20	29	552
17	556 x 457	641 x 457	20	29	584
18	578 x 483	673 x 483	20	32	610
19	610 x 508	705 x 508	20	32	641

SOFT-CUT GASKET DIMENSIONS

BS10 Table F (continued)

Nominal Bore (inches)	IBC Gasket		Full Face gasket		
	OD x ID (mm)	OD x ID (mm)	Number of Bolt Holes	Hole Diameter (mm)	Bolt P.C.D. (mm)
20	641 x 533	737 x 533	24	32	673
21	667 x 559	762 x 559	24	32	699
22	692 x 584	787 x 584	24	32	724
23	721 x 610	826 x 610	24	35	756
24	746 x 635	851 x 635	24	35	781

BS10 Table H

Nominal Bore (inches)	IBC Gasket		Full Face gasket		
	OD x ID (mm)	OD x ID (mm)	Number of Bolt Holes	Hole Diameter (mm)	Bolt P.C.D. (mm)
1/2	65 x 21	114 x 21	4	18	83
3/4	65 x 27	114 x 27	4	18	83
1	70 x 34	121 x 34	4	18	87
1 1/4	81 x 43	133 x 43	4	18	98
1 1/2	87 x 48	140 x 48	4	18	105
2	110 x 60	165 x 60	4	18	127
2 1/2	129 x 76	184 x 76	8	18	146
3	148 x 89	203 x 89	8	18	165
3 1/2	160 x 102	216 x 102	8	18	178
4	173 x 114	229 x 114	8	18	191
5	213 x 140	279 x 140	8	22	235
6	238 x 168	305 x 168	12	22	260
7	270 x 194	337 x 194	12	22	292
8	302 x 219	368 x 219	12	22	324
9	330 x 244	406 x 244	12	25	356
10	356 x 273	432 x 273	12	25	381
12	413 x 324	489 x 324	16	25	438
13	441 x 356	527 x 356	16	29	470
14	467 x 381	552 x 381	16	29	495
15	492 x 406	578 x 406	16	29	521
16	524 x 432	610 x 432	20	29	552
17	556 x 457	641 x 457	20	29	584
18	578 x 483	673 x 483	20	32	610
19	610 x 508	705 x 508	20	32	641
20	641 x 533	737 x 533	24	32	673
21	667 x 559	762 x 559	24	32	699
22	692 x 584	787 x 584	24	32	724
23	721 x 610	826 x 610	24	35	756
24	746 x 635	851 x 635	24	35	781

BS10 Table J

Nominal Bore (inches)	IBC Gasket		Full Face gasket		
	OD x ID (mm)	OD x ID (mm)	Number of Bolt Holes	Hole Diameter (mm)	Bolt P.C.D. (mm)
1/2	65 x 21	114 x 21	4	18	83
3/4	65 x 27	114 x 27	4	18	83
1	70 x 34	121 x 34	4	18	87
1 1/4	81 x 43	133 x 43	4	18	98
1 1/2	87 x 48	140 x 48	4	18	105
2	110 x 60	165 x 60	4	22	127
2 1/2	129 x 76	184 x 76	8	22	146
3	148 x 89	203 x 89	8	22	165

BS10 Table J (continued)

Nominal Bore (inches)	IBC Gasket		Full Face gasket		
	OD x ID (mm)	OD x ID (mm)	Number of Bolt Holes	Hole Diameter (mm)	Bolt P.C.D. (mm)
3 1/2	160 x 102	216 x 102	8	22	178
4	173 x 114	229 x 114	8	22	191
5	213 x 140	279 x 140	8	25	235
6	238 x 168	305 x 168	12	25	260
7	270 x 194	337 x 194	12	25	292
8	302 x 219	368 x 219	12	25	324
9	330 x 244	406 x 244	12	29	356
10	356 x 273	432 x 273	12	29	381
12	413 x 324	489 x 324	16	29	438
13	441 x 356	527 x 356	16	32	470
14	467 x 381	552 x 381	16	32	495
15	492 x 406	578 x 406	16	32	521
16	524 x 432	610 x 432	20	32	552
17	556 x 457	641 x 457	20	32	584
18	578 x 483	673 x 483	20	35	610
19	610 x 508	705 x 508	20	35	641
20	641 x 533	737 x 533	24	35	673
21	667 x 559	762 x 559	24	35	699
22	692 x 584	787 x 584	24	35	724
23	721 x 610	826 x 610	24	38	756
24	746 x 635	851 x 635	24	38	781

BS10 Table K

Nominal Bore (inches)	IBC Gasket		Full Face gasket		
	OD x ID (mm)	OD x ID (mm)	Number of Bolt Holes	Hole Diameter (mm)	Bolt P.C.D. (mm)
1/2	65 x 21	114 x 21	4	18	83
3/4	65 x 27	114 x 27	4	18	83
1	78 x 34	127 x 34	4	18	95
1 1/4	81 x 43	133 x 43	4	18	98
1 1/2	92 x 48	152 x 48	4	22	114
2	110 x 60	165 x 60	8	18	127
2 1/2	124 x 76	184 x 76	8	22	146
3	143 x 89	203 x 89	8	22	165
3 1/2	159 x 102	229 x 102	8	25	184
4	171 x 114	241 x 114	8	25	197
5	210 x 140	279 x 140	12	25	235
6	235 x 168	305 x 168	12	25	260
7	264 x 191	343 x 191	12	29	292
8	289 x 216	368 x 216	12	29	318
9	327 x 241	406 x 241	16	29	356
10	352 x 270	432 x 270	16	29	381
12	400 x 321	489 x 321	16	29	432
13	448 x 346	546 x 346	16	35	483
14	473 x 371	572 x 371	16	35	508
15	505 x 397	603 x 397	20	35	540

KLINGER Quantum



Introduction

Ever since the development of non-asbestos fibre gasket materials in the early 1980s users have been searching for a material with the high temperature properties of Klingerit compressed asbestos fibre. Klinger, as the leading manufacturer of static gasket materials was the pioneer in the development of non-asbestos based gasket materials and continue to develop materials which push the limitations of fibre reinforced gaskets. Until recently the material with the highest temperature capability was Klinger-top-sil-ML1 which was developed to extend the range of non-asbestos based materials by increasing the usable temperature by the incorporation of a multi-layer structure with an HNBR binder.

Klinger have now developed Quantum to bring an unprecedented level of flexibility for fibre reinforced gasket materials at high temperatures. Klinger Quantum is exclusively HNBR bound which affords the material excellent temperature resistance and resistance across a much broader range of chemicals than all other fibre reinforced gasket materials.

Flexibility at High Temperatures

When a gasket material remains flexible it can more readily adapt to expansion and pressure variations without crack formation and subsequent leakage. The simple 3-point bending test is often used for the evaluation of fibre reinforced materials. By conditioning the test samples at temperature for a given duration this test can be used to evaluate the brittleness and ageing behaviour of the elastomeric binder.

The results shown in figures 1 & 2 show the flexibility of Klinger Quantum and that of a standard fibre reinforced material. After the test Klinger Quantum shows outstanding flexibility; several times that of traditional fibre based materials:



Figure 1 - Klinger Quantum

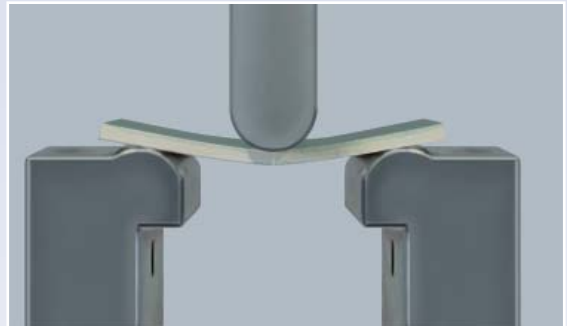

Figure 2 - Standard fibre material

Both materials were conditioned at 200°C for 48 hours

Klinger Quantum & Quantum FDA

Applications:

- Designed for use at high temperatures
- Suitable for use with steam, oils, fuels, water, weak inorganic and organic acids, refrigerants and hydrocarbons
- Also available as Quantum FDA which is independently tested and certified with FDA approval and is suitable for use with food

Properties:

- Unique material bonded with HNBR
- Outstanding resistance to steam
- Available in sheet form and as cut gaskets
- WRAS approved for use in hot and cold potable water
- 3xA anti-stick finish on both sides

Typical Specifications:

Colour :	Beige both sides
Compressibility (ASTM F36J) :	10%
Recovery (ASTM F36J) :	60%
Stress relaxation (DIN 52913)	
50MPa, 16h/300°C :	28 N/mm ²
50MPa, 16h/175°C :	32 N/mm ²
Stress relaxation (BS 7531)	
40MPa, 16h/300°C :	27 N/mm ²
Klinger hot/cold compression	
Decrease in thickness at 23°C	10%
Decrease in thickness at 300°C	14%
Decrease in thickness at 400°C	20%
Tightness (DIN 28090-2) :	<0.02mg/(s.m)
Thickness increase after immersion in:	
Oil IRM 903, 5h/150°C	3%
Fuel B, 5h/23°C	5%
Density :	1.7g/cm ³

Tests and Certifications

- BS 7531 Grade AX
- Fire-safe (ISO 10497)
- DIN-DGVW
- BAM U W28 for use with oxygen 160 bar / 90°C
- TA-Luft (Clean Air) certificate acc. VDI 2440
- FDA Approval for Quantum FDA

Availability

- Sheetting (m): 2.0 x 1.5*, 4.0 x 1.5
- (* Denotes standard sheet size)
- Thickness (mm): 0.8, 1.0, 1.5, 2.0, 3.0

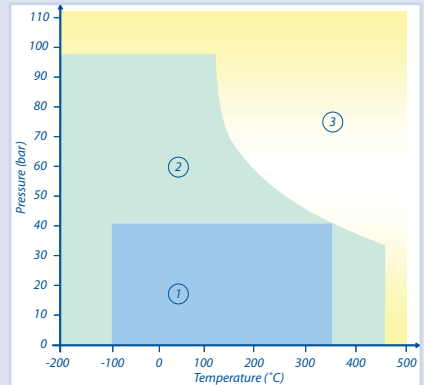
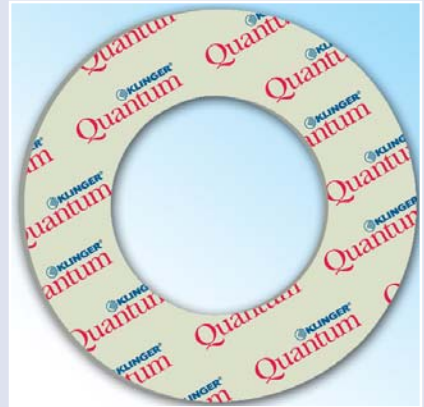

Pressure/Temperature Graph:

Area 1: Usually satisfactory to use without reference.
 Area 2: Usually satisfactory, but suggest you refer to Klinger for advice.
 Area 3: Caution: May be suitable but essential that you refer to Klinger for advice.

Sheet Material

KLINGERtop-sil-ML1



Introduction

KLINGERtop-sil-ML1 is a revolutionary multi-layered gasket material, based on a unique combination of synthetic fibres and special and standard elastomers, with outstanding resistance to ageing at high temperatures. The layers of the structure are characterised by the selection of elastomers. Since at least one of the layers contains a special elastomer, the decomposition and ageing processes associated with conventional fibre materials i.e., post curing, thermo-oxidative decomposition, degradation of the polymer chains etc. can be suppressed.

The multi-layer structure makes it possible to develop materials with new property profiles. The layers containing the special elastomers remain flexible over longer periods than standard materials, even at high temperatures, are therefore able to compensate for dynamic load fluctuations induced by the flange. This flexibility suppresses the creation of micro-crevices, which are responsible for gasket leakage. The layers containing standard elastomers are better able to resist deformation under load due to the formation of a denser network. The gasket remains flexible but still retains its strength.

Elastic Properties

A key property of a gasket material in steam systems is the ability to remain flexible over the service life of the joint. In order to assess this property, three point-bending test were performed on conditioned test specimens as follows:

Hot air for 168h at 160°C and saturated steam for 168h at 185°C

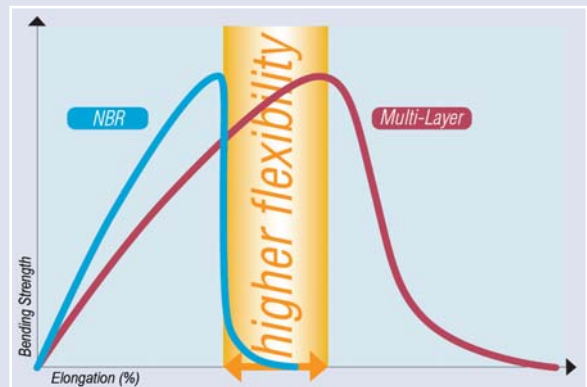

Tightness Behaviour in Steam

In order to assess the ageing resistance of the Multilayer material, the tightness behaviour in steam was assessed. The test conditions of 320°C and 120 bar pressure are extremely arduous for elastomer bound materials and are designed to promote rapid decomposition of the samples. As can be seen in the diagram below the Multi-layer material guarantees the user significantly lower emissions over a longer service life at elevated temperatures.

As shown in figure 1, the Multilayer material showed significantly improved flexibility compared with the conventional compressed fibre material. A more flexible gasket, which endures a deflection without breaking, will contribute to a safer and more reliable flange connection. The novel multi-layer structure significantly increases ageing resistance at elevated temperature when compared with conventional materials. With this concept, it is possible to minimise all the undesirable property changes associated with traditional compressed fibre materials such as embrittlement, formation of crevices and increased leakage.

Incorporation of special elastomers into separate layers within the multilayer structure ensures that a longer service life and increased temperature resistance can be expected.

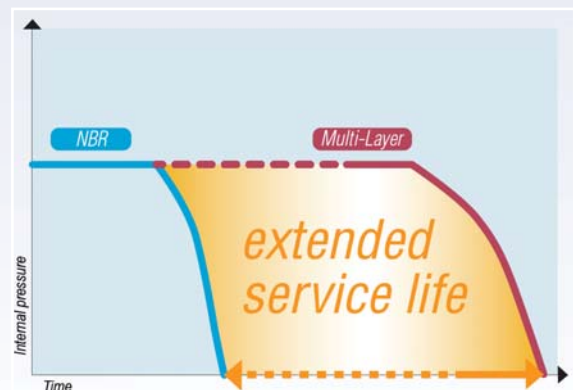

Top-Sil-ML1

Applications:

- Designed for high temperatures, steam, oils and hydrocarbons

Properties:

- Unique multilayer material designed for high temperature service.
- Outstanding resistance to steam.
- Available in sheet form and as cut gaskets
- Resistant to oils, fuels, hydrocarbons etc.
- WRAS approved for use in hot and cold potable water
- 3xA anti-stick finish on both sides

Typical Specifications:

Colour :	Yellow both sides
Compressibility (ASTM F36J) :	9%
Recovery (ASTM F36J) :	50%
Stress relaxation (DIN 52913)	
50MPa, 16h/300°C :	28 N/mm ²
50MPa, 16h/175°C :	34 N/mm ²
Klinger hot/cold compression	
Decrease in thickness at 23°C	8%
Decrease in thickness at 300°C	15%
Gas leakage (DIN 3535/6) :	<0.1ml/min
Thickness increase after immersion in:	
Oil IRM 903, 5h/150°C	4%
Fuel B, 5h/23°C	8%
Density :	1.7g/cm ³

Tests and Certifications

- BS 7531 Grade X
- WRAS Approval
- DIN-DGVW
- BAM U W28 for use with oxygen 160 bar / 80°C
- KTW
- Germanischer Lloyd
- TA-Luft (Clean Air) certificate acc. VDI 2440

Availability

- Sheeting (m): 2.0 x 1.5*, 4.0 x 1.5
- (* Denotes standard sheet size)
- Thickness (mm): 0.75, 1.0, 1.5, 2.0, 3.0

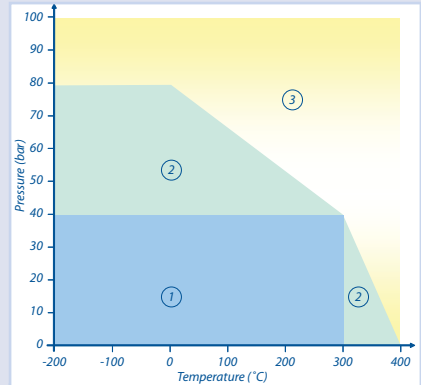

Pressure/Temperature Graph:

- Area 1: Usually satisfactory to use without reference.
- Area 2: Usually satisfactory, but suggest you refer to Klinger for advice.
- Area 3: Caution: May be suitable but essential that you refer to Klinger for advice.

KLINGERSIL

Sheet Material





Introduction

KLINGERSIL® is a range of specially formulated non-asbestos fibre based materials designed to meet the highest standards of performance for a wide range of industrial applications. Based on high performance inorganic or organic fibres blended with elastomeric compounds, KLINGERSIL® gaskets provide a long term sealing solution even under the most exacting operating conditions.

General Properties of KLINGERSIL® Materials

- Capable of sealing a wide range of industrial applications
- Easy to handle and install
- Excellent bolt stress retention properties
- Excellent sealing performance
- Easy to remove due to Klinger's proprietary anti-stick coating
- Economical

Applications (Dependent on grade)

- Temperatures from -196°C up to 400°C
- Pressures up to 100 bar
- Oils, solvents, gases, steam and many dilute acids and alkalis
- Controlled swell grades available for applications of low bolt load
- Food processing
- Potable water
- Automotive
- Valves and pumps

Options Available

- PTFE envelope and eyelet gaskets available
- KLINGERSIL C-4400 can be supplied in a colourless version, KLINGERSIL C-4400 L. The standard green and the colourless version are both KTW approved and are suitable for food processing operations.
- KLINGERSIL C-4430 and C-4500 can be supplied as K-versions for use in power stations. Their chloride and fluoride contents conform to the Siemens KWU standard.
- KLINGERSIL C4409 and C-4509 are reinforced with expanded metal made from carbon steel. Gaskets reinforced with stainless steel C-4409 L and C-4509 L are also available.

Glass fibre with NBR binder

Applications:

- Used for oil, steam, hydrocarbons, oxygen and potable water applications
- Premium quality material for many industrial sealing applications.
- Excellent resistance to hot water and steam.

Properties:

- Good steam resistance
- Resistant to oils, fuels, hydrocarbons etc.
- WRAS approved for use in hot and cold potable water
- Fire-safe
- Available in sheet form and as cut gaskets
- 3xA anti-stick finish on both sides

Typical Specifications:

Colour :	Green one side, white one side
Compressibility (ASTM F36J) :	9%
Recovery (ASTM F36J) :	50%
Stress relaxation	
DIN 52913: 50MPa, 16h/175°C :	39 N/mm ²
DIN 52913: 50MPa, 16h/300°C :	35 N/mm ²
BS 7531: 40MPa, 16h/300°C :	31 N/mm ²
Klinger hot/cold compression	
Decrease in thickness at 23°C	8%
Decrease in thickness at 300°C	11%
Gas leakage (DIN 3535/6) :	<0.1ml/min
Thickness increase after immersion in:	
Oil IRM 903, 5h/150°C	3%
Fuel B, 5h/23°C	5%
Density :	1.75g/cm ³
(Based on 2.0mm thick sample)	

Tests and Certifications:

- BS 7531 Grade X
- Fire-safe according to ISO 10497
- WRAS Approval
- DIN-DGVW
- BAM U W28 for use with oxygen 130bar / 90°C
- KTW
- Germanischer Lloyd
- TA-Luft (Clean Air) certificate acc. VDI 2440

Availability:

- Sheeting (m): 2.0 x 1.5*, 4.0 x 1.5, 2.0 x 2.0, 1.5 x 1.0
- (* Denotes standard sheet size)
- Thickness (mm): 0.25, 0.4, 0.5, 0.75, 1.0, 1.5, 2.0, 2.5, 3.0, 4.0
- Also available with reinforcements:
- KLINGERSIL C-4438, mild steel mesh

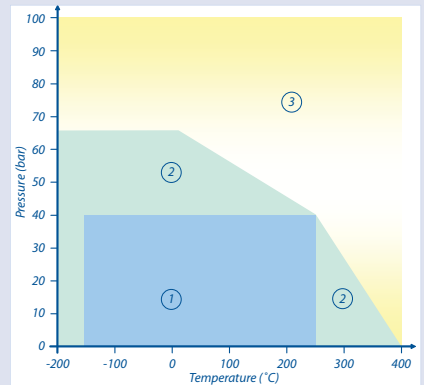

Pressure/Temperature Graph:

Area 1: Usually satisfactory to use without reference.
 Area 2: Usually satisfactory, but suggest you refer to Klinger for advice.
 Area 3: Caution: May be suitable but essential that you refer to Klinger for advice.

Sheet Material

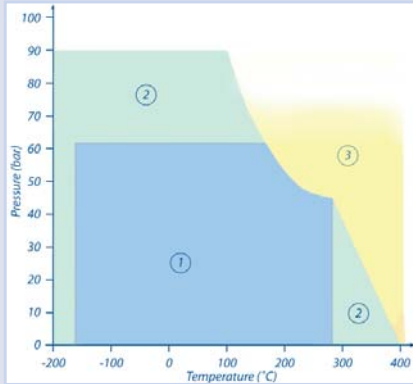

Pressure/Temperature Graph:

- Area 1: Usually satisfactory to use without reference.
- Area 2: Usually satisfactory, but suggest you refer to Klinger for advice.
- Area 3: Caution: May be suitable but essential that you refer to Klinger for advice.

Sheet Material

Glass fibre with NBR binder

Introduction:

Klingsil C-4430plus utilises the technology developed for the manufacture of Klinger Quantum to further improve upon the standard Klingsil C-4430 by increasing its maximum temperature. Klingsil C-4430plus also retains the outstanding compressive strength and stress retention capacity of Klingsil C-4430. C-4430plus can be used for temperatures up to 280°C.

Applications:

- Used for oil, steam, hydrocarbons, oxygen and potable water applications
- High pressure gasket for universal applications.
- Excellent resistance to water and steam at higher temperatures.

Properties:

- Good steam resistance
- Resistant to oils, fuels, hydrocarbons etc.
- WRAS approved for use in hot and cold potable water
- Fire-safe
- Available in sheet form and as cut gaskets
- 3xA anti-stick finish on both sides

Typical Specifications:

Colour : Red one side, white one side

Compressibility (ASTM F36J) : 9%

Recovery (ASTM F36J) : 50%

Stress relaxation

DIN 52913: 50MPa, 16h/175°C : 39 N/mm²

DIN 52913: 50MPa, 16h/300°C : 35 N/mm²

BS 7531: 40MPa, 16h/300°C : 31 N/mm²

Klinger hot/cold compression

Decrease in thickness at 23°C : 8%

Decrease in thickness at 300°C : 11%

Decrease in thickness at 400°C : 14%

Gas leakage (DIN 3535/6) : <0.1ml/min

Thickness increase after fluid immersion ASTM F146:

Oil IRM 903, 5h/150°C : 3%

Fuel B, 5h/23°C : 5%

Density : 1.75g/cm³

(Based on 2.0mm thick sample)

Tests and Certifications:

- BS 7531 Grade AX
- Fire-safe ISO 10497
- WRc/ WRAS Approval - IN PREPARATION
- DIN-DGVW
- DIN-DGVW W 270
- BAM U UVV 28 for use with oxygen
- KTW
- TA-Luft (Clean Air) certificate acc. VDI 2440

Availability:

- Sheetting (m): 1.0 x 1.5*, 2.0 x 1.5 (* Denotes standard sheet size)
- Thickness (mm): 0.5, 1.0, 1.5, 2.0, 3.0
- Also available in other thicknesses and sizes on request

Aramid fibre with NBR binder

Applications:

- Used for oil, steam, hydrocarbons, oxygen and water
- Premium quality material for many industrial sealing applications.
- Excellent resistance to hot water and steam.

Properties:

- Good resistance to oils, fuels, hydrocarbons
- Very successful in internal combustion engine applications
- Available in sheet form and as cut gaskets
- 3xA anti-stick finish on both sides

Typical Specifications:

Colour :	Green
Compressibility (ASTM F36J) :	11%
Recovery (ASTM F36J) :	55%
Stress relaxation (DIN 52913)	
DIN 52913: 50MPa, 16h/175°C :	32 N/mm ²
DIN 52913: 50MPa, 16h/300°C :	25 N/mm ²
BS 7531: 40MPa, 16h/300°C :	23 N/mm ²
Klinger hot/cold compression	
Decrease in thickness at 23°C	10%
Decrease in thickness at 300°C	20%
Gas leakage (DIN 3535/6) :	<0.02ml/min
Thickness increase after immersion in:	
Oil IRM 903, 5h/150°C	3%
Fuel B, 5h/23°C	5%
Thermal conductivity:	0.4-0.42W/mK
Density :	1.6g/cm ³
(Based on 2.0mm thick sample)	

Tests and Certifications:

- BS 7531 Grade Y
- BS F 130 Type A
- Fire-safe according to ISO 10497
- HTB
- DIN-DGVW
- BAM U W28 for use with oxygen 130bar/ 80 °C
- KTW
- Germanischer Lloyd
- TA-Luft (Clean Air) certificate acc. VDI 2440

Availability:

- Sheeting (m): 2.0 x 1.5*, 4.0 x 1.5, 2.0 x 2.0, 1.5 x 1.0
(* Denotes standard sheet size)
- Thickness (mm): 0.25, 0.4, 0.5, 0.75, 1.0, 1.5, 2.0, 2.5, 3.0, 4.0
- Also available with reinforcements:
- KLINGERSil C-4408, mild steel mesh

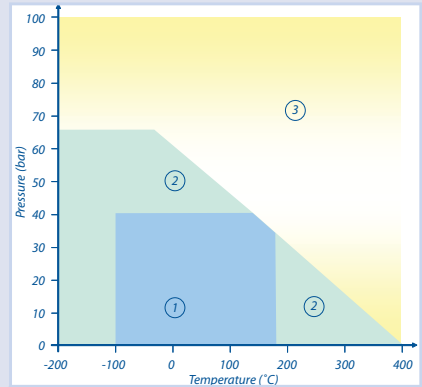

Pressure/Temperature Graph:

Area 1: Usually satisfactory to use without reference.
 Area 2: Usually satisfactory, but suggest you refer to Klinger for advice.
 Area 3: Caution: May be suitable but essential that you refer to Klinger for advice.

Sheet Material

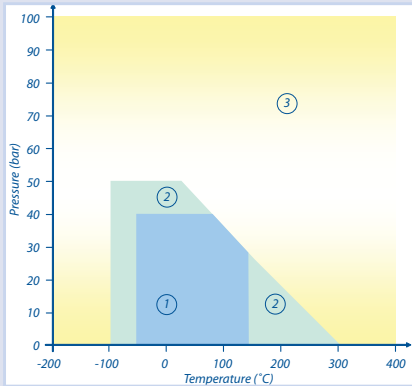

Pressure/Temperature Graph:

- Area 1: Usually satisfactory to use without reference.
- Area 2: Usually satisfactory, but suggest you refer to Klinger for advice.
- Area 3: Caution: May be suitable but essential that you refer to Klinger for advice.

Sheet Material

Aramid & Glass fibre with NBR binder

Applications:

- General service material suitable for a wide range of applications
- Used for oils, hydrocarbons, low-pressure steam and water applications.

Properties:

- Good resistance to oils, fuels, hydrocarbons
- An economic grade for general industrial services
- Available in sheet form and as cut gaskets
- 3xA anti-stick finish on both sides

Typical Specifications:

Colour :	Green one side, black one side
Compressibility (ASTM F36J) :	12%
Recovery (ASTM F36J) :	55%
Stress relaxation	
DIN 52913: 50MPa, 16h/300°C :	20 N/mm ²
BS 7531: 40MPa, 16h/300°C :	23 N/mm ²
Klinger hot/cold compression	
Decrease in thickness at 23°C	10%
Decrease in thickness at 300°C	25%
Gas leakage (DIN 3535/6) :	<0.1ml/min
Thickness increase after immersion in:	
Oil IRM 903, 5h/150°C	0-5%
Fuel B, 5h/23°C	0-10%
Density :	1.85g/cm ³
(Based on 2.0mm thick sample)	

Tests and Certifications:

- BS 7531 Grade Y
- DIN-DGVW
- KTW
- WRAS Approved
- Germanischer Lloyd

Availability:

- Sheetting (m): 2.0 x 1.5*, 4.0 x 1.5, 1.5 x 1.0
- (* Denotes standard sheet size)
- Thickness (mm): 0.4, 0.5, 0.75, 1.0, 1.5, 2.0, 3.0

Carbon fibre with NBR binder

Applications:

- Used in a wide range of media including oils, hydrocarbons, alkalis and steam
- Carbon-fibre reinforcement greatly improves chemical resistance in alkaline services

Properties:

- Good resistance to steam
- Good resistance to alkaline applications
- Excellent load-bearing characteristics
- Good resistance to oils, fuels, hydrocarbons
- Available in sheet form and as cut gaskets
- 3xA anti-stick finish on both sides

Typical Specifications:

Colour :	Black
Compressibility (ASTM F36J) :	12%
Recovery (ASTM F36J) :	60%
Stress relaxation	
DIN 52913: 50MPa, 16h/300°C :	35 N/mm ²
DIN 52913: 50MPa, 16h/300°C :	32 N/mm ²
BS 7531: 40MPa, 16h/300°C :	30 N/mm ²
Klinger hot/cold compression	
Decrease in thickness at 23°C	10%
Decrease in thickness at 300°C	15%
Gas leakage (DIN 3535/6) :	<1.0ml/min
Thickness increase after immersion in:	
Oil IRM 903, 5h/150°C	3%
Fuel B, 5h/23°C	5%
Density :	1.6g/cm ³
(Based on 2.0mm thick sample)	

Tests and Certifications:

- BS 7531 Grade X
- Firesafe API 6 FA, DIN ISO 10497
- DIN-DGVW
- BAM U W28 for use with oxygen 160 bar / 85°C
- KTW
- Germanischer Lloyd
- TA-Luft (Clean Air) certificate acc. VDI 2440

Availability:

- Sheeting (m): 2.0 x 1.5*, 4.0 x 1.5, 1.5 x 1.0
(* Denotes standard sheet size)
- Thickness (mm): 0.4, 0.5, 0.75, 1.0, 1.5, 2.0, 3.0
- Available with expanded steel reinforcement : C-4509
- Available with stainless steel reinforcement : C-4509L

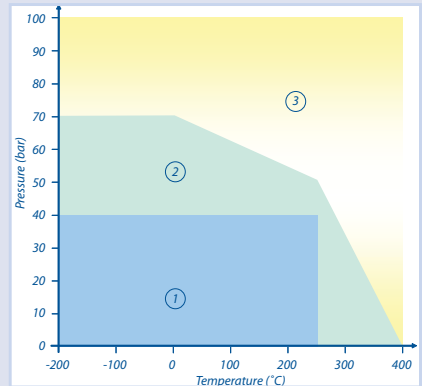

Pressure/Temperature Graph:

Area 1: Usually satisfactory to use without reference.
 Area 2: Usually satisfactory, but suggest you refer to Klinger for advice.
 Area 3: Caution: May be suitable but essential that you refer to Klinger for advice.

Sheet Material

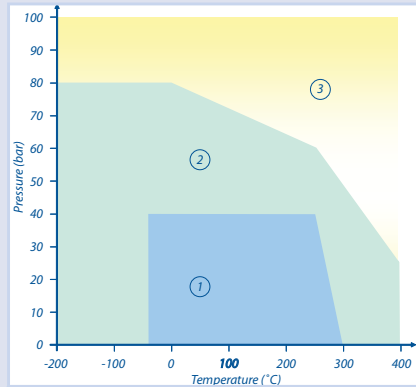

Pressure/Temperature Graph:

Area 1: Usually satisfactory to use without reference.
 Area 2: Usually satisfactory, but suggest you refer to Klinger for advice.
 Area 3: Caution: May be suitable but essential that you refer to Klinger for advice.

Sheet Material

Carbon fibre with NBR binder and expanded metal reinforcing insert

Applications:

- Used in a wide range of media including oils, hydrocarbons, alkalis and steam
- Carbon-fibre reinforcement greatly improves chemical resistance in alkaline services
- Applications where a high-strength, high-integrity seal is required.

Properties:

- Top quality KLINGERSIL grade based on carbon fibre with a nitrile rubber binder with an expanded steel reinforcement.
- Excellent load-bearing characteristics.
- A premium quality sealing material with outstanding resistance to alkaline media and steam.
- Available in sheet form and as cut gaskets
- 3xA anti-stick finish on both sides

Typical Specifications:

Colour :	Black
Compressibility (ASTM F36J) :	12%
Recovery (ASTM F36J) :	70%
Stress relaxation	
DIN 52913: 50MPa, 16h/300°C :	39 N/mm ²
Klinger hot/cold compression	
Decrease in thickness at 23°C	9%
Decrease in thickness at 300°C	7%
Thickness increase after immersion in:	
Oil IRM 903, 5h/150°C	3%
Fuel B, 5h/23°C	5%
Density :	2.0g/cm ³
(Based on 2.0mm thick sample)	

Tests and Certifications:

- Germanischer Lloyd

Availability:

- Sheeting (m): 2.0 x 1.5*, 4.0 x 1.5, 1.5 x 1.0 (* Denotes standard sheet size)
- Thickness (mm): 0.4, 0.5, 0.75, 1.0, 1.5, 2.0, 3.0
- Available with stainless steel reinforcement : C-4509L

Glass fibre with Hypalon™ binder

Applications:

- Used in a wide range of chemicals including many acids and alkalis, oils and fuels.
- Specialist grade designed for use with acids.
- Resistant to sulphuric and hydrofluoric acid.

Properties:

- Resistant to most mineral acids
- Resistant to alkalis, ketones and aldehydes
- Resistant to many refrigerants
- Resistant to oils, fuels, hydrocarbons etc.
- Available in sheet form and as cut gaskets
- 3xA anti-stick finish on both sides

Typical Specifications:

Colour :	Off-white
Compressibility (ASTM F36J) :	9%
Recovery (ASTM F36J) :	55%
Klinger hot/cold compression	
Decrease in thickness at 23°C	7%
Decrease in thickness at 200°C	17%
Thickness increase after immersion in:	
Sulphuric acid 65%, 48h/25°C	8%
Sulphuric acid 96%, 18h/25°C	10%
Nitric acid 96%, 18h/25°C	Unsuitable
Density :	1.7g/cm ³

(Based on 2.0mm thick sample)

Tests and Certifications:

- BS 7531 Grade Y
- Germanischer Lloyd
- TÜV Poland
- TA-Luft (Clean Air) certificate acc. VDI 2440

Availability:

- Sheeting (m): 2.0 x 1.5*, 4.0 x 1.5, 2.0 x 2.0, 1.5 x 1.0 (* Denotes standard sheet size)
- Thickness (mm): 0.5, 0.75, 1.0, 1.5, 2.0, 3.0

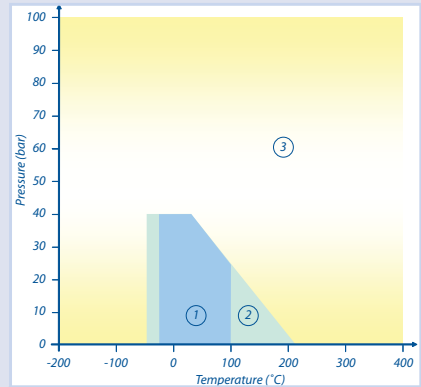

Pressure/Temperature Graph:

Area 1: Usually satisfactory to use without reference.
 Area 2: Usually satisfactory, but suggest you refer to Klinger for advice.
 Area 3: Caution: May be suitable but essential that you refer to Klinger for advice.

Sheet Material

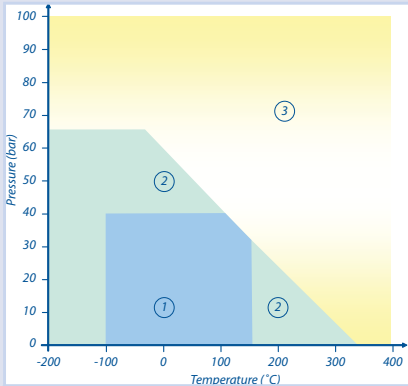

Pressure/Temperature Graph:

- Area 1: Usually satisfactory to use without reference.
- Area 2: Usually satisfactory, but suggest you refer to Klinger for advice.
- Area 3: Caution: May be suitable but essential that you refer to Klinger for advice.

Sheet Material

Aramid fibre with SBR/NR binder

Applications:

- Specifically designed for automotive applications
- Oils and water and where bolt load is limited.

Properties:

- Premium grade, controlled-swell material.
- Available in sheet form and as cut gaskets
- 3xA anti-stick finish on both sides

Typical Specifications:

Colour :	Fawn
Compressibility (ASTM F36J) :	8-10%
Recovery (ASTM F36J) :	>55%
Stress relaxation	
DIN 52913: 50MPa, 16h/300°C :	25 N/mm ²
Klinger hot/cold compression	
Decrease in thickness at 23°C :	10%
Decrease in thickness at 300°C :	18%
Gas leakage (DIN 3535/6) :	<0.5ml/min
Thickness increase after immersion in:	
Oil IRM 903, 5h/150°C	20%
Fuel B, 5h/23°C	20%
Density :	1.7g/cm ³
(Based on 2.0mm thick sample)	

Tests and Certifications:

- BS 7531 Grade Y
- Germanischer Lloyd

Availability:

- Sheeting (m): 2.0 x 1.5*, 4.0 x 1.5, 2.0 x 2.0, 1.5 x 1.0
- (* Denotes standard sheet size)
- Thickness (mm): 0.5, 1.0, 1.5, 2.0, 3.0

Synthetic fibre & cork blend with NBR binder

Applications:

- This special material is particularly useful in applications where light loadings or uneven flanges are involved
- Used for oils, water and where bolt load is limited

Properties:

- Excellent sealability even at low bolt loads
- Economical
- Good resistance to oils, fuels, hydrocarbons, water etc
- Excellent gas leakage properties
- Available in sheet form and as cut gaskets
- 3xA anti-stick finish on both sides

Typical Specifications:

Colour :	Light brown
Compressibility (ASTM F36J) :	30%
Recovery (ASTM F36J) :	50%
Stress relaxation	
DIN 52913: 25MPa, 16h/100°C :	15 N/mm ²
Klinger hot/cold compression	
Decrease in thickness at 23°C	16%
Decrease in thickness at 200°C	22%
Gas leakage (DIN 3535/6) :	<0.1ml/min
Thickness increase after immersion in:	
Oil IRM 903, 5h/150°C	5%
Fuel B, 5h/23°C	7%
Density :	1.0g/cm ³
(Based on 2.0mm thick sample)	

Availability:

- Sheeting (m): 2.0 x 1.5
- Thickness (mm): 0.5, 1.0, 1.5, 2.0, 3.0

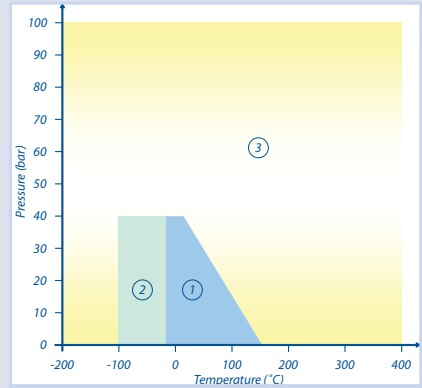

Pressure/Temperature Graph:

Area 1: Usually satisfactory to use without reference.
 Area 2: Usually satisfactory, but suggest you refer to Klinger for advice.
 Area 3: Caution: May be suitable but essential that you refer to Klinger for advice.

Sheet Material

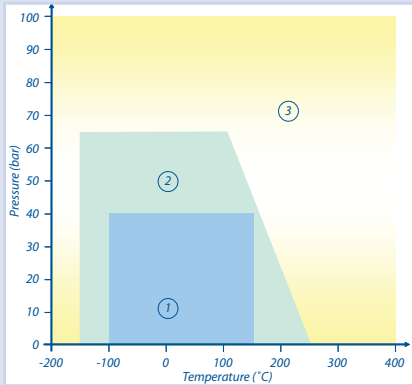

Pressure/Temperature Graph:

Area 1: Usually satisfactory to use without reference.
 Area 2: Usually satisfactory, but suggest you refer to Klinger for advice.
 Area 3: Caution: May be suitable but essential that you refer to Klinger for advice.

Sheet Material

Mineral fibre with NBR binder

Applications:

- Specially designed for use with reffridgerants
- Excellent sealability even at low bolt loads

Properties:

- Premium, highly compressible grade
- Available in sheet form and as cut gaskets
- 3xA anti-stick finish on both sides

Typical Specifications:

Colour :	Blue
Compressibility (ASTM F36J) :	26%
Recovery (ASTM F36J) :	>50%
Klinger hot/cold compression	
Decrease in thickness at 23°C :	12%
Decrease in thickness at 200°C :	15%
Thickness increase after immersion in:	
Oil IRM 903, 5h/150°C	<10%
Fuel B, 5h/23°C	<15%
Density :	1.6g/cm ³
(Based on 2.0mm thick sample)	

Availability:

- Sheeting (m): 2.0 x 1.5
- Thickness (mm): 0.5, 0.8, 1.0, 1.5

Top-Graph 2000





Introduction

KLINGERtop-graph-2000 is a compressed graphite sheet material reinforced with non-asbestos fibre. Manufactured using a revolutionary process, the material offers outstanding sealing performance in a wide range of service conditions including gases, hydrocarbons, refrigerants and steam.

The material has excellent mechanical properties with high load bearing capacity and excellent stress relaxation properties, allowing the material to be used at higher temperatures and pressures than normally associated with the compressed non-asbestos fibre materials.

The high graphite content of KLINGERtop-graph 2000 provides the material with a high degree of flexibility and, since it does not require metallic reinforcements, it is easy to handle and cut - even on-site.

General Properties

- Capable of sealing a wide range of industrial applications
- Easy to handle
- Easy to cut
- Excellent steam resistance.
- Good gas tightness properties
- Anti-stick coating
- Economical

Applications

- Temperatures from -196°C up to 400°C
- Pressures up to 100 bar
- Oils, solvents, gases, steam and most dilute acids and alkalis
- Automotive
- Valves and pumps

Glass fibre with graphite and NBR binder

Applications:

- Used for oil, steam, hydrocarbons, oxygen and water applications
- Premium quality material for many industrial sealing applications
- Excellent resistance to hot water and steam.

Properties:

- A combination of expanded graphite and synthetic fibres to give a revolutionary sealing material with outstanding flexibility and excellent stability in steam
- Resistant to oils, fuels, hydrocarbons etc.
- Easy to handle and cut
- Good leakage properties
- Available in sheet form and as cut gaskets
- 3xA anti-stick finish on both sides

Typical Specifications:

Colour :	Grey
Compressibility (ASTM F36J) :	10%
Recovery (ASTM F36J) :	60%
Stress relaxation	
DIN 52913: 50MPa, 16h/300°C :	35 N/mm ²
Klinger hot/cold compression	
Decrease in thickness at 23°C	10%
Decrease in thickness at 300°C	10%
Gas leakage (DIN 3535/6) :	<0.5ml/min
Thickness increase after immersion in:	
Oil IRM 903, 5h/150°C	5%
Fuel B, 5h/23°C	7%
Density :	1.75g/cm ³
(Based on 2.0mm thick sample)	

Tests and Certifications:

- BS 7531 Grade X
- DIN-DGVW
- BAM UVV28 for use with oxygen up to 130 bar / 95°C
- KTW Approved
- SVGW 92-149-7
- Germanischer Lloyd 47-710 – 03 HH
- TA-Luft (Clean Air) certificate acc. VDI 2440

Availability:

- Sheeting (m): 2.0 x 1.5*, 4.0 x 1.5, 2.0 x 2.0, 1.5 x 1.0 (* Denotes standard sheet size)
- Thickness (mm): 0.5, 0.75, 1.0, 1.5, 2.0, 3.0
- Also available with reinforcements:
KLINGER[®]top-graph-2009, expanded steel mesh

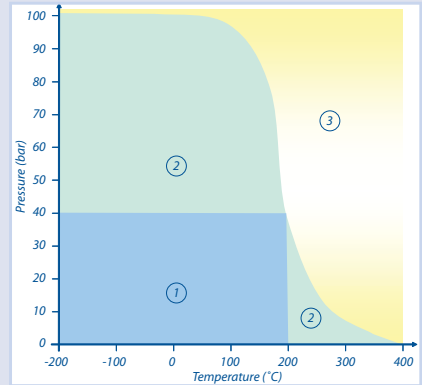

Pressure/Temperature Graph:

Area 1: Usually satisfactory to use without reference.
 Area 2: Usually satisfactory, but suggest you refer to Klinger for advice.
 Area 3: Caution: May be suitable but essential that you refer to Klinger for advice.

Sheet Material

Graphite

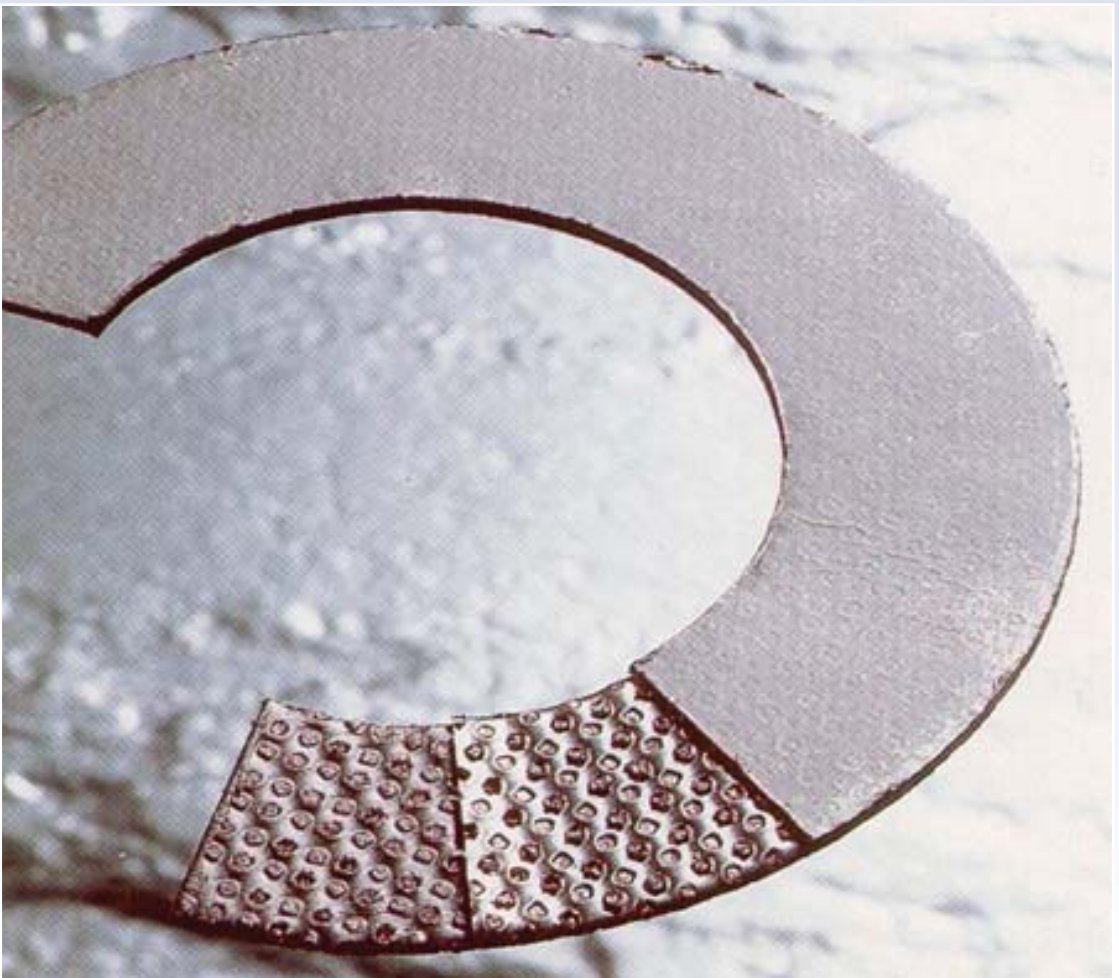

Introduction

Klinger flexible graphite materials are universal sealing products consisting of pure carbon in which the crystalline structure has been considerably expanded through a special chemical and thermal procedure. The expanded crystals are formed into foil by a multi-stage calendering process. The thin flexible graphite foil can then be laminated into thicker sheets to manufacture a range of sealing products.

Klinger flexible graphite sheet can also be supplied with reinforcing materials to increase the tensile strength, load-bearing capacity and improve handling characteristics. Laminated graphite sheet materials such as PSM-AS are often used as a replacement for asbestos-based materials owing to their excellent chemical resistance and temperature.



An expanded graphite flake

Graphite laminate materials are ideal for steam applications as they do not contain a rubber binder and are not subjected to hardening of the material.

General Properties

- Outstanding resistance to high and low temperature
- Chemically resistant to virtually all media
- High compressibility
- Low creep under temperature or pressure
- Seals gases and liquids effectively at low bolt loadings
- Unlimited storage life

KLINGERgraphite-laminate TSM

A recent addition to the Klinger range is Klinger TSM, specially developed to improve sealing properties when used with low gasket stresses and meet the requirements for applications to the German clean air act (TA-Luft). TSM has been tested and certified to meet the criteria of VDI 2440 at 300°C

Applications

- High and low temperatures
- Aggressive media
- Low bolt loads
- Sealing of damaged flange surfaces
- Hot oil equipment
- Liquid gas plants
- Heat exchangers
- Nuclear power plants
- Cylinder head and manifold gaskets for engines and compressors

Reinforcements available

- Tanged Stainless steel 316 *
- Stainless steel 316 foil *
- Tanged Hastelloy B2
- Nickel foil
- Polyester foil
- Other inserts are available on request.

* Denotes standard materials

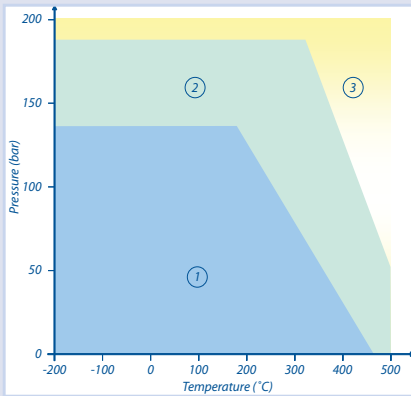
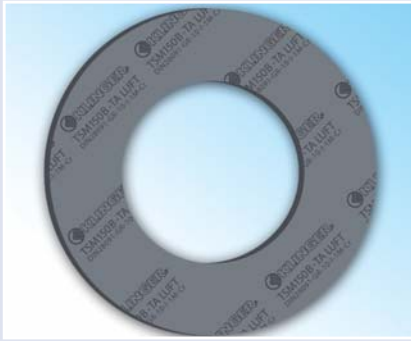

Pressure/Temperature Graph:

- Area 1: Usually satisfactory to use/mark.
- Area 2: Usually satisfactory, but suggest you refer to Klinger for advice.
- Area 3: Caution: May be suitable but essential that you refer to Klinger for advice.

TA-Luft approved exfoliated graphite with tanged insert

Applications:

- For applications requiring a material with TA-Luft approval.
- Used for a wide range of industrial sealing applications including steam, hot water, thermal oils and hydrocarbons
- Premium quality material for many industrial sealing applications.
- Excellent resistance to hot water and steam.

Properties:

- Excellent gas-tightness even at low gasket stresses.
- Excellent resistance to steam
- Resistant to virtually all media
- Outstanding resistance to high and low temperature
- Maximum temp. 460°C (in oxidising atmospheres) 3000°C (in non-oxidising atmospheres)
- High compressibility
- Good leakage properties
- Unlimited storage life
- Available in sheet form and as cut gaskets
- TA-Luft approval
- Anti-stick finish on both sides

Typical Specifications:

Colour :	Grey
Compressibility (ASTM F36J) :	30-45%
Recovery (ASTM F36J) :	15-25%
Stress relaxation	
DIN 52913: 50MPa, 16h/300°C :	>45 N/mm ²
Leachable chloride :	>40ppm
Graphite purity :	>98%
Insert :	316, 0.1mm
Density :	1.0g/cm ³

(Based on 1.5mm thick sample)

Tests and Certifications:

- TA-Luft (Clean Air) certificate acc. VDI 2440
- Other tests in preparation

Availability:

- Sheeting (m): 1.0 x 1.0*, 1.5 x 1.5
(* Denotes standard sheet size)
- Thickness (mm): 0.8, 1.0, 1.5, 2.0, 3.0
- Also available with re-inforcements:
 - KLINGER PSM-AS, tanged stainless steel insert (shown on page 143)
 - KLINGER SLS, stainless steel foil (shown on page 144)
 - KLINGER SLN, with Nickel foil insert
 - KLINGER SML, with polyester insert

Exfoliated graphite with tanged insert

Applications:

- Used for a wide range of industrial sealing applications including steam, hot water, thermal oils and hydrocarbons
- Premium quality material for many industrial sealing applications.
- Excellent resistance to hot water and steam.

Properties:

- Excellent resistance to steam
- Resistant to virtually all media
- Outstanding resistance to high and low temperature
- Maximum temp. 460°C (in oxidising atmospheres) 3000°C (in non-oxidising atmospheres)
- High compressibility
- Good leakage properties
- Unlimited storage life
- Available in sheet form and as cut gaskets
- Anti-stick finish on both sides

Typical Specifications:

Colour :	Grey
Compressibility (ASTM F36J) :	35%
Recovery (ASTM F36J) :	20%
Stress relaxation	
DIN 52913: 50MPa, 16h/300°C :	48 N/mm ²
BS 7531: 40MPa, 16h/300°C :	38 N/mm ²
Leachable chloride :	40ppm
Graphite purity :	>98%
Insert :	316, 0.1mm
Gas leakage (DIN 3535/6) :	<1.0ml/min
Thickness increase after immersion in	
Oil IRM 903, 5h/150°C :	<2%
Density :	1.0g/cm ³
(Based on 1.5mm thick sample)	

Tests and Certifications:

- Fire-safe API 6FB
- WRAS Approval
- DIN-DGVW
- BAM U W28 for use with oxygen 130 bar / 200°C
- KTW
- Germanischer Lloyd

Availability:

- Sheeting (m): 1.0 x 1.0*, 1.5 x 1.5
- (* Denotes standard sheet size)
- Thickness (mm): 0.8, 1.0, 1.5, 2.0, 3.0
- Also available with re-inforcements:
 - KLINGER SLS, stainless steel foil (shown on page 144)
 - KLINGER SLN, with Nickel foil insert
 - KLINGER SML, with polyester insert

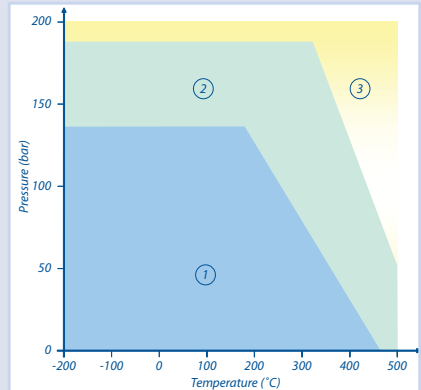
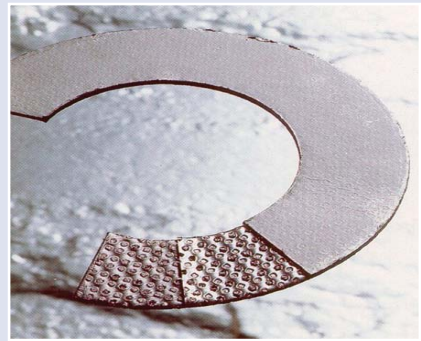

Pressure/Temperature Graph:

- Area 1: Usually satisfactory to use without reference.
- Area 2: Usually satisfactory, but suggest you refer to Klinger for advice.
- Area 3: Caution: May be suitable but essential that you refer to Klinger for advice.

Sheet Material

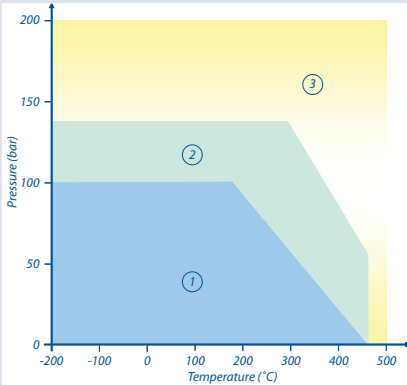
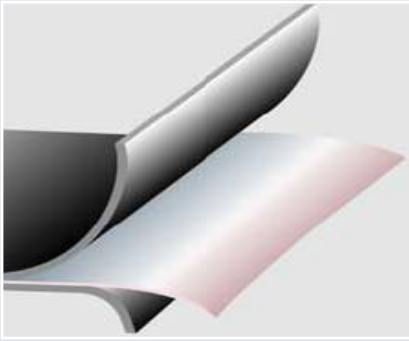

Pressure/Temperature Graph:

Area 1: Usually satisfactory to use without reference.
 Area 2: Usually satisfactory, but suggest you refer to Klinger for advice.
 Area 3: Caution: May be suitable but essential that you refer to Klinger for advice.

Sheet Material

Exfoliated graphite with foil insert

Applications:

- Used for a wide range of industrial sealing applications including steam, hot water, thermal oils and hydrocarbons
- Premium quality material for many industrial sealing applications.
- Excellent resistance to hot water and steam.

Properties:

- Excellent resistance to steam
- Resistant to virtually all media
- Outstanding resistance to high and low temperature
- Maximum temperature 460°C (in oxidising atmospheres) 3000°C (in non-oxidising atmospheres)
- High compressibility
- Good leakage properties
- Unlimited storage life
- Available in sheet form and as cut gaskets
- Anti-stick finish on both sides

Typical Specifications:

Colour :	Grey
Compressibility (ASTM F36J) :	40%
Recovery (ASTM F36J) :	15%
Stress relaxation	
DIN 52913: 50MPa, 16h/300°C :	48 N/mm ²
BS 7531: 40MPa, 16h/300°C :	38 N/mm ²
Leachable chloride :	40ppm
Graphite purity :	>98%
Insert :	316, 0.05mm
Gas leakage (DIN 3535/6) :	<1.0ml/min
Thickness increase after immersion in	
Oil IRM 903, 5h/150°C :	<2%
Density :	1.0g/cm ³
(Based on 1.5mm thick sample)	

Tests and Certifications:

- WRAS Approval
- DIN-DGVW
- BAM U W28 for use with oxygen 130bar / 200°C
- KTW
- Germanischer Lloyd

Availability:

- Sheeting (m): 1.0 x 1.0*, 1.5 x 1.5
 (* Denotes standard sheet size)
- Thickness (mm): 0.45, 0.8, 1.0, 1.5, 2.0, 3.0
- Also available with other re-inforcements:
 KLINGER PSM-AS, stainless steel insert (shown on page 143)
 KLINGER SLN, with Nickel foil insert
 KLINGER SML, with polyester insert

Exfoliated graphite with tanged insert and eyelet

Applications:

- Used for a wide range of industrial sealing applications including steam, hot water, thermal oils and hydrocarbons

Properties:

- Excellent resistance to chemicals and high-temperatures
- Protects gasket inner edge against polymerisation and chemical attack
- Reduced potential for process contamination
- Excellent handling characteristics
- Improved blow out resistance
- "Anti-stick" finish

Typical Specifications:

Colour :	Grey
Compressibility (ASTM F36J) :	35%
Recovery (ASTM F36J) :	20%
Stress relaxation	
DIN 52913: 50MPa, 16h/300°C :	48 N/mm ²
Graphite purity :	>98%
Insert :	316, 0.1mm
Gas leakage (DIN 3535/6) :	<0.5ml/min

Availability:

- Thickness (mm): 0.45, 0.8, 1.0, 1.5, 2.0, 3.0
- Also available with other reinforcements:
 KLINGER SLS-AS, stainless steel insert (shown on page 143)
 KLINGER SLN, with Nickel foil insert
 KLINGER SML, with polyester insert

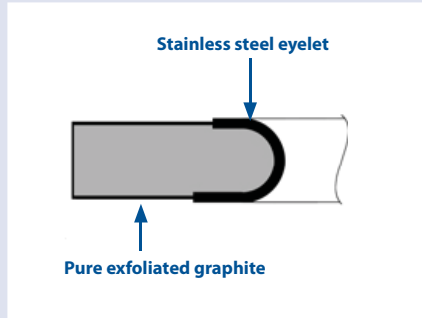

Sheet Material

Top-Chem





Klinger Top-Chem

KLINGERTop-chem is a range of modified PTFE based materials which offer the chemical resistance of PTFE with increased mechanical strength and resistance to cold and hot flow under compressive loading. Additional compounds such as silica, barium sulphate or silicon carbide allow the materials to be used at higher temperatures and compressive loads than would typically be expected for standard PTFE products.

KLINGERTop-chem-2000

KLINGERTop-chem-2000 is a heavy-duty modified PTFE material, which has been engineered to cater for a wide range of applications. The exceptional mechanical strength of the material enables it to withstand high temperatures and pressures, whilst providing unparalleled creep-resistance. This material has excellent chemical resistance and can be used in strongly acidic and alkaline applications. It is the only PTFE based material with fire-safe certification (EN 10497 & API 6FA).

KLINGERTop-chem-2003

KLINGERTop-chem-2003 has been designed to offer high compressibility combined with outstanding chemical resistance. The result is a material which is suitable for practically all media including both strongly acidic and strongly alkaline environments and which is able to maintain a tight seal even at low bolt loads. The highly compressible nature of KLINGERTop-chem-2003 allows the material to be used on glass and rubber lined flanges. The material has excellent mechanical properties at low and medium temperatures and loads.

KLINGERTop-chem-2005 and 2006

KLINGERTop-chem-2005 and 2006 have been developed to offer an economical alternative to KLINGERTop-chem-2000 and KLINGERTop-chem-2003 for less demanding applications. Both materials offer good mechanical properties for medium and low temperatures and loads.

KLINGERTop-chem-2006 is also free from pigments and is therefore especially suited to food and pharmaceutical applications.

Summary of material properties

Material	Top-Chem-2000	Top-Chem-2003	Top-Chem-2005	Top-Chem-2006
Strong acids	✓✓	✓✓	✓✓	✓
Strong Alkalis	✓✓	✓✓	✓	✓✓
Mechanical resistance to high temperature	✓✓	✗	✓	✓
Tightness	✓	✓✓	✓	✓
Adaptability	✗	✓✓	✓	✓

Sheet Material

Premium grade, heavy-duty modified PTFE

Applications:

- Virtually all media up to temperatures of 260°C
- Ideal for aggressive chemicals, steam and oxygen applications
- Excellent resistance to biofuels offering a fire-safe gasket suitable for all concentrations

Properties:

- Premium grade, heavy-duty PTFE gasket suitable for a wide range of applications within the chemical and petrochemical industries
- The only PTFE based gasket material on the market to hold fire-safe approval
- Excellent sealing at high temperatures and pressures
- Ideal for aggressive chemicals
- Easy to handle and cut
- Fire-safe
- Creep resistant
- Available in sheet form and as cut gaskets
- Anti-stick finish on both sides

Typical Specifications:

Colour :	Grey
Compressibility (ASTM F36J) :	2%
Recovery (ASTM F36J) :	55%
Stress relaxation	
DIN 52913: 30MPa, 16h/150°C :	28 N/mm ²
DIN 52913: 50MPa, 16h/300°C :	35 N/mm ²
Klinger hot/cold compression	
Decrease in thickness at 23°C	2%
Decrease in thickness at 250°C	5%
Gas leakage (DIN 3535/6) :	<0.5ml/min
Thickness increase after immersion in:	
H ₂ SO ₄ 100%, 18h/23°C	1%
HNO ₃ 100%, 18h/23°C	1%
NaOH 33%, 72h/110°C	1%
Density :	2.5g/cm ³
(Based on 1.5mm thick sample)	

Tests and Certifications:

- Fire-safe to ISO EN 10497 & API 6FA
- BAM Approval for use with oxygen 100 bar / 200°C
- KTW Approval
- DIN DVGW
- FDA Conformity
- TA Luft Approval
- Germanischer Lloyd
- United States Coast Guard
- Italiano Navale
- Det Norske Veritas

Availability:

- Sheetting (m): 1.5 x 1.5
- Thickness (mm): 1.0, 1.5, 2.0, 3.0

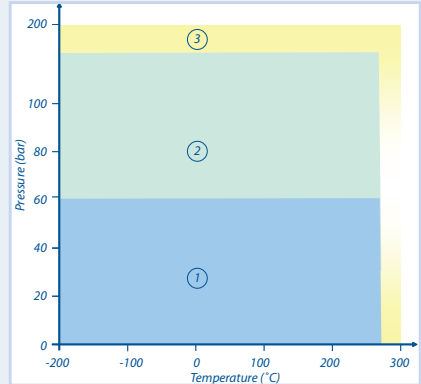
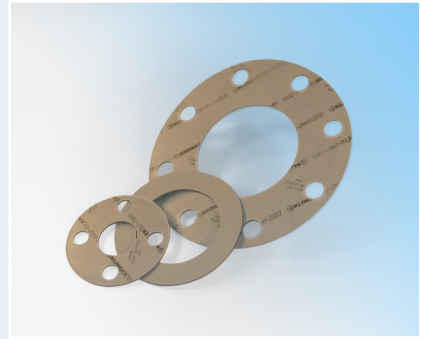

Pressure/Temperature Graph:

Area 1: Usually satisfactory to use without reference.
 Area 2: Usually satisfactory, but suggest you refer to Klinger for advice.
 Area 3: Caution: May be suitable but essential that you refer to Klinger for advice.

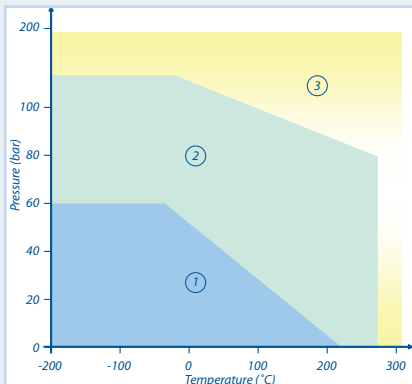

Pressure/Temperature Graph:

Area 1: Usually satisfactory to use without reference.
 Area 2: Usually satisfactory, but suggest you refer to Klinger for advice.
 Area 3: Caution: May be suitable but essential that you refer to Klinger for advice.

Sheet Material

Premium grade, high compressibility modified PTFE

Applications:

- Virtually all media up to temperatures of 260°C
- Excellent sealing performance at low surface stress and is especially suitable for use in glass and rubber lined flanges
- Ideal for aggressive chemicals, steam and oxygen applications.

Properties:

- Highly compressible, modified PTFE material with outstanding chemical resistance. Ideal for applications where bolt load is limited or where flanges are delicate e.g. glass-lined equipment
- Excellent chemical resistance
- Excellent sealability even at low bolt loads or temperatures
- Ideal for non-metallic flanges and damaged sealing surfaces
- Available in sheet form and as cut gaskets
- Anti-stick finish on both sides

Typical Specifications:

Colour :	Beige
Compressibility (ASTM F36J) :	16%
Recovery (ASTM F36J) :	35%
Stress relaxation	
DIN 52913: 30MPa, 16h/150°C :	13 N/mm ²
Klinger hot/cold compression	
Decrease in thickness at 23°C, 25MPa	9%
Decrease in thickness at 250°C, 25MPa	38%
Gas leakage (DIN 3535/6) :	<0.1ml/min
Thickness increase after immersion in:	
H ₂ SO ₄ , 100%, 18h/230°C	1%
HNO ₃ , 100%, 18h/23°C	0%
NaOH, 33%, 72h/110°C	1%
Density :	1.7g/cm ³
(Based on 2.0mm thick sample)	

Tests and Certifications:

- BAM Approval for use with oxygen 20 bar / 60°C
- KTW Approval
- DIN DVGW
- FDA Conformity
- Germanischer Lloyd
- TA Luft Approval

Availability:

- Sheetting (m): 1.5 x 1.5
- Thickness (mm): 1.0, 1.5, 2.0, 3.0

Economical, modified PTFE

Applications:

- Ideal for strongly acidic environments
- Modified PTFE material with excellent chemical resistance and good mechanical properties. Suitable for a wide range of applications with the exception of strong alkaline conditions
- Ideal for aggressive chemicals, steam and oxygen applications.

Properties:

- Economical alternative to Top-Chem-2000
- Good mechanical properties at low to medium temperatures
- Very good chemical resistance
- Available in sheet form and as cut gaskets
- Anti-stick finish on both sides

Typical Specifications:

Colour :	Brick red
Compressibility (ASTM F36J) :	3%
Recovery (ASTM F36J) :	40%
Stress relaxation	
DIN 52913: 30MPa, 16h/150°C :	25 N/mm ²
Klinger hot/cold compression	
Decrease in thickness at 23°C, 50MPa	10%
Decrease in thickness at 250°C, 50MPa	30%
Gas leakage (DIN 3535/6) :	<0.2ml/min
Thickness increase after immersion in:	
H ₂ SO ₄ , 100%, 18h/230°C	1%
HNO ₃ , 100%, 18h/23°C	1%
NaOH, 33%, 72h/110°C	Not Suitable
Density :	2.2g/cm ³
(Based on 1.5mm thick sample)	

Tests and Certifications:

- BAM Approval for use with oxygen 100 bar / 200°C
- KTW Approval
- DIN DVGW
- FDA Conformity
- Germanischer Lloyd
- TA Luft Approval

Availability:

- Sheeting (m): 1.5 x 1.5
- Thickness (mm): 1.0, 1.5, 2.0, 3.0

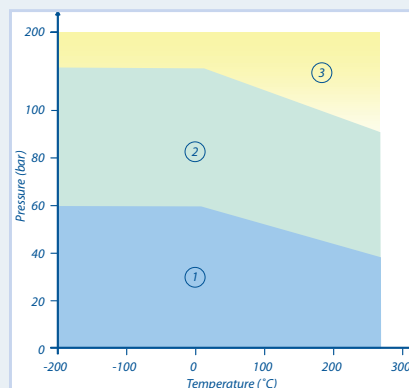

Pressure/Temperature Graph:

Area 1: Usually satisfactory to use without reference.
 Area 2: Usually satisfactory, but suggest you refer to Klinger for advice.
 Area 3: Caution: May be suitable but essential that you refer to Klinger for advice.

Sheet Material

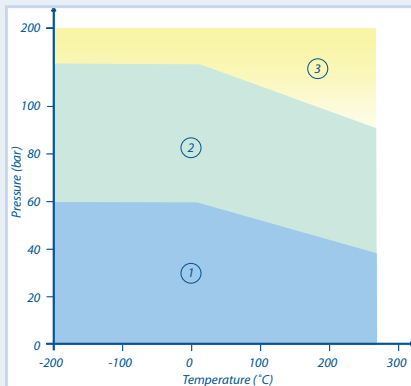

Pressure/Temperature Graph:

Area 1: Usually satisfactory to use without reference.
 Area 2: Usually satisfactory, but suggest you refer to Klinger for advice.
 Area 3: Caution: May be suitable but essential that you refer to Klinger for advice.

Economical, modified PTFE

Applications:

- Ideal for strongly alkaline environments
- Modified PTFE material with excellent chemical resistance and good mechanical properties. Suitable for a wide range of applications with the exception of strongly acidic conditions
- Ideal for aggressive chemicals, steam and oxygen applications.

Properties:

- Economical alternative to Top-Chem-2000
- Good mechanical properties at low to medium temperatures
- Very good chemical resistance
- Available in sheet form and as cut gaskets
- Anti-stick finish on both sides

Typical Specifications:

Colour :	Off-white
Compressibility (ASTM F36J) :	4%
Recovery (ASTM F36J) :	40%
Stress relaxation	
DIN 52913: 30MPa, 16h/150°C :	18 N/mm ²
Klinger hot/cold compression	
Decrease in thickness at 23°C, 50MPa	10%
Decrease in thickness at 250°C, 50MPa	40%
Gas leakage (DIN 3535/6) :	<0.1ml/min
Thickness increase after immersion in:	
H ₂ SO ₄ , 100%, 18h/230°C	Not Suitable
HNO ₃ , 100%, 18h/23°C	1%
NaOH, 33%, 72h/110°C	1%
Density :	3.0g/cm ³
(Based on 1.5mm thick sample)	

Tests and Certifications:

- BAM Approval for use with oxygen 130 bar / 200°C
- KTW Approval
- DIN DVGW
- FDA Conformity
- Germanischer Lloyd
- TA Luft Approval

Availability:

- Sheeting (m): 1.5 x 1.5
- Thickness (mm): 1.0, 1.5, 2.0, 3.0

PTFE

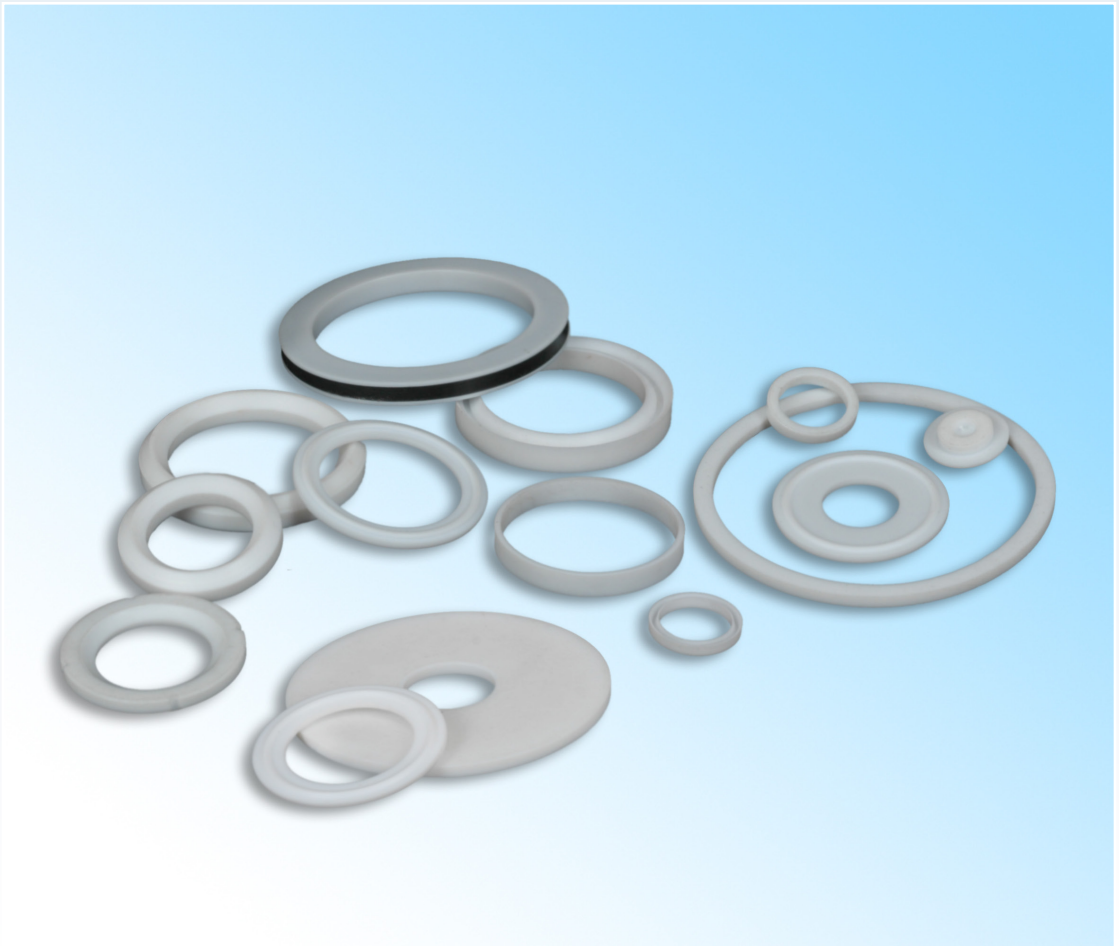



Polytetrafluoroethylene (PTFE) is almost chemically inert being attacked only under extreme conditions by molten alkali metals, certain fluorine compounds at elevated temperature and nuclear radiation. In this respect PTFE is very useful as a gasket material, but unfortunately, the material has a tendency to creep under load and has limited use in such applications.

Modified PTFE materials allow the benefits of PTFE to be utilised at higher compressive loads and higher temperatures. Expanding the PTFE, for example, produces a softer material with a higher strength than conventional PTFE. Whereas the addition of a filler such as silica, silicon carbide or barium sulphate lends the material better hot and cold flow resistance without negatively affecting the chemical resistance (see KLINGER-top-chem grades on pages 147 to 152).

PTFE can also be used as an envelope to a more conventional compressed fibre gasket material insert. This combines the chemical resistance of the PTFE with the stress retention and recovery properties of the insert and reduces the negative effect of the PTFE on the joint's mechanical stability.

General Properties of PTFE

- Outstanding chemical resistance
- Suitable for use with foodstuffs and pharmaceutical applications
- Insoluble in solvents, even at increased temperature
- Stable to light
- Does not absorb water
- Excellent electrical insulating capacity
- Low thermal conductivity

Applications

- Aggressive or toxic fluids
- Pharmaceutical industry
- Food industry
- Chemical industry

Expanded PTFE: KLINGERsoft-chem and KLINGERsealex

Soft-chem is a soft, highly compressible sealing material manufactured from expanded PTFE. Unlike conventional PTFE materials, Soft-chem has good creep resistance and bolt torque retention properties allowing it to be used to higher temperatures and to seal higher internal pressures.

KLINGERsealex is also manufactured in expanded PTFE but is in tape form with a pressure sensitive adhesive backing strip to assist with installation. Since the material is available in roll form it offers a solution to jointing needs without the need to maintain large stocks of cut gaskets.

Highly compressible, expanded PTFE

Applications:

- Virtually all media or where bolt load is limited
- Food and pharmaceutical applications
- Glass-lined or enamel flanges

Properties:

- Good mechanical properties at low to medium temperatures
- Excellent chemical resistance
- Highly compressible
- Available in sheet form and as cut gaskets

Typical Specifications:

Colour :	White
Compressibility (ASTM F36J) :	50-60%
Recovery (ASTM F36J) :	13-17%
Stress relaxation	
DIN 52913: 30MPa, 16h/150°C :	15 N/mm ²
Klinger hot/cold compression	
Decrease in thickness at 23°C, 25MPa	35%
Decrease in thickness at 150°C, 25MPa	30%
Gas leakage (DIN 3535/6) :	<0.01 ml/min
Density :	0.9g/cm ³
(Based on 1.5mm thick sample)	

Tests and Certifications:

- FDA Conformity

Availability:

- Sheeting (m): 1.5 x 1.5
- Thickness (mm): 1.0, 1.5, 2.0, 3.0

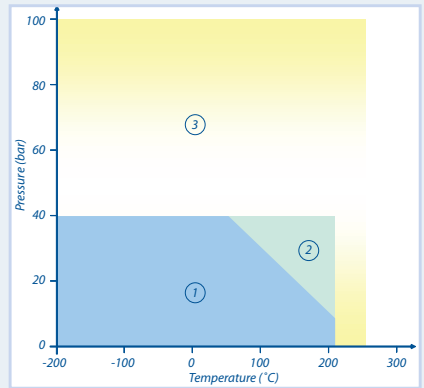
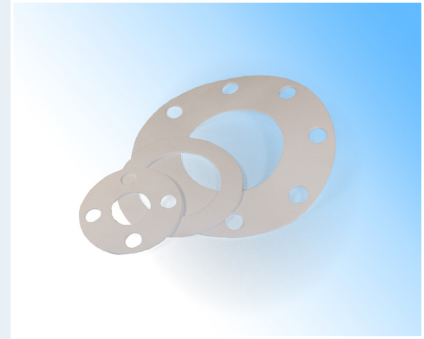

Pressure/Temperature Graph:

Area 1: Usually satisfactory to use without reference.

Area 2: Usually satisfactory, but suggest you refer to Klinger for advice.

Area 3: Caution: May be suitable but essential that you refer to Klinger for advice.

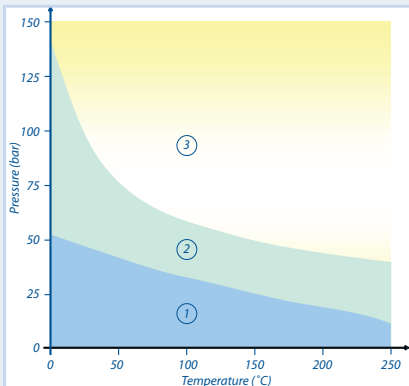

Pressure/Temperature Graph:

Area 1: Usually satisfactory to use without reference.

Area 2: Usually satisfactory, but suggest you refer to Klinger for advice.

Area 3: Caution: May be suitable but essential that you refer to Klinger for advice.

Expanded PTFE Tape with adhesive backing

Applications:

- Virtually all media or where bolt load is limited
- Food and pharmaceutical applications
- Glass-lined or enamel flanges

Properties:

- Soft, highly compressible PTFE gasket material on a roll, with excellent chemical resistance and good creep properties
- Good mechanical properties at low temperatures
- Excellent chemical resistance
- Highly compressible

Typical Specifications:

Colour :	White
Compressibility (ASTM F36L) :	75-85%
Creep relaxation	
ASTM F-38 (3000 psi) :	44%
Gas leakage	
(ASTM F37B, 30psi Nitrogen, 3000psi load) :	4.8ml/hour
Density :	0.6g/cm ³
(Based on 7 x 2.5mm thick sample)	

Tests and Certifications:

- FDA Conformity

Availability:

Dimensions (mm)	Roll length (m)	Dimensions (mm)	Roll length (m)
3 x 1.5	30	14 x 5.0	5
5 x 2.0	20	17 x 6.0	5
7 x 2.5	15	20 x 7.0	5
10 x 3.0	8	25 x 8.0	5

PTFE Envelope with compressed fibre insert**Applications:**

- Virtually all media or where bolt load is limited
- Food and pharmaceutical applications

Properties:

- Excellent chemical resistance
- PTFE envelope gaskets comprise a compressed synthetic fibre gasket material insert with a PTFE envelope. The PTFE envelope protects the gasket from chemical attack. The insert provides the strength and resilience needed for demanding sealing operation
- This gasket offers excellent chemical resistance under moderate conditions of temperature and pressure

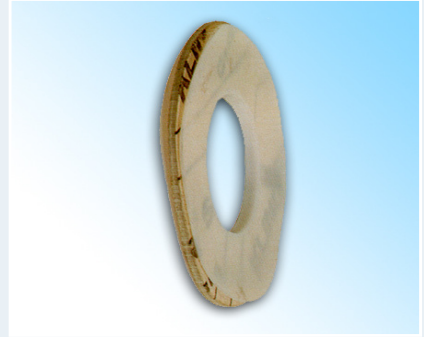

GORE™ Sealant Technologies



GORE™ SEALANTS - OUTSTANDING SEALING RELIABILITY



GORE™ Series 300 Tape



GORE™ GR



GORE™ DF Joint Sealant Tape

W. L. Gore & Associates are the world's leading supplier of expanded polytetrafluoroethylene (PTFE) components used in the transport and sealing of industrial fluids.

For over 25 years, GORE™ has been developing a complete understanding of factors that influence the effective sealing of vessels, pumps, valves and piping systems. This enable GORE™ to manufacture a wide range of sealing products renowned for quality and reliability.

At the heart of every product is a proprietary form of expanded PTFE. The unique properties of GORE™ expanded PTFE enable the engineering of high-performance products that are recognised throughout industry as the best on the market.

With this outstanding reputation in the sealing industry a partnership between Klinger and GORE™ was formed. Klinger are now an authorised distributor of GORE™ sealing products to compliment the Klinger's range of semi-metallic gaskets and KLINGERSIL range.

Sheet Material



Multi-directional ePTFE with diffusion tight layer

Applications:

- Designed for use in steel flanges, glass-lined steel flanges, FRP flanges and is also suitable for PTFE and rubber-lined flanges.
- Applications requiring excellent sealing properties at low surface stresses.
- For industrial use only

Properties:

- 100% expanded PTFE
- Seals at very low bolt load
- Chemically inert
- Temperature resistant
- Highly conformable
- Dimensionally stable
- Resists creep and cold flow
- For industrial use only

Typical Specifications:

Colour :	White
Compressibility (ASTM F36) :	57%
Temperature range :	-268°C to 270°C
Maximum temperature :	315°C for short periods
Maximum pressure :	40bar
Design factors	
ASME m factor :	2.4
ASME y :	1500psi

Tests and Certifications:

- TA-Luft Approval

Availability:

- Thickness (mm) : 1.5, 2.0, 3.0 & 6.0
- Cut gaskets to suit :
ASME class 150 & 300 from 1/2" to 24"
DIN rating from PN6 to PN40 at sizes from 15mm to 600mm

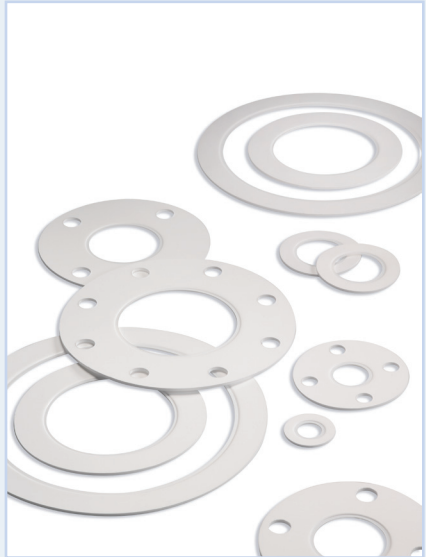
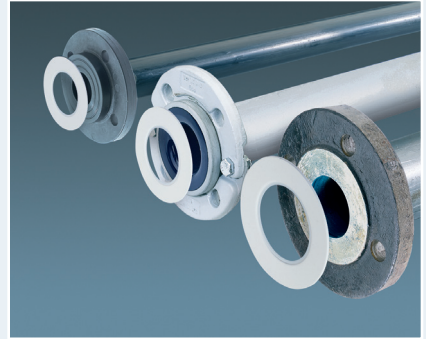

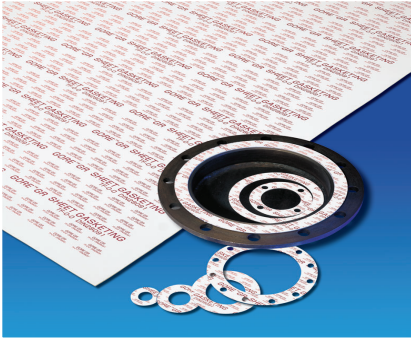

Multi-directional ePTFE

Applications:

- Designed for use in steel flanges, glass-lined steel flanges, FRP flanges and PTFE and rubber-lined flanges
- For industrial use only

Properties:

- Chemically inert
- Soft & conformable
- Dimensionally stable
- High tensile strength
- Resistant to creep & cold flow
- For industrial use only

Typical Specifications:

Colour :	White
Compressibility (ASTM F36) :	57%
Temperature range :	-268°C to 270°C
Maximum temperature :	315°C for short periods
Maximum pressure :	40bar

Tests and Certifications:

- TA-Luft Approval

Availability:

- Thickness (mm) :1.0, 1.5, 3.0 & 6.0
- Sheeting (m) : 1.5 x 1.5

Mono-directional ePTFE tape with adhesive backing

Applications:

- Designed for use in steel flanges, glass-lined steel flanges, FRP flanges and PTFE and rubber-lined flanges
- Large or complex flange shapes
- For industrial use only

Properties:

- 100% expanded PTFE
- Chemically inert, temperature-resistant
- Ideal for large, complex or damaged surfaces
- No wasteful scrap
- Low stress to seal
- Easy to install
- Extremely tight seal
- Outstanding versatility
- Reliable sealing performance
- For industrial use only

Typical Specifications:

Colour :	White
Temperature range :	-268°C to 270°C
Maximum temperature :	315°C for short periods
Maximum pressure :	10bar
Design factors	
ASME m factor :	1.5
ASME y :	2500psi

Tests and Certifications:

- TA-Luft Approval
- BAM Approval for use with oxygen
- DIN-DVGW

Availability:

Width (mm)	Thickness (mm)	Spool Length (m)			
		5	10	25	50
1.0	1.0	-	-	✓	✓
3.0	1.5	-	✓	✓	✓
5.0	2.0	-	✓	✓	✓
7.0	2.5	-	✓	✓	✓
10.0	3.0	-	✓	✓	✓
14.0	5.0	-	✓	✓	✓
17.0	6.0	✓	✓	✓	-
20.0	7.0	✓	✓	✓	-
25.0	9.0	✓	✓	-	-



Sheet Material

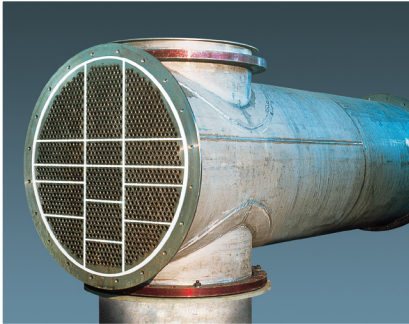

Sheet Material

Multi-directional ePTFE tape with adhesive backing

Applications:

- For use with steel pipe flanges and in large vessels requiring mechanically strong sealing materials
- Applications requiring good creep resistance
- For industrial use only

Properties:

- Made from 100% multi-directionally expanded PTFE
- Chemically inert
- Temperature resistant
- Highly conformable
- Dimensionally stable
- Resists creep & cold flow
- 1.5mm & 3.0mm thicknesses can be used to replace sheet gasketing
- Easy to install
- For industrial use only

Typical Specifications:

Thickness:	3.0mm	6.0mm
Colour:	White	White
Compressibility (ASTM F36) :	54%	44%
Recovery (ASTM F36) :	16%	27%
Temperature range :	-268°C to 270°C	
Maximum temperature:	315°C for short periods	
Design factors		
ASME m factor :	2.5	2.5
ASME y :	2,750 psi	3,330 psi

Availability:

Width (mm)	Thickness	
	3mm	6mm
10	✓	-
15	✓	✓
20	✓	✓
25	✓	✓
30	✓	✓

Available in 5, 10 and 20m spools

Multi-directional ePTFE tape with adhesive backing

Applications:

- Designed for use in glass-lined vessels
- For industrial use only

Properties:

- Made from 100% multi-directionally expanded PTFE
- Chemically inert
- Temperature resistant
- Highly conformable
- Dimensionally stable
- Resists creep & cold flow
- Easy to install
- For industrial use only

Typical Specifications:

Temperature range :	-268°C to 270°C
Maximum temperature :	315°C for short periods
Maximum pressure :	Full vacuum to 40 bar

Tests and Certifications:

- TA Luft Approval

Availability:

Width (mm)	Thickness		
	2mm	3mm	6mm
10	✓	✓	✓
15	✓	✓	✓
20	✓	✓	✓
25	✓	✓	✓
30	-	✓	✓
Available on 2.5 and 5m spools			
Available on 5, 10 and 15m spools			



Sheet Material

High Temperature





Introduction

High temperature sealing applications, such as those in waste gas and engine operations, require a gasket material that is capable of maintaining a long-term seal at temperatures often in excess of 500°C. At these temperatures, conventional gasket materials suffer from rapid thermal degradation which precludes their use as a component in gasket materials.

Klinger offer a range of high temperature gasket products capable of withstanding temperatures above 400°C and up to 1000°C. These materials exhibit low weight loss at high temperatures and provide high integrity seals at temperatures beyond the range of conventional gasket materials.

Klinger Thermica

Thermica is a high temperature compressed fibre material manufactured using the calendering process gasket material like Klingersil materials. The calendering process ensures the material is flexible, easy to cut and handle and has excellent leaktightness. The addition of mica lessens the ageing effects of elevated temperatures on the material's structure and increases its usable temperature range. Please see product details on page 169.

KLINGERMilam-PSS

KLINGERMilam-PSS is an asbestos free sealing material based on mica reinforced with a stainless steel tanged insert. It is specifically designed for hot, dry gas applications up to 900°C and 5 bar. However, the outstanding chemical resistance of mica makes the gasket suitable for a wide range of other applications. Please see product details on page 170.

Klinger Ferroflex SP/AF-II

Klinger SP/AF-II is an aramid fibre based gasket material with NBR binder with a tanged metallic insert to aid handling and blow-out properties. It has excellent oil and fuel resistance combined with good stress relaxation and high temperature resistance.

Typical applications include carburettor and diesel engines e.g. exhaust manifold, oil pan and heat shield. Please see product details on page 171.

Klinger Maxitherm

Klinger Maxitherm is a semi-metallic gasket product comprising a metallic core (Inconel 600 as standard) with a facing material specially developed for high temperature applications. It is designed as an alternative to asbestos based products for high temperature operations, offering a high integrity seal in applications which have traditionally precluded the use of most non-asbestos gasket products. Please see product details on page 65.

High Temperature Flexible Compressed Fibre

Introduction:

Klinger Thermica was developed to create an easy to use for higher temperature applications. Thermica has been engineered to have a very good loadbearing capacity and create a very leaktight seal which meets the most stringent industry standards. Thermica also possesses the strengths of a conventional compressed fibre material which makes it easy to cut and flexible.

Applications:

- Thermica is a compressed fibre material developed for high temperature service
- Thermica can be used as an alternative to graphite laminates for applications up to 400°C

Properties:

- Compressed fibre material which is easy to cut and handle
- Excellent leaktightness
- Excellent thermal stability up to 400°C
- Very good loadbearing capacity and stress relaxation properties

Typical Specifications:

Colour :	Beige
Max. temperature :	400°C
Compressibility (ASTM F36J) :	12%
Recovery (ASTM F36J) :	55%
Klinger hot/cold compression	
Decrease in thickness at 23°C, 50MPa	17%
Decrease in thickness at 300°C, 50MPa	13%
Decrease in thickness at 400°C, 50MPa	18%
Stress relaxation	
DIN 52913: 50MPa, 16h/300°C	28 N/mm ²
BS 7531: 40MPa, 16h/300°C (1.5mm):	27 N/mm ²
Thickness increase (ASTM F146), Oil IRM 903 : 5hr/150°C :	8%
Tightness (BS 7531) :	<1.0 ml/min

Availability:

- Thickness (mm): 0.8, 1.0, 1.5, 2.0 & 3.0
- Sheeting (m): 2.0 x 1.5





High Temperature Mica Laminate

Applications:

- Used for high temperature applications such as exhaust manifolds, turbines, turbochargers and burner ducting.

Properties:

- Asbestos-free gasket material with outstanding resistance to dry heat.
- Pure mica with tanged stainless steel reinforcing insert
- Good resistance to aggressive acids, bases, solvents, mineral oils
- Good compressive strength
- Non-flammable

Typical Specifications:

Colour :	Gold/Green
Compressibility (ASTM F36J) :	12-16%
Recovery (ASTM F36J) :	35-45%
Ignition loss (DIN 52911):	<5%
Maximum continuous service temperature:	900°C
Stress relaxation	
DIN 52913: 50MPa, 16h/300°C	33 N/mm ²
BS 7531: 40MPa, 16h/300°C :	28 N/mm ²

(Based on 1.3mm thick sample)

Tests and Certifications:

- Germanischer Lloyd

Availability:

- Thickness (mm): 1.3 & 3.0
- Sheeting (m): 1.2 x 1.0

Sheet Material

High Temperature Exhaust Gasket

Applications:

- Used in high temperature applications, such as exhaust manifolds and heat shields

Properties:

- Aramid fibre based material with pegged carbon steel core.
- Excellent oil and fuel resistance
- High temperature capability

Typical Specifications:

Colour :	Black both sides
Max. temperature :	900°C
Compressibility according to ASTM F36J :	16%
Minimum tensile strength (cross grain) :	>45N/mm ²
Stress relaxation according to DIN 52913 :	50 N/mm ²
Thickness increase, Oil 3 : 5hr/150°C :	<8%
Thickness increase, Fuel B : 5hr/20°C :	<7%
Thickness increase, Water-glycol :	<8%
Density :	2.3g/cm ³

Availability:

- Thickness (mm): 1.3
- Rolls (m): 0.5m wide



Paper, Cork & Rubber





Rubber, cork and paper-based gasket materials offer a low cost sealing solution for applications where the additional strength offered by composite materials with fibre reinforcements such as aramid, glass or carbon is not a requirement.

Paper, rubber and paper-based materials are often used in low temperature and low pressure applications.

Rubber materials

- Economical
- Easy to use
- A wide range of materials available to meet the requirements for many chemically aggressive applications.
- Seals at very low bolt loads
- Can be used with plastic and rubber lined pipework

Cork materials

A range of materials manufactured from the highest quality cork oak bonded with a synthetic rubber. These materials combine the natural compressibility of cork with the resilience of rubber, producing a material high mechanical strength and high compressibility.

Impregnated Paper

Applications:

- Extensively used in the automotive industry
- Low pressure applications with oil and fuel

Properties:

- Impregnated paper gasket providing reliable sealing at low cost
- Available in sheet form and as cut gaskets

Typical Specifications:

Colour :	Buff both sides
Compressibility (ASTM F36J) :	12-16%
Recovery (ASTM F36J) :	25-40%
Maximum continuous service temperature:	120°C
Maximum pressure:	8bar
Minimum tensile strength (ASTM F152):	>13N/mm ²
Thickness increase after immersion in:	
Oil IRM 903, 5h/150°C	<5%
Fuel B, 5h/23°C	<5%
Water, 5h/23°C	<30%
Weight increase after immersion in:	
Oil IRM 903, 5h/150°C	<15%
Fuel B, 5h/23°C	<15%
Water, 5h/23°C	<90%
Density:	0.7 g/cm ³
(Based on 0.8mm thick sample)	

Availability:

- Thickness (mm) : 0.15, 0.2, 0.25, 0.4, 0.5, 0.8, 1.0, 1.6, 3.2
- Sheeting (m) : 1.0 x 1.0
- Also available in rolls :

Thickness (mm)	0.15	0.2	0.25	0.4	0.5	0.8	1.0	1.6	3.2
Roll Length (m)	100	100	100	100	100	100	50	50	25



Sheet Material



Nitrile rubber bonded cork

Applications:

- Extensively used in the automotive industry
- Low pressure applications with oil and fuel

Properties:

- High-quality nitrile bonded cork
- Excellent resistance to oils, fuels, hydrocarbons and water
- Good sealing properties at low bolt loads
- Available in sheet form and as cut gaskets

Typical Specifications:

Compressibility (at 400psi) :	25-35%
Recovery :	80%
Hardness (Shore A) :	70-80
Maximum service temperature:	120°C
Minimum tensile strength (ASTM F152):	>1.7N/mm ²
Thickness increase after immersion in:	
ASTM Oil I	-5 to +10%
Oil IRM 903	0 to 15%
Fuel A	-2 to +10%
Density:	0.7-0.75 g/cm ³

Tests and Certifications:

- BS F66

Availability:

- Thickness (mm) : 1.0, 1.5, 2.0, 2.4, 3.0, 4.5, 6.0
- Sheeting (m) : 1.0 x 1.0

Sheet Material

Nitrile rubber bonded cork

Applications:

- Extensively used in the automotive industry
- Low pressure applications with oil and fuel

Properties:

- Medium-quality nitrile bonded cork
- Excellent resistance to oils, fuels, hydrocarbons and water
- Good sealing properties at low bolt loads
- Available in sheet form and as cut gaskets

Typical Specifications:

Compressibility (at 400psi) :	35-50%
Recovery :	80%
Hardness (Shore A) :	55-65
Maximum service temperature:	120°C
Minimum tensile strength (ASTM F152):	>1.0N/mm ²
Thickness increase after immersion in:	
ASTM Oil I	-5 to +5%
Oil IRM 903	15 to 50%
Fuel A	0 to +10%
Density:	0.55-0.6 g/cm ³

Availability:

- Thickness (mm) : 1.0, 1.5, 2.0, 2.4, 3.0, 4.5, 6.0
- Sheeting (m) : 1.0 x 1.0

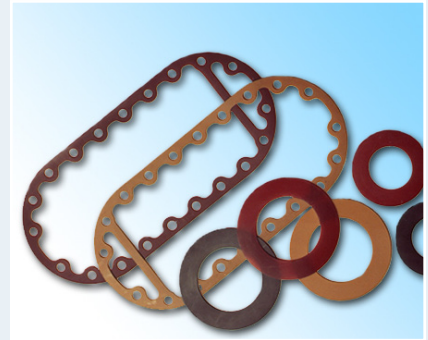



Neoprene® rubber bonded cork

Applications:

- Extensively used in the automotive industry
- Low pressure applications with oil and fuel

Properties:

- Medium-quality Neoprene® bonded cork
- Good resistance to oils, hydrocarbons and water
- Good sealing properties at low bolt loads
- Available in sheet form and as cut gaskets

Typical Specifications:

Compressibility (at 400psi) :	25-35%
Recovery :	80%
Hardness (Shore A) :	55-65
Maximum service temperature:	110°C
Minimum tensile strength (ASTM F152):	>1.1N/mm ²
Thickness increase after immersion in:	
ASTM Oil I	-2 to +10%
Oil IRM 903	0 to 30%
Fuel A,	0 to +10%
Density:	0.6-0.7 g/cm ³

Availability:

- Thickness (mm) : 1.0, 1.5, 2.0, 2.4, 3.0, 4.5, 6.0
- Sheeting (m) : 1.0 x 1.0

Sheet Material

SBR Rubber

Applications:

- Water, weak organic acids and moderate chemicals

Properties:

- The general purpose, synthetic equivalent to natural rubber, offering similar mechanical properties but better high temperature performance, flexibility and a greater resistance to attack from animal and vegetable oils

Typical Specifications:

Colour :	Black
Density :	1.5 g/cm ³
Hardness (Shore A) :	70°
Tensile strength :	4 N/mm ²
Elongation :	200%
Temperature range :	-10°C to +90°C

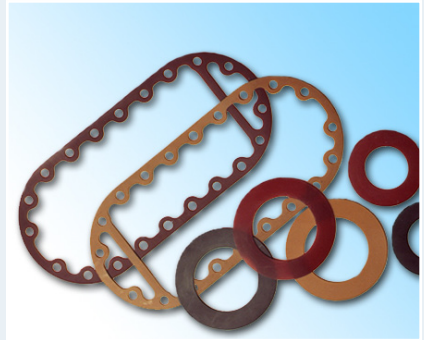

Neoprene® (CR) Rubber

Applications:

- Oils, fuels and moderate acids and alkalis
- Resistant to weathering and ozone

Properties:

- A good general purpose polychloroprene sheet
- Recommended for use in less demanding situations with air, water, non-oxidising acid and aliphatic hydrocarbons or where extra resistance to heat, ozone or weathering is required

Typical Specifications:

Colour :	Black
Density :	1.4 g/cm ³
Hardness (Shore A) :	65°
Tensile strength :	6 N/mm ²
Elongation :	300%
Temperature range :	-10°C to +90°C





Nitrile (NBR) Rubber

Applications:

- Oils and solvents, aromatic and aliphatic hydrocarbons and alcohols and animal fats

Properties:

- A universal, oil resistant rubber
- A good quality general purpose nitrile sheet
- Recommended where added resistance to mineral oils, alcohols and petroleum is required especially under hot conditions
- It is not recommended for use in sunlight, or near sparking electrical apparatus

Typical Specifications:

Colour :	Black
Density :	1.5 g/cm ³
Hardness (Shore A) :	65°
Tensile strength :	6 N/mm ²
Elongation :	250%
Temperature range :	-40°C to +100°C



EPDM Rubber

Applications:

- Acid, alkalis and hot water
- It is especially suited to hot water, strong alkali applications and potassium hydroxide

Properties:

- This material has good mechanical properties and is resistant to ageing, weathering, ozone, oxygen, steam and water
- Recommended for use where resistance to sunlight, weather, steam and ozone attack is important
- Suitable for use with phosphate ester-based hydraulic fluids and many mineral acids
- Not suitable for use with petroleum based oils or fluids
- WRAS approved grade is available

Typical Specifications:

Colour :	Black
Density :	1.3 g/cm ³
Hardness (Shore A) :	70°
Tensile strength :	3 N/mm ²
Elongation :	200%
Temperature range :	-40°C to +140°C

Hypalon® (CSM) Rubber

Applications:

- Acids, oils and non-aromatic benzenes

Properties:

- Excellent resistance to ozone and good resistance to mineral oils, weather and acids
- Possesses excellent resistance to ozone and good resistance to flame, mineral oil, heat, weather and acid, making it ideal for use outdoors or near sparking electrical equipment

Typical Specifications:

Colour :	Black
Density :	1.5 g/cm ³
Hardness (Shore A) :	70°
Tensile strength :	7 N/mm ²
Elongation :	200%
Temperature range :	-20°C to +120°C

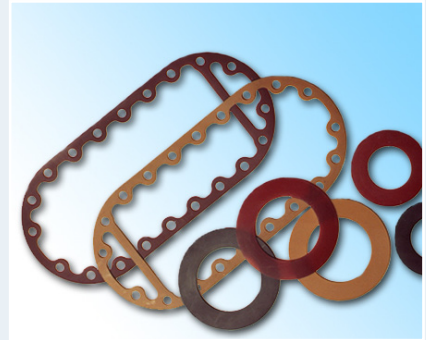

Viton® (FKM) Rubber

Applications:

- Many acids and alkalis, aliphatic hydrocarbons, oils and ozone

Properties:

- High temperature rubber material with resistance to a wide range of chemicals
- A high quality fluorocarbon rubber which exhibits a wide range of chemical resistance
- Extremely resistant to the effects of oxygen and ozone
- Retains excellent mechanical properties even when subjected to high temperatures for long periods of time

Typical Specifications:

Colour :	Black
Density :	2.0 g/cm ³
Hardness (Shore A) :	75°
Tensile strength :	10 N/mm ²
Elongation :	200%
Temperature range :	-20°C to +200°C





Butyl (IIR) Rubber

Applications:

- Requiring excellent gas tightness.
- Good general chemical stability including resistance to mineral acids

Properties:

- This material is resistant to phosphate ester based hydraulic fluids and mineral oils
- It is highly impermeable to gas and moisture but is not recommended for petroleum oils and fluids
- Good resistance to phosphate ester based hydraulic fluids and mineral oils
- It is highly impermeable to gas and moisture and has good general chemical resistance including mineral acids
- Resistance to petroleum oils and fuels is low

Typical Specifications:

Colour :	Black
Density :	1.2 g/cm ³
Hardness (Shore A) :	60°
Tensile strength :	13 N/mm ²
Elongation :	600%
Temperature range :	-40°C to +120°C



Natural (NR) Rubber

Applications:

- Oils, fuels and moderate acids and alkalis
- This rubber is weather and ozone resistant

Properties:

- A good general purpose polychloroprene sheet
- Recommended for use in less demanding situations with air, water, non-oxidising acid and aliphatic hydrocarbons or where extra resistance to heat, ozone or weathering is required
- A medium quality commercial grade which exhibits the qualities required for a good gasket
- Suitable for gaskets and packing where no particularly high resistance to heat, oils or solvents is required e.g. cold water, sewage pipes, etc.

Typical Specifications:

Colour :	Black
Density :	1.0 g/cm ³
Hardness (Shore A) :	40°
Tensile strength :	18 N/mm ²
Elongation :	600%
Temperature range :	-40°C to +80°C

Silicone (VMQ) Rubber

Applications:

- Vegetable fats and oils, water and where ozone resistance is required
- This material offers excellent high and low temperature properties and can be used in contact with foodstuffs

Properties:

- A high quality silicone rubber with excellent resistance to temperature extremes
- Good weathering properties and can be used in contact with foodstuffs and a white silicone rubber is also available

Typical Specifications:

Colour :	Translucent
Density :	1.2 g/cm ³
Hardness (Shore A) :	60°
Tensile strength :	7 N/mm ²
Elongation :	400%
Temperature range :	-60°C to +200°C (peak 250°C)

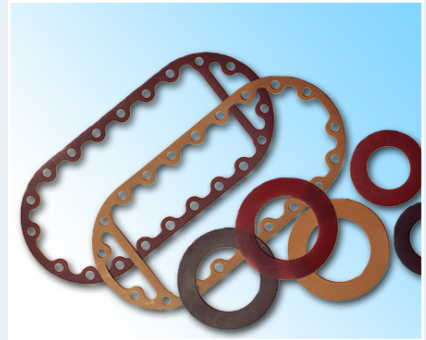

Polyurethane (PU) Rubber

Applications:

- Oils, benzene and ozone.
- An oil resistant rubber with excellent mechanical properties at low temperature.

Properties:

- Excellent resistance to oils, solvents, fats, grease, petrol, ozone, sunlight and weather
- The mechanical properties are low but care should be taken at high temperatures
- Polyurethanes are particularly susceptible to hydrolysis and should not be used with hot water or acid

Typical Specifications:

Colour :	Brown
Density :	1.26 g/cm ³
Hardness (Shore A) :	70° to 90°
Tensile strength :	25-30 N/mm ²
Elongation :	500-600%
Temperature range :	-40°C to +80°C (peak 130°C)



Insulation Sets





Insulation sets are used to limit corrosion in pipeline systems. Where dissimilar metals are present, the sets remove the possibility of the system acting as a galvanic cell and reduce the risk of galvanic corrosion of the pipework.

Insulation sets are also used to isolate cathodically protected piping systems where they prevent the flow of electrostatic charge.

Each flange insulation set comprises one central flat or oval section gasket, one insulation sleeve, two insulating and two plated steel back-up washers per bolt. The sets are individually packed and clearly labelled with the flange rating, size, type and material combination.

Properties of Standard Insulation Materials

	Neoprene® Faced Phenolic *	KLINGERSIL C-4430	Reinforced phenolic *	Phenolic	Mylar *	Glass rein- forced epoxy resin, G-10
Component	Gasket	Gasket	Insulating Washer	Insulating Sleeve	Insulating Sleeve	Gasket, washer, sleeve
Dielectric Strength (kV/mm)	19.7	59.5	7.9	5.5	157.5	29.5-31.5
Compressive Strength (N/mm²)	270	-	270	-	-	450
Flexural Strength (N/mm²)	155	-	155	-	-	450
Water Absorption (%)	1.6	10.6	1.0	1.0	0.8	0.05
Maximum Operating Temperature (°C)	107	400	107	107	145	150

* Denotes standard materials

Typical Example of Insulation Set Components

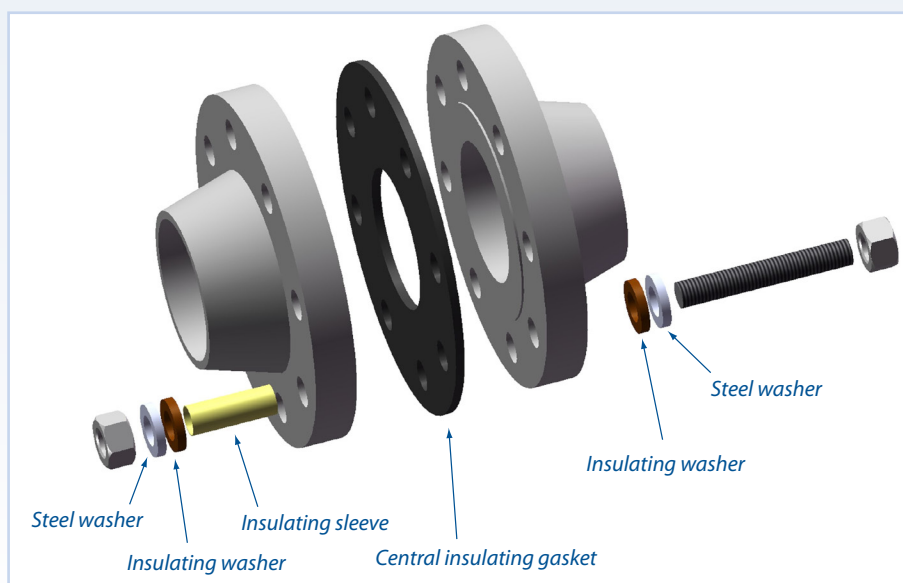

Klinger VCS & VCFS

Applications:

- Used to electrically isolate sections of pipework to restrict the likelihood of galvanic corrosion
- The VCS set can be used on high pressure applications including ASME Class 900 to 2500 and also up to API 15000 pipework
- VCFS also available for applications where a Fire-safe joint is required and can be used for ASME flanges up to Class 2500
- Can be used on mis-matched flanges, the sealing elements are positioned to allow the gasket to be used on RTJ and raised face applications

VCS Properties:

- VCS is manufactured from a machined metallic core with high-strength glass-fibre reinforced epoxy resin insulating faces
- Supplied with high-strength G10 insulating washers and sleeving to resist the forces present in high pressure applications and zinc-plated carbon steel washers to spread the load across the insulating washers during installation.
- Spring-energised PTFE or Viton® sealing elements are available
- Also available with high-temperature core manufactured from G-11 epoxy resin.

VCFS Properties:

- Fire-safe according to API 6FB
- Based on the VCS design and is manufactured with a stainless steel core with a glass-fibre reinforced epoxy resin facings with a spring energised PTFE seal
- The VCFS gasket features an additional Fire-safe, coated, E-ring
- VCFS can be used in both raised face and RTJ flanges
- Supplied with HCS washers in lieu of epoxy resin and zinc-plated steel washers. HCS washers are high strength and feature an electrically insulating coating

Typical Specifications:

Core material :	G-10	G-11
Compressive strength :	450MPa	340MPa
Dielectric strength :	29.5 to 31.5 kV/mm	19.7 kV/mm
Temperature range :	-200°C to +150°C	-200°C to +177°C
Sealing material :	Viton®	PTFE
Temperature range :	-15°C to +200°C	-200°C to +260°C

Availability:

- Also manufactured with Inconel and duplex stainless steel cores.



Klinger VCS

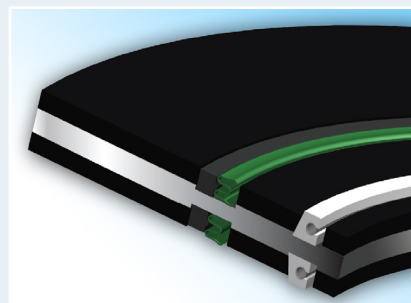

Klinger VCFS

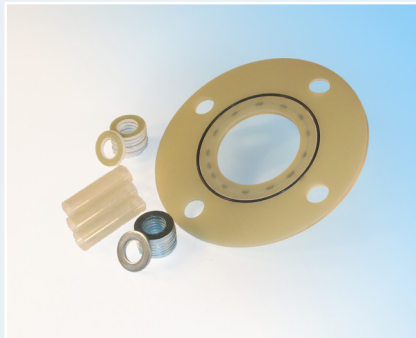

Klinger PGE

Applications:

- Used to electrically isolate sections of pipework to restrict the likelihood of galvanic corrosion
- Used on ASME Class 150, 300 & 600 pipework

Properties:

- Klinger PGE is manufactured from high-strength glass-fibre reinforced epoxy resin with sealing elements seated in machined grooves
- Supplied with high strength insulating washers and sleeving to resist the forces present in high pressure applications.
- A range of sealing elements are available such as Viton®, nitrile rubber and also spring-energised PTFE
- Excellent sealing characteristics at low bolt loads
- Also available with high-temperature core manufactured from G-11 epoxy resin.

Typical Specifications:

Core material :	G-10	G-11	
Compressive strength :	450MPa	340MPa	
Dielectric strength :	29.5 to 31.5 kV/mm	19.7 kV/mm	
Temperature range :	-200°C to +150°C	-200°C to +177°C	
Sealing material :	Viton®	PTFE	Nitrile
Temperature range :	-15°C to +200°C	-200°C to +260°C	-40°C to +120°C

Applications:

- Available in Type E full-face and Type F inside bolt circle styles

Sheet Material

Neoprene®-faced phenolic resin - Type E

Applications:

- Oil and hydrocarbons where flange insulation is a requirement
- Used on ASME Class 150 & 300 pipework and
- Low temperature, low pressure applications

Properties:

- This insulation set comprises a full-face Neoprene®-coated phenolic gasket with mylar insulating sleeves and reinforced phenolic and steel washers
- Manufactured from materials with high dielectric strength to ensure minimum electrical contact between flanges

Typical Specifications:

Core material :	Phenolic resin
Compressive strength :	450MPa
Dielectric strength :	19.7 kV/mm
Temperature range :	-200°C to +105°C
Sealing material :	Neoprene®
Temperature range :	-30°C to +110°C
Availability :	Other insulating materials are available, such as KLINGERSIL C-4430 for higher temperatures, KLINGERTop-chem-2000 for fire-safe applications and KLINGERTop-chem-2003 for chemically aggressive duties

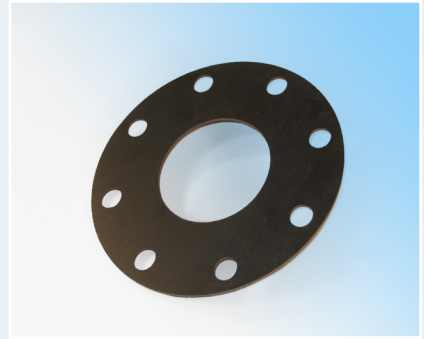

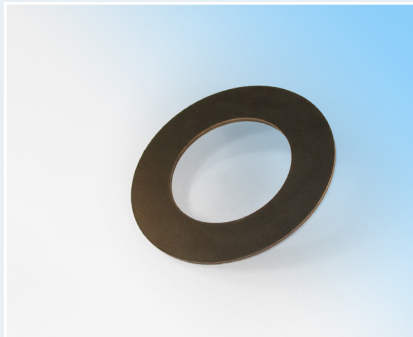

Neoprene®-faced phenolic resin - Type F

Applications:

- Oil and hydrocarbons where flange insulation is a requirement.
- Used on ASME Class 150 & 300 pipework
- Low temperature, low pressure applications

Properties:

- This insulation set comprises an I.B.C. (inside bolt circle) Neoprene®-coated phenolic gasket with mylar insulating sleeves and reinforced phenolic and steel washers.
- Manufactured from materials with high dielectric strength to ensure minimum electrical contact between flanges.

Typical Specifications:

Core material :	Phenolic resin
Compressive strength :	450MPa
Dielectric strength :	19.7 kV/mm
Temperature range :	-200°C to +105°C
Sealing material :	Neoprene®
Temperature range :	-30°C to +110°C
Availability :	Other insulating materials are available, such as KLINGERSIL C-4430 for higher temperatures, KLINGERtop-chem-2000 for fire-safe applications and KLINGERtop-chem-2003 for chemically aggressive duties

Sheet Material

**Dimensions of Type E Insulation Sets to suit ANSI Standard Flanges
ASME B16.21 Class 150**

Nominal Bore	Insulating Gasket				Insulating Washers	Insulating Sleeves	
	OD x ID	Diameter of Holes	Number of Bolt Holes	Bolt Circle Diameter	OD x ID (mm)	OD x ID (mm)	Length
1/2	89 x 16	16	4	60	29 x 16	15.0 x 13.1	32
3/4	98 x 22	16	4	70	29 x 16	15.0 x 13.1	35
1	108 x 25	16	4	79	29 x 16	15.0 x 13.1	34
1 1/4	117 x 32	16	4	89	29 x 16	15.0 x 13.1	37
1 1/2	127 x 38	16	4	98	29 x 16	15.0 x 13.1	40
2	152 x 51	19	4	121	33 x 19	17.6 x 16.1	43
2 1/2	178 x 64	19	4	140	33 x 19	17.6 x 16.1	50
3	191 x 76	19	4	152	33 x 19	17.6 x 16.1	53
4	229 x 102	19	8	191	33 x 19	17.6 x 16.1	53
5	254 x 127	22	8	216	38 x 22	21.7 x 20.5	53
6	279 x 152	22	8	241	38 x 22	21.7 x 20.5	56
8	343 x 203	22	8	298	38 x 22	21.7 x 20.5	62
10	406 x 254	25	12	362	44 x 25	23.5 x 22.5	65
12	483 x 305	25	12	432	44 x 25	23.5 x 22.5	68
14	533 x 337	29	12	476	51 x 29	27.5 x 26.0	75
16	597 x 387	29	16	540	51 x 29	27.5 x 26.0	78
18	635 x 438	32	16	578	56 x 32	30.0 x 28.5	84
20	699 x 489	32	20	635	56 x 32	30.0 x 28.5	94
24	813 x 591	35	20	749	60 x 35	33.5 x 32.1	100

ASME B16.21 Class 300

Nominal Bore	Insulating Gasket				Insulating Washers	Insulating Sleeves	
	OD x ID	Diameter of Holes	Number of Bolt Holes	Bolt Circle Diameter	OD x ID (mm)	OD x ID (mm)	Length
1/2	95 x 16	16	4	66	29 x 16	15.0 x 13.1	38
3/4	117 x 22	19	4	83	33 x 19	17.6 x 16.1	41
1	124 x 25	19	4	89	33 x 19	17.6 x 16.1	40
1 1/4	133 x 32	19	4	98	33 x 19	17.6 x 16.1	43
1 1/2	156 x 38	22	4	114	38 x 22	21.7 x 20.5	46
2	165 x 51	19	8	127	33 x 19	17.6 x 16.1	50
2 1/2	191 x 64	22	8	149	38 x 22	21.7 x 20.5	56
3	210 x 76	22	8	168	38 x 22	21.7 x 20.5	62
4	254 x 102	22	8	200	38 x 22	21.7 x 20.5	69
5	279 x 127	22	8	235	38 x 22	21.7 x 20.5	75
6	318 x 152	22	12	270	38 x 22	21.7 x 20.5	78
8	381 x 203	25	12	330	44 x 25	23.5 x 22.5	88
10	445 x 254	29	16	387	51 x 29	27.5 x 26.0	100
12	521 x 305	32	16	451	56 x 32	30.0 x 28.5	107
14	584 x 337	32	20	514	56 x 32	30.0 x 28.5	113
16	648 x 387	35	20	572	60 x 35	33.5 x 32.1	119
18	711 x 438	35	24	629	60 x 35	33.5 x 32.1	126
20	775 x 489	35	24	686	60 x 35	33.5 x 32.1	129
24	914 x 591	41	24	813	71 x 41	40.0 x 38.5	145

Dimensions of Type F Insulation Sets to suit ANSI Standard Flanges ASME B16.21 Class 150

Nominal Bore	Insulating Gasket	Number of Bolts	Insulating Washers	Insulating Sleeves	
	OD x ID (mm)		OD x ID (mm)	OD x ID (mm)	Length (mm)
1/2	43 x 16	4	29 x 16	15.0 x 13.1	32
3/4	52 x 22	4	29 x 16	15.0 x 13.1	35
1	62 x 25	4	29 x 16	15.0 x 13.1	34
1 1/4	71 x 32	4	29 x 16	15.0 x 13.1	37
1 1/2	81 x 38	4	29 x 16	15.0 x 13.1	40
2	100 x 51	4	33 x 19	17.6 x 16.1	43
2 1/2	119 x 64	4	33 x 19	17.6 x 16.1	50
3	132 x 76	4	33 x 19	17.6 x 16.1	53
4	170 x 102	8	33 x 19	17.6 x 16.1	53
5	192 x 127	8	38 x 22	21.7 x 20.5	53
6	217 x 152	8	38 x 22	21.7 x 20.5	56
8	275 x 203	8	38 x 22	21.7 x 20.5	62
10	335 x 254	12	44 x 25	23.5 x 22.5	65
12	405 x 305	12	44 x 25	23.5 x 22.5	68
14	446 x 337	12	51 x 29	27.5 x 26.0	75
16	510 x 387	16	51 x 29	27.5 x 26.0	78
18	545 x 438	16	56 x 32	30.0 x 28.5	84
20	602 x 489	20	56 x 32	30.0 x 28.5	94
24	713 x 591	20	60 x 35	33.5 x 32.1	100

ASME B16.21 Class 300

Nominal Bore	Insulating Gasket	Number of Bolt Holes	Insulating Washers	Insulating Sleeves	
	OD x ID (mm)		OD x ID (mm)	OD x ID (mm)	Length (mm)
1/2	49 x 16	4	29 x 16	15.0 x 13.1	38
3/4	62 x 22	4	33 x 19	17.6 x 16.1	41
1	68 x 25	4	33 x 19	17.6 x 16.1	40
1 1/4	78 x 32	4	33 x 19	17.6 x 16.1	43
1 1/2	90 x 38	4	38 x 22	21.7 x 20.5	46
2	106 x 51	8	33 x 19	17.6 x 16.1	50
2 1/2	125 x 64	8	38 x 22	21.7 x 20.5	56
3	144 x 76	8	38 x 22	21.7 x 20.5	62
4	176 x 102	8	38 x 22	21.7 x 20.5	69
5	211 x 127	8	38 x 22	21.7 x 20.5	75
6	246 x 152	12	38 x 22	21.7 x 20.5	78
8	303 x 203	12	44 x 25	23.5 x 22.5	88
10	357 x 254	16	51 x 29	27.5 x 26.0	100
12	418 x 305	16	56 x 32	30.0 x 28.5	107
14	481 x 337	20	56 x 32	30.0 x 28.5	113
16	535 x 387	20	60 x 35	33.5 x 32.1	119
18	592 x 438	24	60 x 35	33.5 x 32.1	126
20	649 x 489	24	60 x 35	33.5 x 32.1	129
24	770 x 591	24	71 x 41	40.0 x 38.5	145

Dimensions of Type E Insulation Sets to suit DIN Standard Flanges
PN10

Nominal Bore	Insulating Gasket				Insulating Washers	Insulating Sleeves	
	OD x ID (mm)	Diameter of Holes (mm)	Number of Bolt Holes	Bolt Circle Diameter (mm)		OD x ID (mm)	Length (mm)
15	95 x 17	14	4	65	29 x 16	13.2 x 12.2	41
20	105 x 22	14	4	75	29 x 16	13.2 x 12.2	45
25	115 x 28	14	4	85	29 x 16	13.2 x 12.2	45
32	140 x 37	18	4	100	33 x 19	17.2 x 16.2	45
40	150 x 43	18	4	110	33 x 19	17.2 x 16.2	45
50	165 x 55	18	4	125	33 x 19	17.2 x 16.2	49
65	185 x 70	18	8	145	33 x 19	17.2 x 16.2	49
80	200 x 83	18	8	160	33 x 19	17.2 x 16.2	53
100	220 x 107	18	8	180	33 x 19	17.2 x 16.2	53
125	250 x 131	18	8	210	33 x 19	17.2 x 16.2	57
150	285 x 159	22	8	240	38 x 22	21.2 x 20.2	57
200	340 x 208	22	8	295	38 x 22	21.2 x 20.2	61
250	395 x 260	22	12	350	38 x 22	21.2 x 20.2	65
300	445 x 310	22	12	400	38 x 22	21.2 x 20.2	65
350	505 x 341	22	16	460	38 x 22	21.2 x 20.2	65
400	565 x 392	26	16	515	51 x 29	25.2 x 24.2	65
450	615 x 443	26	20	565	51 x 29	25.2 x 24.2	69
500	670 x 494	26	20	620	51 x 29	25.2 x 24.2	69
600	780 x 596	30	20	725	56 x 32	28.2 x 27.2	69

PN16

Nominal Bore	Insulating Gasket				Insulating Washers	Insulating Sleeves	
	OD x ID (mm)	Diameter of Holes (mm)	Number of Bolt Holes	Bolt Circle Diameter (mm)		OD x ID (mm)	Length (mm)
15	95 x 17	14	4	65	29 x 16	13.2 x 12.2	41
20	105 x 22	14	4	75	29 x 16	13.2 x 12.2	45
25	115 x 28	14	4	85	29 x 16	13.2 x 12.2	45
32	140 x 37	18	4	100	33 x 19	17.2 x 16.2	45
40	150 x 43	18	4	110	33 x 19	17.2 x 16.2	45
50	165 x 55	18	4	125	33 x 19	17.2 x 16.2	49
65	185 x 70	18	8	145	33 x 19	17.2 x 16.2	49
80	200 x 83	18	8	160	33 x 19	17.2 x 16.2	53
100	220 x 107	18	8	180	33 x 19	17.2 x 16.2	53
125	250 x 131	18	8	210	33 x 19	17.2 x 16.2	57
150	285 x 159	22	8	240	38 x 22	21.2 x 20.2	57
200	340 x 208	22	12	295	38 x 22	21.2 x 20.2	61
250	405 x 260	26	12	355	51 x 29	25.2 x 24.2	65
300	460 x 310	26	12	410	51 x 29	25.2 x 24.2	69
350	520 x 340	26	16	470	51 x 29	25.2 x 24.2	73
400	580 x 390	30	16	525	56 x 32	28.2 x 27.2	77
450	640 x 441	30	20	585	56 x 32	28.2 x 27.2	81
500	715 x 492	33	20	650	60 x 35	31.2 x 30.2	81
600	840 x 592	36	20	770	67 x 38	34.2 x 33.2	85

Dimensions of Type E Insulation Sets to suit DIN Standard Flanges

PN25

Nominal Bore	Insulating Gasket				Insulating Washer	Insulating Sleeves	
	OD x ID	Diameter of Holes	Number of Bolt Holes	Bolt Circle Diameter (mm)	OD x ID (mm)	OD x ID (mm)	Length
15	95 x 17	14	4	65	29 x 16	13.2 x 12.2	45
20	105 x 22	14	4	75	29 x 16	13.2 x 12.2	49
25	115 x 28	14	4	85	29 x 16	13.2 x 12.2	49
32	140 x 37	18	4	100	33 x 19	17.2 x 16.2	49
40	150 x 43	18	4	110	33 x 19	17.2 x 16.2	49
50	165 x 55	18	4	125	33 x 19	17.2 x 16.2	53
65	185 x 70	18	8	145	33 x 19	17.2 x 16.2	57
80	200 x 83	18	8	160	33 x 19	17.2 x 16.2	61
100	235 x 107	22	8	190	38 x 22	21.2 x 20.2	61
125	270 x 131	26	8	220	51 x 29	25.2 x 24.2	65
150	300 x 159	26	8	250	51 x 29	25.2 x 24.2	69
200	360 x 207	26	12	310	51 x 29	25.2 x 24.2	73
250	425 x 259	30	12	370	56 x 32	28.2 x 27.2	77
300	485 x 308	30	16	430	56 x 32	28.2 x 27.2	81
350	555 x 340	33	16	490	60 x 35	31.2 x 30.2	89
400	620 x 389	36	16	550	67 x 38	34.2 x 33.2	93
450	670 x 439	36	20	600	67 x 38	34.2 x 33.2	97
500	730 x 488	36	20	660	67 x 38	34.2 x 33.2	101
600	845 x 588	39	20	770	71 x 41	37.2 x 36.2	105

PN40

Nominal Bore	Insulating Gasket				Insulating Washer	Insulating Sleeves	
	OD x ID	Diameter of Holes	Number of Bolt Holes	Bolt Circle Diameter (mm)	OD x ID (mm)	OD x ID (mm)	Length
15	95 x 17	14	4	65	29 x 16	13.2 x 12.2	45
20	105 x 22	14	4	75	29 x 16	13.2 x 12.2	49
25	115 x 28	14	4	85	29 x 16	13.2 x 12.2	49
32	140 x 37	18	4	100	33 x 19	17.2 x 16.2	49
40	150 x 43	18	4	110	33 x 19	17.2 x 16.2	49
50	165 x 55	18	4	125	33 x 19	17.2 x 16.2	53
65	185 x 70	18	8	145	33 x 19	17.2 x 16.2	57
80	200 x 83	18	8	160	33 x 19	17.2 x 16.2	61
100	235 x 107	22	8	190	38 x 22	21.2 x 20.2	61
125	270 x 131	26	8	220	51 x 29	25.2 x 24.2	65
150	300 x 159	26	8	250	51 x 29	25.2 x 24.2	69
200	375 x 207	30	12	320	56 x 32	28.2 x 27.2	81
250	450 x 259	33	12	385	60 x 35	31.2 x 30.2	89
300	515 x 308	33	16	450	60 x 35	31.2 x 30.2	97
350	580 x 338	36	16	510	67 x 38	34.2 x 33.2	105
400	660 x 384	39	16	585	71 x 41	37.2 x 36.2	103
450	685 x 432	39	20	610	71 x 41	37.2 x 36.2	113
500	755 x 480	42	20	670	71 x 41	40.2 x 39.2	117
600	890 x 578	48	20	795	83 x 48	46.2 x 45.2	133

Dimensions of Type F Insulation Sets to suit DIN Standard Flanges
PN10

Nominal Bore	Insulating Gasket	Number of Bolts	Insulating Washers	Insulating Sleeves	
	OD x ID (mm)		OD x ID (mm)	OD x ID (mm)	Length (mm)
15	50 x 17	4	29 x 16	13.2 x 12.2	41
20	60 x 22	4	29 x 16	13.2 x 12.2	45
25	70 x 28	4	29 x 16	13.2 x 12.2	45
32	80 x 37	4	33 x 19	17.2 x 16.2	45
40	90 x 43	4	33 x 19	17.2 x 16.2	45
50	105 x 55	4	33 x 19	17.2 x 16.2	49
65	125 x 70	8	33 x 19	17.2 x 16.2	49
80	140 x 83	8	33 x 19	17.2 x 16.2	53
100	160 x 107	8	33 x 19	17.2 x 16.2	53
125	190 x 131	8	33 x 19	17.2 x 16.2	57
150	216 x 159	8	38 x 22	21.2 x 20.2	57
200	271 x 208	8	38 x 22	21.2 x 20.2	61
250	326 x 260	12	38 x 22	21.2 x 20.2	65
300	376 x 310	12	38 x 22	21.2 x 20.2	65
350	436 x 341	16	38 x 22	21.2 x 20.2	65
400	487 x 392	16	51 x 29	25.2 x 24.2	65
450	537 x 443	20	51 x 29	25.2 x 24.2	69
500	592 x 494	20	51 x 29	25.2 x 24.2	69
600	693 x 596	20	56 x 32	28.2 x 27.2	69

PN16

Nominal Bore	Insulating Gasket	Number of Bolt Holes	Insulating Washer	Insulating Sleeves	
	OD x ID (mm)		OD x ID (mm)	OD x ID (mm)	Length (mm)
15	50 x 17	4	29 x 16	13.2 x 12.2	41
20	60 x 22	4	29 x 16	13.2 x 12.2	45
25	70 x 28	4	29 x 16	13.2 x 12.2	45
32	80 x 37	4	33 x 19	17.2 x 16.2	45
40	90 x 43	4	33 x 19	17.2 x 16.2	45
50	105 x 55	4	33 x 19	17.2 x 16.2	49
65	125 x 70	8	33 x 19	17.2 x 16.2	49
80	140 x 83	8	33 x 19	17.2 x 16.2	53
100	160 x 107	8	33 x 19	17.2 x 16.2	53
125	190 x 131	8	33 x 19	17.2 x 16.2	57
150	216 x 159	8	38 x 22	21.2 x 20.2	57
200	271 x 208	12	38 x 22	21.2 x 20.2	61
250	327 x 260	12	51 x 29	25.2 x 24.2	65
300	382 x 310	12	51 x 29	25.2 x 24.2	69
350	442 x 340	16	51 x 29	25.2 x 24.2	73
400	493 x 390	16	56 x 32	28.2 x 27.2	77
450	553 x 441	20	56 x 32	28.2 x 27.2	81
500	615 x 492	20	60 x 35	31.2 x 30.2	81
600	732 x 592	20	67 x 38	34.2 x 33.2	85

Dimensions of Type F Insulation Sets to suit DIN Standard Flanges

PN25

Nominal Bore	Insulating Gasket	Number of Bolts	Insulating Washers	Insulating Sleeves	
	OD x ID (mm)		OD x ID (mm)	OD x ID (mm)	Length (mm)
15	50 x 17	4	29 x 16	13.2 x 12.2	45
20	60 x 22	4	29 x 16	13.2 x 12.2	49
25	70 x 28	4	29 x 16	13.2 x 12.2	49
32	80 x 37	4	33 x 19	17.2 x 16.2	49
40	90 x 43	4	33 x 19	17.2 x 16.2	49
50	105 x 55	4	33 x 19	17.2 x 16.2	53
65	125 x 70	8	33 x 19	17.2 x 16.2	57
80	140 x 83	8	33 x 19	17.2 x 16.2	61
100	166 x 107	8	38 x 22	21.2 x 20.2	61
125	192 x 131	8	51 x 29	25.2 x 24.2	65
150	222 x 159	8	51 x 29	25.2 x 24.2	69
200	282 x 207	12	51 x 29	25.2 x 24.2	73
250	338 x 259	12	56 x 32	28.2 x 27.2	77
300	388 x 308	16	56 x 32	28.2 x 27.2	81
350	455 x 340	16	60 x 35	31.2 x 30.2	89
400	512 x 389	16	67 x 38	34.2 x 33.2	93
450	563 x 439	20	67 x 38	34.2 x 33.2	97
500	622 x 488	20	67 x 38	34.2 x 33.2	101
600	729 x 588	20	71 x 41	37.2 x 36.2	105

PN40

Nominal Bore	Insulating Gasket	Number of Bolt Holes	Insulating Washers	Insulating Sleeves	
	OD x ID (mm)		OD x ID (mm)	OD x ID (mm)	Length (mm)
15	50 x 17	4	29 x 16	13.2 x 12.2	45
20	60 x 22	4	29 x 16	13.2 x 12.2	49
25	70 x 28	4	29 x 16	13.2 x 12.2	49
32	80 x 37	4	33 x 19	17.2 x 16.2	49
40	90 x 43	4	33 x 19	17.2 x 16.2	49
50	105 x 55	4	33 x 19	17.2 x 16.2	53
65	125 x 70	8	33 x 19	17.2 x 16.2	57
80	140 x 83	8	33 x 19	17.2 x 16.2	61
100	166 x 107	8	38 x 22	21.2 x 20.2	61
125	192 x 131	8	51 x 29	25.2 x 24.2	65
150	222 x 159	8	51 x 29	25.2 x 24.2	69
200	288 x 207	12	56 x 32	28.2 x 27.2	81
250	350 x 259	12	60 x 35	31.2 x 30.2	89
300	415 x 308	16	60 x 35	31.2 x 30.2	97
350	472 x 338	16	67 x 38	34.2 x 33.2	105
400	544 x 384	16	71 x 41	37.2 x 36.2	103
450	570 x 432	20	71 x 41	37.2 x 36.2	113
500	626 x 480	20	71 x 41	40.2 x 39.2	117
600	745 x 578	20	83 x 48	46.2 x 45.2	133



PTFE Packing



Graphite & Carbon Packing



Synthetic Fibre Packings

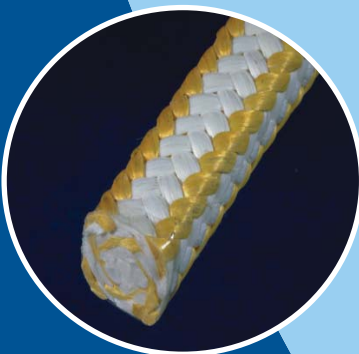

Hybrid Packings

Compression Packing

Packings

Packing Selection 200
 Chemical Resistance of Packings 202

PTFE Packing

Klinger TopLine K49 211
 Klinger TopLine K54S 212
 Klinger TopLine K54F 213
 Klinger TopLine K54H 214
 Klinger TopLine K55 215
 Klinger TopLine K4322 216

Graphite & Carbon Packing

Klinger TopLine K35 Rings 219
 Klinger TopLine K35 Tape 220
 Klinger TopLine K40 221
 Klinger TopLine K44 222
 Klinger TopLine K46 223
 Klinger TopLine K3222 224
 Klinger TopLine K3222W 225

Synthetic Fibre Packings

Klinger TopLine K10 229
 Klinger K11 230
 Klinger TopLine K25 231
 Klinger K4303 232
 Klinger K4310 233
 Klinger TopLine K4333 234

Hybrid Packings

Klinger TopLine K4311 237
 Klinger TopLine K4313 238



To aid the correct selection of the most appropriate TopLine grade and to ensure that a high integrity seal is achieved during application, Klinger recommend that the following fundamental questions are to be answered:

- Application type i.e. valve, rotary pump etc
- Media and concentration
- Maximum temperature
- Maximum pressure
- Shaft speed
- Special conditions i.e. fire-safe, WRAS, BAM approval
- Dimensions & details of stuffing box

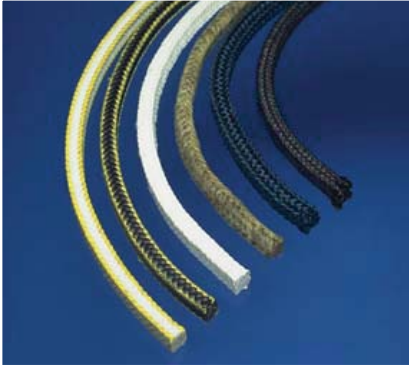

The success of a TopLine compression packing in sealing is a function of all of these factors and following these guidelines may generate a selection of suitable grades. Also of equal importance in effective and trouble-free sealing is proper attention to good installation and break-in procedures. Klinger recommend that our current fitting procedures be followed at all times.

Again as general guidelines, the following features are desirable to aid the choice of valve, rotary and reciprocating pump packings:

Valve Packings

Dense, flexible, temperature resistant, volumetrically stable, extrusion proof, low friction, non-corrosive

K10, K3222, K35, K4303, K4310, K4311, K4322, K44, K49, K54S, K54F, K55

Rotary Pump Packings

Resistant, long lasting, flexible, elastic & shaft-protecting

K10, K11, K25, K3222, K4322, K4330, K4333, K46, K44, K49, K54H, K55

Reciprocating Pump Packings

Abrasion proof, wear-resistant, volumetrically stable, extrusion proof, low-friction

K25, K4330, K55, K49, K4311, K4333, K4313,

Klinger TopLine - the optimised range of compression packings and graphite seals introduced to provide users with gland sealing products that meet today's demanding industrial services.

Environmental and financial constraints are placing a greater emphasis on tolerable sealing material leakage and emissions. However, as product throughput is maximised, process pressures, temperatures and speeds are often being increased.

Drawing upon more than 100 years packing experience coupled with modern production methodology and comprehensive test facilities, the Klinger TopLine range has been carefully structured to meet these current needs.



Klinger TopLine Range

- To provide a reliable and effective range of compression packings that have universal application throughout industry
- Utilising the most modern production techniques and materials
- To give the user predictable life expectancy
- Provide a complete range of packings to replace traditional products.
- To aid in the correct selection of the most appropriate packing for any given application
- To provide the user with the full technical support from full installation documentation through chemical compatibility and past application success
- To reduce inventory and stock holding costs

CHEMICAL RESISTANCE

Media	Synthetic Fibres							PTFE						Graphite					Hybrid			
	K10	K25	K4330	K4333	K11	K4303	K4310	K49	K545	K54F	K54H	K55	K4322	K35	K40	K44	K46	K3222	K3222W	K4311	K4313	
A																						
Acetaldehyde	A	A	A	A	A	A	A	A	A	A	A	A	A	A	A	A	A	A	A	A	A	A
Acetic acid	C	C	A	A	B	B	B	A	A	A	A	A	A	A	A	A	A	A	A	C	C	
Acetic acid (glacial)	C	C	A	A	B	B	B	A	A	A	A	A	A	A	A	A	A	A	A	C	C	
Acetic anhydride	C	C	A	A	B	B	B	A	A	A	A	A	A	A	A	A	A	A	A	C	C	
Acetone	A	A	A	A	B	A	A	A	A	A	A	A	A	A	A	A	A	A	A	A	A	
Acetylene	A	A	A	A	A	A	A	A	A	A	A	A	A	A	A	A	A	A	A	A	A	
Acrylic acid	A	A	A	A	C	A	A	A	A	A	A	A	A	A	A	A	A	A	A	A	A	
Acrylonitrile	A	A	A	A	A	A	A	A	A	A	A	A	A	A	A	A	A	A	A	A	A	
Adipic acid	C	A	A	A	B	A	A	A	A	A	A	A	A	A	A	A	A	A	A	A	A	
Air	A	A	A	A	A	A	A	A	A	A	A	A	A	A	A	A	A	A	A	A	A	
Alum	A	A	A	A	A	A	A	A	A	A	A	A	A	C	C	C	C	C	C	A	A	
Aluminium acetate	A	A	A	A	A	A	A	A	A	A	A	A	A	A	A	A	A	A	A	A	A	
Aluminium chloride	B	B	B	B	B	A	A	A	A	A	A	A	A	C	C	C	C	C	C	B	B	
Aluminium sulphate	A	A	A	A	C	A	A	A	A	A	A	A	A	A	A	A	A	A	A	A	A	
Ammonia	B	A	B	B	B	B	B	A	A	A	A	A	A	A	A	A	A	A	A	A	A	
Ammonium chloride	A	A	A	A	A	A	A	A	A	A	A	A	A	A	A	A	A	A	A	A	A	
Ammonium hydroxide	B	A	B	B	B	C	C	A	A	A	A	A	A	A	A	A	A	A	A	A	A	
Amyl acetate	A	A	A	A	A	A	A	A	A	A	A	A	A	A	A	A	A	A	A	A	A	
Amyl alcohol	A	A	A	A	A	A	A	A	A	A	A	A	A	A	A	A	A	A	A	A	A	
Anti-freezing agent	A	A	A	A	B	A	A	A	A	A	A	A	A	A	A	A	A	A	A	A	A	
Aniline	A	A	A	A	A	A	A	A	A	A	A	A	A	A	A	A	A	A	A	A	A	
Aqua-regia	B	B	C	C	C	A	C	C	A	A	A	C	C	B	B	B	B	B	B	B	B	
Argon	A	A	A	A	A	A	A	A	A	A	A	A	A	A	A	A	A	A	A	A	A	
Asphalt	A	A	A	A	A	A	A	A	A	A	A	A	A	A	A	A	A	A	A	A	A	
Aviation fuel	A	A	A	A	B	A	A	A	A	A	A	A	A	A	A	A	A	A	A	A	A	
B																						
Barium Chloride	A	A	A	A	A	A	A	A	A	A	A	A	A	A	A	A	A	A	A	A	A	
Benzene	A	A	A	A	B	A	A	A	A	A	A	A	A	A	A	A	A	A	A	A	A	
Benzaldehyde	A	A	A	A	B	A	A	A	A	A	A	A	A	A	A	A	A	A	A	A	A	
Benzoic acid	A	C	A	A	B	A	A	A	A	A	A	A	A	A	A	A	A	A	A	C	C	
Benzyl alcohol	A	A	A	A	B	A	A	A	A	A	A	A	A	A	A	A	A	A	A	A	A	
Benzoyl chloride	A	C	A	A	B	B	B	A	A	A	A	A	A	A	A	A	A	A	A	C	C	
Biphenyl	A	A	A	A	A	A	A	A	A	A	A	A	A	A	A	A	A	A	A	A	A	
Bitumen	A	A	A	A	A	A	A	A	A	A	A	A	A	A	A	A	A	A	A	A	A	
Blast furnace gas	A	A	A	A	B	A	A	A	A	A	A	A	A	A	A	A	A	A	A	A	A	
Bleaching liquor	A	A	A	A	A	C	C	A	A	A	A	A	A	A	A	A	A	A	A	A	A	
Boiler feed water	A	C	C	C	C	A	A	A	C	C	C	A	A	A	A	A	A	A	A	A	A	
Borax	A	A	A	A	A	A	A	A	A	A	A	A	A	A	A	A	A	A	A	A	A	
Brine	A	A	A	A	A	A	A	A	A	A	A	A	A	A	A	A	A	A	A	A	A	
Bromine	B	B	B	B	B	B	B	A	A	A	A	A	A	A	A	A	A	A	A	B	B	
Butadiene	A	A	A	A	B	A	A	A	A	A	A	A	A	A	A	A	A	A	A	A	A	
Butane	A	A	A	A	B	A	A	A	A	A	A	A	A	A	A	A	A	A	A	A	A	
Butanol	A	A	A	A	B	A	A	A	A	A	A	A	A	A	A	A	A	A	A	A	A	
Butyl acetates	A	A	A	A	B	A	A	A	A	A	A	A	A	A	A	A	A	A	A	A	A	
Butraldehyde	A	A	A	A	B	A	A	A	A	A	A	A	A	A	A	A	A	A	A	A	A	
Butyric acid	C	C	A	A	B	A	A	A	A	A	A	A	A	A	A	A	A	A	A	C	C	

Media	Synthetic Fibres							PTFE						Graphite					Hybrid			
	K10	K25	K4330	K4333	K11	K4303	K4310	K49	K54S	K54F	K54H	K55	K4322	K35	K40	K44	K46	K3222	K4311	K3222W	K4313	
C																						
Calcium acetate	A	A	A	A	A	A	A	A	A	A	A	A	A	A	A	A	A	A	A	A	A	A
Calcium bi-sulphite lye	A	A	A	A	A	A	A	A	A	A	A	A	A	A	A	A	A	A	A	A	A	A
Calcium chlorate	A	A	A	A	A	A	A	A	A	A	A	A	A	A	A	A	A	A	A	A	A	A
Calcium hydroxide	A	A	A	A	A	A	A	A	A	A	A	A	A	A	A	A	A	A	A	A	A	A
Calcium hypochlorite	C	C	A	A	B	B	B	A	A	A	A	A	C	C	C	C	C	C	C	C	C	C
Camphor	A	A	A	A	A	A	A	A	A	A	A	A	A	A	A	A	A	A	A	A	A	A
Camprolactam	A	A	A	A	A	A	A	A	A	A	A	A	A	A	A	A	A	A	A	A	A	A
Carbolic acid	A	A	A	A	A	A	A	A	A	A	A	A	A	A	A	A	A	A	A	A	A	A
Carbon dioxide	A	A	A	A	A	A	A	A	A	A	A	A	A	A	A	A	A	A	A	A	A	A
Carbon disulphide	A	A	A	A	B	A	A	A	A	A	A	A	A	A	A	A	A	A	A	A	A	A
Carbon monoxide	A	A	A	A	A	A	A	A	A	A	A	A	A	A	A	A	A	A	A	A	A	A
Carbon tetrachloride	A	A	A	A	B	A	A	A	A	A	A	A	A	A	A	A	A	A	A	A	A	A
Castor oil	A	A	A	A	A	A	A	A	A	A	A	A	A	A	A	A	A	A	A	A	A	A
Chlorine (dry)	B	B	B	B	B	A	A	A	A	A	A	A	A	A	A	A	A	A	A	A	B	B
Chlorine (wet)	B	B	B	B	B	B	B	C	A	A	A	C	C	C	C	C	C	C	C	C	B	B
Chlorine water	B	B	B	B	B	B	B	A	A	A	A	A	C	C	C	C	C	C	C	C	B	B
Chlorinated hydrocarbons	A	A	A	A	B	A	A	A	A	A	A	A	A	A	A	A	A	A	A	A	A	A
Chloroacetic acid	C	C	A	A	B	B	B	A	A	A	A	A	A	A	A	A	A	A	A	A	C	C
Chlorobenzene	A	A	A	A	B	A	A	A	A	A	A	A	A	A	A	A	A	A	A	A	A	A
Chloroform	A	A	A	A	B	A	A	A	A	A	A	A	A	A	A	A	A	A	A	A	A	A
Chlorosulphonic acid	C	C	A	A	B	A	A	A	A	A	A	A	A	A	A	A	A	A	A	A	C	C
Chromic acid	B	B	B	B	B	B	B	C	A	A	A	C	C	B	B	B	B	B	B	B	B	B
Citric acid	C	C	A	A	B	B	B	A	A	A	A	A	A	A	A	A	A	A	A	A	C	C
Coal gas	A	A	A	A	C	A	A	A	A	A	A	A	A	A	A	A	A	A	A	A	A	A
Coke oven gas	A	A	A	A	A	A	A	A	A	A	A	A	A	A	A	A	A	A	A	A	A	A
Copper acetate	A	A	A	A	A	A	A	A	A	A	A	A	A	A	A	A	A	A	A	A	A	A
Copper chloride	A	A	A	A	A	A	A	A	A	A	A	A	A	A	A	A	A	A	A	A	A	A
Copper sulphate	A	A	A	A	A	A	A	A	A	A	A	A	A	A	A	A	A	A	A	A	A	A
Creosote	A	A	A	A	B	A	A	A	A	A	A	A	A	A	A	A	A	A	A	A	A	A
Cresol	A	A	A	A	B	A	A	A	A	A	A	A	A	A	A	A	A	A	A	A	A	A
Crude oil	A	A	A	A	A	A	A	A	A	A	A	A	A	A	A	A	A	A	A	A	A	A
Cyclohexanol	A	A	A	A	B	A	A	A	A	A	A	A	A	A	A	A	A	A	A	A	A	A
D																						
Dibenzyl ether	A	A	A	A	A	B	A	A	A	A	A	A	A	A	A	A	A	A	A	A	A	A
Diesel Oil	A	A	A	A	A	A	A	A	A	A	A	A	A	A	A	A	A	A	A	A	A	A
Diethyl ether	A	A	A	A	B	A	A	A	A	A	A	A	A	A	A	A	A	A	A	A	A	A
Diphenyl oxide	A	A	A	A	B	A	A	A	A	A	A	A	A	A	A	A	A	A	A	A	A	A
Dye baths	A	A	A	A	A	A	A	A	A	A	A	A	A	A	A	A	A	A	A	A	A	A
E																						
Ethane	A	A	A	A	C	A	A	A	A	A	A	A	A	A	A	A	A	A	A	A	A	A
Ethanol	A	A	A	A	B	A	A	A	A	A	A	A	A	A	A	A	A	A	A	A	A	A
Ethanolamine	A	A	A	A	A	A	A	A	A	A	A	A	A	A	A	A	A	A	A	A	A	A
Ethyl acetate	A	A	A	A	B	A	A	A	A	A	A	A	A	A	A	A	A	A	A	A	A	A
Ethyl benzene	A	A	A	A	B	A	A	A	A	A	A	A	A	A	A	A	A	A	A	A	A	A

CHEMICAL RESISTANCE

Media	Synthetic Fibres							PTFE						Graphite					Hybrid			
	K10	K25	K4330	K4333	K11	K4303	K4310	K49	K545	K54F	K54H	K55	K4322	K35	K40	K44	K46	K3222	K4311	K3222W	K4313	
Ethylene	A	A	A	A	B	A	A	A	A	A	A	A	A	A	A	A	A	A	A	A	A	A
Ethylene glycol	A	A	A	A	B	A	A	A	A	A	A	A	A	A	A	A	A	A	A	A	A	A
Ethylene oxide	A	A	A	A	B	A	A	A	A	A	A	A	A	A	A	A	A	A	A	A	A	A
F																						
Fatty acids	A	A	A	A	A	A	A	A	A	A	A	A	A	A	A	A	A	A	A	A	A	A
Ferric chloride	A	A	A	A	C	A	A	A	A	A	A	A	A	A	A	A	A	A	A	A	A	A
Fixing bath	A	A	A	A	A	A	A	A	A	A	A	A	A	A	A	A	A	A	A	A	A	A
Fluorine	B	B	B	B	B	B	B	C	C	C	C	C	C	C	A	C	A	C	A	B	B	
Fluoro benzene	C	A	A	A	B	A	A	A	A	A	A	A	A	A	A	A	A	A	A	A	A	A
Fluosilicic acid	A	A	A	A	A	A	A	A	A	A	A	A	A	A	A	A	A	A	A	A	A	A
Formaldehyde	C	A	A	A	B	A	A	A	A	A	A	A	A	A	A	A	A	A	A	A	A	A
Formalin	A	A	A	A	A	A	A	A	A	A	A	A	A	A	A	A	A	A	A	A	A	A
Formic acid	C	C	A	A	B	B	B	A	A	A	A	A	A	A	A	A	A	A	A	C	C	
Freon 12	A	A	A	A	A	A	A	A	A	A	A	A	A	A	A	A	A	A	A	A	A	A
H																						
Heating oil	A	A	A	A	A	A	A	A	A	A	A	A	A	A	A	A	A	A	A	A	A	A
Hydraulic oil	A	A	A	A	B	A	A	A	A	A	A	A	A	A	A	A	A	A	A	A	A	A
Hydrazine hydrate	C	C	A	A	B	A	A	A	A	A	A	A	A	A	A	A	A	A	A	C	C	
Hydrobromic acid	C	C	A	A	B	B	B	A	A	A	A	A	A	A	A	A	A	A	A	C	C	
Hydrochloric acid	B	B	B	B	B	B	B	A	A	A	A	A	A	C	C	C	C	C	C	B	B	
Hydrofluoric acid	C	C	A	A	B	B	B	A	A	A	A	A	A	A	A	A	A	A	A	C	C	
Hydrofluorosilicic acid	C	C	A	A	B	B	B	A	A	A	A	A	A	C	C	C	C	C	C	C	C	
Hydrogen	A	A	A	A	A	A	A	A	A	A	A	A	A	A	A	A	A	A	A	A	A	A
Hydrogen chloride	B	B	B	B	B	B	B	A	A	A	A	A	A	C	C	C	C	C	C	B	B	
Hydrogen peroxide	A	B	B	B	B	A	A	A	A	A	A	A	A	A	A	A	A	A	A	B	B	
Hydrogen sulphide	A	A	A	A	B	A	A	A	A	A	A	A	A	A	A	A	A	A	A	A	A	A
I																						
Isopropyl acetate	A	A	A	A	A	A	A	A	A	A	A	A	A	A	A	A	A	A	A	A	A	A
Isopropyl alcohol	A	A	A	A	A	A	A	A	A	A	A	A	A	A	A	A	A	A	A	A	A	A
K																						
Kerosene	A	A	A	A	A	A	A	A	A	A	A	A	A	A	A	A	A	A	A	A	A	A
L																						
Lactic acid	A	A	A	A	A	A	A	A	A	A	A	A	A	A	A	A	A	A	A	A	A	A
Lead acetate	A	A	A	A	A	A	A	A	A	A	A	A	A	A	A	A	A	A	A	A	A	A
Lime	A	A	A	A	A	A	A	A	A	A	A	A	A	A	A	A	A	A	A	A	A	A
Lime water	A	A	A	A	A	A	A	A	A	A	A	A	A	A	A	A	A	A	A	A	A	A
Linseed oil	A	A	A	A	A	A	A	A	A	A	A	A	A	A	A	A	A	A	A	A	A	A
Lubricating oil	A	A	A	A	A	A	A	A	A	A	A	A	A	A	A	A	A	A	A	A	A	A
Lye	A	A	A	A	A	A	A	A	A	A	A	A	A	A	A	A	A	A	A	B	B	
M																						
Machine oil	A	A	A	A	A	A	A	A	A	A	A	A	A	A	A	A	A	A	A	A	A	A
Magnesium Chloride	A	A	A	A	A	A	A	A	A	A	A	A	A	A	A	A	A	A	A	A	A	A

Media	Synthetic Fibres							PTFE					Graphite				Hybrid					
	K10	K25	K4330	K4333	K11	K4303	K4310	K49	K54S	K54F	K54H	K55	K4322	K35	K40	K44	K46	K3222	K4311	K3222W	K4313	
Magnesium Sulphate	A	A	A	A	A	A	A	A	A	A	A	A	A	A	A	A	A	A	A	A	A	A
Maltic acid	C	A	A	A	C	B	B	A	A	A	A	A	A	A	A	A	A	A	A	A	A	A
Maleic anhydride	B	B	B	B	B	B	B	A	A	A	A	A	A	A	A	A	A	A	A	A	A	A
Mercury	A	A	A	A	A	A	A	A	A	A	A	A	A	A	A	A	A	A	A	A	A	A
Methacrylates	A	A	A	A	B	A	A	A	A	A	A	A	A	A	A	A	A	A	A	A	A	A
Methane	A	A	A	A	B	A	A	A	A	A	A	A	A	A	A	A	A	A	A	A	A	A
Methanol	A	A	A	A	A	A	A	A	A	A	A	A	A	A	A	A	A	A	A	A	A	A
Methyl alcohol	A	A	A	A	A	A	A	A	A	A	A	A	A	A	A	A	A	A	A	A	A	A
Methyl ester	A	A	A	A	A	A	A	A	A	A	A	A	A	A	A	A	A	A	A	A	A	A
Methyl glycol acetate	A	A	A	A	A	A	A	A	A	A	A	A	A	A	A	A	A	A	A	A	A	A
Methyl isobutyl ketone	A	A	A	A	A	A	A	A	A	A	A	A	A	A	A	A	A	A	A	A	A	A
Methylated spirits	A	A	A	A	A	A	A	A	A	A	A	A	A	A	A	A	A	A	A	A	A	A
Methylene Chloride	A	A	A	A	A	A	A	A	A	A	A	A	A	A	A	A	A	A	A	A	A	A
Molasses	A	A	A	A	A	A	A	A	A	A	A	A	A	A	A	A	A	A	A	A	A	A
Monochloroacetic acid	B	B	B	B	B	B	B	A	A	A	A	A	A	A	A	A	A	A	A	A	B	B
N																						
Naphtha	A	A	A	A	B	A	A	A	A	A	A	A	A	A	A	A	A	A	A	A	A	A
Natural gas	C	A	A	A	B	A	A	A	A	A	A	A	A	A	A	A	A	A	A	A	A	A
Nickel sulphate	A	A	A	A	A	A	A	A	A	A	A	A	A	A	A	A	A	A	A	A	A	A
Nitric acid	B	B	B	B	B	B	B	B	A	A	A	B	B	A	A	A	B	C	B	A	A	A
Nitrobenzene	C	A	A	A	B	A	A	A	A	A	A	A	A	A	A	A	A	A	A	A	A	A
O																						
Oleic acid	A	A	A	A	A	A	A	C	A	A	A	C	C	A	A	A	A	A	A	A	A	A
Oleum	A	A	A	A	A	A	A	A	A	A	A	B	B	A	A	A	A	C	C	A	A	A
Oxalic acid	A	A	A	A	A	A	A	A	A	A	A	A	A	A	A	A	A	A	A	A	A	A
Oxygen	A	A	A	A	A	A	A	B	A	A	A	B	B	B	B	B	B	A	B	A	A	A
P																						
Palmitic acid	A	A	A	A	A	A	A	A	A	A	A	A	A	A	A	A	A	A	A	A	A	A
Paper pulp	A	A	A	A	A	A	A	A	A	A	A	A	A	A	A	A	A	A	A	A	A	A
Paraffin	A	A	A	A	A	A	A	A	A	A	A	A	A	A	A	A	A	A	A	A	A	A
Peanut oil	A	A	A	A	A	A	A	A	A	A	A	A	A	A	A	A	A	A	A	A	A	A
Pentachlorophenol	A	B	B	B	A	C	C	A	A	A	A	A	A	A	C	A	C	A	C	B	B	B
Pentane	A	B	A	A	B	A	A	A	A	A	A	A	A	A	A	A	A	A	A	B	B	B
Petrol	A	A	A	A	B	A	A	A	A	A	A	A	A	A	A	A	A	A	A	A	A	A
Phenol	C	A	A	A	B	A	A	A	A	A	A	A	A	A	A	A	A	A	A	A	A	A
Phosgene	A	A	A	A	A	A	A	A	A	A	A	A	A	A	A	A	A	A	A	A	A	A
Phosphoric acid	C	C	A	A	B	B	B	A	A	A	A	A	A	A	A	A	A	A	A	C	C	C
Phosphorous	B	B	B	B	B	B	B	A	A	A	A	A	A	A	A	A	A	A	A	B	B	B
Pthalic acid	C	C	A	A	B	A	A	A	A	A	A	A	A	A	A	A	A	A	A	C	C	C
Pthalic anhydride	C	C	A	A	B	A	A	A	A	A	A	A	A	A	A	A	A	A	A	C	C	C
Potash Lye	C	B	B	B	B	B	B	A	A	A	A	A	A	A	A	A	A	A	A	B	B	B
Potassium acetate	A	A	A	A	A	A	A	A	A	A	A	A	A	A	A	A	A	A	A	A	A	A
Potassium bromide	A	A	A	A	A	A	A	A	A	A	A	A	A	A	A	A	A	A	A	A	A	A
Potassium carbonate	A	A	A	A	A	B	B	A	A	A	A	A	A	A	A	A	A	A	A	A	A	A
Potassium chlorate	A	A	A	A	A	A	A	A	A	A	A	A	A	A	A	A	A	A	A	A	A	A

Packings

CHEMICAL RESISTANCE

Media	Synthetic Fibres							PTFE						Graphite					Hybrid			
	K10	K25	K4330	K4333	K11	K4303	K4310	K49	K54S	K54F	K54H	K55	K4322	K35	K40	K44	K46	K3222	K4311	K3222W	K4313	
Potassium chloride	A	A	A	A	A	A	A	A	A	A	A	A	A	A	A	A	A	A	A	A	A	A
Potassium cyanide	A	A	A	A	A	A	A	A	A	A	A	A	A	A	A	A	A	A	A	A	A	A
Potassium hydroxide	B	B	B	B	B	B	B	A	A	A	A	A	A	A	A	A	A	A	A	A	B	B
Potassium nitrate	A	A	A	A	A	A	A	A	A	A	A	A	A	A	A	A	A	A	A	A	A	A
Potassium -permanganate	A	A	A	A	A	A	A	A	A	A	A	A	A	A	A	A	A	A	A	A	A	A
Potassium silicate	C	C	A	A	B	B	B	A	A	A	A	A	A	A	A	A	A	A	A	A	C	C
Propane	A	A	A	A	C	A	A	A	A	A	A	A	A	A	A	A	A	A	A	A	A	A
Propyl acetate	A	A	A	A	A	A	A	A	A	A	A	A	A	A	A	A	A	A	A	A	A	A
Propylene glycol	A	A	A	A	B	A	A	A	A	A	A	A	A	A	A	A	A	A	A	A	A	A
R																						
Rapeseed oil	A	A	A	A	A	A	A	A	A	A	A	A	A	A	A	A	A	A	A	A	A	A
Roast gas	B	B	B	B	B	B	B	A	A	A	A	A	A	A	A	A	A	A	A	A	B	B
S																						
Salicylic acid	A	A	A	A	C	A	A	A	A	A	A	A	A	A	A	A	A	A	A	A	A	A
Saturated steam	A	A	A	A	A	A	A	A	A	A	A	A	A	A	A	A	A	A	A	A	A	A
Sea water	A	A	A	A	A	A	A	A	A	A	A	A	A	A	A	A	A	A	A	A	A	A
Sewage	A	A	A	A	A	A	A	A	A	A	A	A	A	A	A	A	A	A	A	A	A	A
Silicone oil	A	A	A	A	A	A	A	A	A	A	A	A	A	A	A	A	A	A	A	A	A	A
Silver nitrate	A	A	A	A	A	A	A	A	A	A	A	A	A	A	A	A	A	A	A	A	A	A
Soap	A	A	A	A	A	A	A	A	A	A	A	A	A	A	A	A	A	A	A	A	A	A
Soda	A	A	A	A	A	B	B	A	A	A	A	A	A	A	A	A	A	A	A	A	A	A
Soda lye	A	B	B	B	A	B	B	A	A	A	A	A	A	A	A	A	A	A	A	A	B	B
Sodium acetate	A	A	A	A	A	A	A	A	A	A	A	A	A	A	A	A	A	A	A	A	A	A
Sodium bicarbonate	A	A	A	A	A	A	A	A	A	A	A	A	A	A	A	A	A	A	A	A	A	A
Sodium carbonate	A	A	A	A	C	B	B	A	A	A	A	A	A	A	A	A	A	A	A	A	A	A
Sodium chloride	A	A	A	A	A	A	A	A	A	A	A	A	A	A	A	A	A	A	A	A	A	A
Sodium cyanide	A	A	A	A	A	A	A	A	A	A	A	A	A	A	A	A	A	A	A	A	A	A
Sodium hydroxide	B	B	B	B	B	B	B	A	A	A	A	A	A	A	A	A	A	A	A	B	B	
Sodium hypochlorite	A	A	A	A	B	C	C	A	A	A	A	A	A	A	A	A	A	A	A	A	A	A
Sodium nitrate	A	A	A	A	A	A	A	A	A	A	A	A	A	A	A	A	A	A	A	A	C	C
Sodium silicate	A	A	A	A	A	A	A	A	A	A	A	A	A	A	A	A	A	A	A	A	C	C
Sodium sulphate	A	A	A	A	A	A	A	A	A	A	A	A	A	A	A	A	A	A	A	A	A	A
Sodium sulphide	A	A	A	A	A	A	A	A	A	A	A	A	A	A	A	A	A	A	A	A	A	A
Steam	A	C	A	A	A	C	C	A	A	A	A	A	A	A	A	A	A	A	A	A	C	C
Steam condensate	A	C	A	A	A	A	A	A	A	A	A	A	A	A	A	A	A	A	A	A	C	C
Stearic acid	A	A	A	A	C	A	A	A	A	A	A	A	A	A	A	A	A	A	A	A	A	A
Styrene	A	A	A	A	A	A	A	A	A	A	A	A	A	A	A	A	A	A	A	A	A	A
Sulphite lye	C	C	A	A	B	C	A	A	A	A	A	A	A	A	A	A	A	A	A	A	C	C
Sulphur dioxide	C	C	C	C	B	B	B	A	A	A	A	A	A	A	A	A	A	A	A	A	C	C
Sulphur trioxide	C	B	B	B	B	B	B	A	A	A	A	B	B	B	B	B	B	B	B	B	B	B
Sulphuric acid	C	B	B	B	B	B	B	A	A	A	A	B	B	B	B	B	B	B	B	B	B	B
Sulphurous acid	C	B	B	B	B	B	B	A	A	A	A	B	B	B	B	B	B	B	B	B	B	B
T																						
Tannic acid	A	A	A	A	C	A	A	A	A	A	A	A	A	A	A	A	A	A	A	A	A	A
Tar	A	A	A	A	A	A	A	A	A	A	A	A	A	A	A	A	A	A	A	A	A	A

Media	Synthetic Fibres							PTFE							Graphite				Hybrid			
	K10	K25	K4330	K4333	K11	K4303	K4310	K49	K54S	K54F	K54H	K55	K4322	K35	K40	K44	K46	K3222	K4311	K3222W	K4313	
Tetrahydrofuran	A	A	A	A	B	A	A	A	A	A	A	A	A	A	A	A	A	A	A	A	A	A
Tolulene	A	A	A	A	B	A	A	A	A	A	A	A	A	A	A	A	A	A	A	A	A	A
Town gas	A	A	A	A	A	A	A	A	A	A	A	A	A	A	A	A	A	A	A	A	B	B
Transformer oil	A	A	A	A	A	A	A	A	A	A	A	A	A	A	A	A	A	A	A	A	A	A
Tributyl phosphate	A	A	A	A	B	A	A	A	A	A	A	A	A	A	A	A	A	A	A	A	A	A
Triethanolamine	A	A	A	A	A	A	A	A	A	A	A	A	A	A	A	A	A	A	A	A	C	C
Turpentine	A	A	A	A	B	A	A	A	A	A	A	A	A	A	A	A	A	A	A	A	A	A
U																						
Urea	A	A	A	A	A	A	A	A	A	A	A	A	A	A	A	A	A	A	A	A	A	A
V																						
Vinegar	A	A	A	A	A	A	A	A	A	A	A	A	A	A	A	A	A	A	A	B	B	B
Vinyl acetate	A	A	A	A	B	A	A	A	A	A	A	A	A	A	A	A	A	A	A	A	A	A
Vinyl chloride	A	A	A	A	A	A	A	A	A	A	A	A	A	A	A	A	A	A	A	A	A	A
W																						
Washing soda	A	A	A	A	A	A	A	A	A	A	A	A	A	A	A	A	A	A	A	A	A	A
Water	A	A	A	A	A	A	A	A	A	A	A	A	A	A	A	A	A	A	A	A	A	A
Water, distilled	A	A	A	A	A	A	A	A	A	A	A	A	A	A	A	A	A	A	A	A	A	A
Whiskey	A	A	A	A	A	A	A	A	A	A	A	A	A	A	A	A	A	A	A	A	A	A
White spirt	A	A	A	A	A	A	A	A	A	A	A	A	A	A	A	A	A	A	A	A	A	A
Wine	A	A	A	A	A	A	A	A	A	A	A	A	A	A	A	A	A	A	A	A	A	A
X																						
Xylene	A	A	A	A	A	B	A	A	A	A	A	A	A	A	A	A	A	A	A	A	A	A
Z																						
Zinc chloride	A	A	A	A	B	A	A	A	A	A	A	A	A	A	A	A	A	A	A	A	A	A
Zinc oxide	A	A	A	A	A	A	A	A	A	A	A	A	A	A	A	A	A	A	A	A	A	A
Zinc sulphate	A	A	A	A	C	A	A	A	A	A	A	A	A	A	A	A	A	A	A	A	A	A

A - Suitable
 B - Suitability depends on operating conditions
 C - Not suitable

PTFE Packing



PTFE PACKINGS

Packings made from PTFE (Polytetrafluoroethylene) are a mainstay of the mechanical compression packing industry.

PTFE is well known for its outstanding resistance to chemical attack, low coefficient of friction and wide temperature tolerance including cryogenic service. This wide flexibility makes it a popular choice for those difficult applications where strong solvents, corrosive chemicals and oxidising media require to be sealed. Klinger have harnessed these properties in our range of PTFE based gland packings to give an enormously wide sealing capability in both valves and pumping applications.

General Properties:

- Exceptionally low-level of friction and adhesion
- Outstanding chemical resistance
- High compressive strength
- Good dimensional stability
- Continuous operation from -240 to 260 °C
- Readily conformable and easy to install

Packing Grades available:

- K54S
- K54H
- K54F
- K49
- K4322
- K55

GORE™ GFO® Packing

Applications:

- Virtually all media including strong acids and strong alkalis
- High-performance multi-service packing for both valves & pumping applications.

Properties:

- Klinger 49 packing is Klingerlock braided from GORE™ GFO®, PTFE filaments, which have been specially treated to incorporate a graphite based lubricant.
- Due to its wide service capabilities K49 TopLine packing offers the user a packing material with excellent sealing life and the option of reducing the variety of packings that must be held as stock.

Typical Specifications:

Min. temperature	-240°C
Max. steam temperature	280°C
Max. temperature	280°C
Max. static pressure	250 bar
Max. dynamic pressure	20 bar
Max. reciprocating pressure	200 bar
Max. speed	18m/s
pH range	0-14

The packing should not be subjected to the maximums of temperature, pressure and speed simultaneously.

Tests and Certifications:

- WRAS Approved for use with potable water

Availability:

Size (mm)	Length (m)	Size (mm)	Length (m)
3,2 x 3,2	8	12,5 x 12,5	8
5,0 x 5,0	8	14,0 x 14,0	8
6,5 x 6,5	8	16,0 x 16,0	8
8,0 x 8,0	8	19,0 x 19,0	8
9,5 x 9,5	8	22,0 x 22,0	8
11,0 x 11,0	8	25,0 x 25,0	8

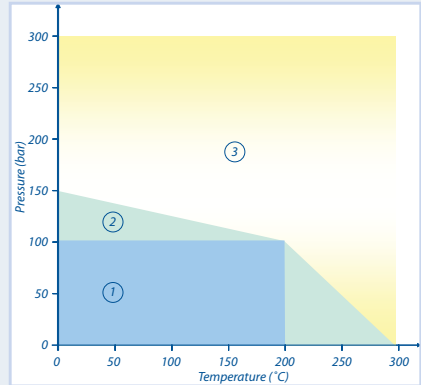

Pressure/Temperature Graph:

- Area 1: Usually satisfactory to use without reference.
- Area 2: Usually satisfactory, but suggest you refer to Klinger for advice.
- Area 3: Caution: May be suitable but essential that you refer to Klinger for advice.

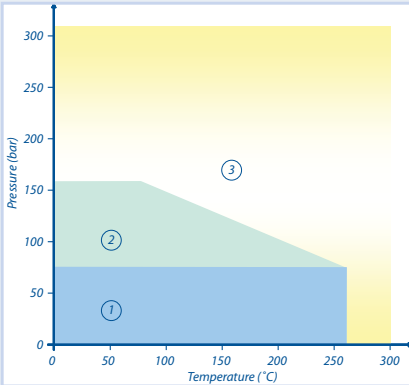

Pressure/Temperature Graph:

Area 1: Usually satisfactory to use without reference.
 Area 2: Usually satisfactory, but suggest you refer to Klinger for advice.
 Area 3: Caution: May be suitable but essential that you refer to Klinger for advice.

PTFE Filament Packing

Applications:

- Virtually all media including strong acids and strong alkalis
- An excellent choice for plant wide use on services, especially when a high level of resistance to chemical attack is required

Properties:

- This TopLine packing is manufactured from PTFE filaments added with PTFE lubricant.
- The special Klingerlock braiding process ensures a firm but flexible product of consistent density.
- Due to its diverse capabilities K54S offers the Engineer a packing that can cut maintenance requirements and also reduce stock holdings
- Most glands that are packed with K54S need little adjustment after the initial installation.

Typical Specifications:

Min. temperature	-240°C
Max. steam temperature	280°C
Max. temperature	280°C
Max. static pressure	200 bar
Max. speed	5m/s
pH range	0-14

The packing should not be subjected to the maximums of temperature, pressure and speed simultaneously.

Tests and Certifications:

- WRAS Approved for use with potable water

Availability:

Size (mm)	Length (m)	Size (mm)	Length (m)
3,2 x 3,2	8	12,5 x 12,5	8
5,0 x 5,0	8	14,0 x 14,0	8
6,5 x 6,5	8	16,0 x 16,0	8
8,0 x 8,0	8	19,0 x 19,0	8
9,5 x 9,5	8	22,0 x 22,0	8
11,0 x 11,0	8	25,0 x 25,0	8

Pure PTFE yarn packing for use with foods

Applications:

- Virtually all media including strong acids and strong alkalis

Properties:

- PTFE packing for valve applications requiring a pure, non-contaminating product with a high degree of resistance to chemical attack.
- Most glands that are packed with K54F need little adjustment after the initial installation.
- An excellent choice for plant wide use especially when a clean, non-contaminating packing is required with a high degree of chemical resistance.
- Water Research Council approval allows the packing to be used in potable water applications.

Typical Specifications:

Min. temperature	-200°C
Max. steam temperature	260°C
Max. temperature	260°C
Max. static pressure	200bar
pH range	0-14

The packing should not be subjected to the maximums of temperature, pressure and speed simultaneously.

Tests and Certifications:

- WRAS Approved for use with potable water
- FDA Conformity

Availability:

Size (mm)	Length (m)	Size (mm)	Length (m)
3,2 x 3,2	8	12,5 x 12,5	8
5,0 x 5,0	8	14,0 x 14,0	8
6,5 x 6,5	8	16,0 x 16,0	8
8,0 x 8,0	8	19,0 x 19,0	8
9,5 x 9,5	8	22,0 x 22,0	8
11,0 x 11,0	8	25,0 x 25,0	8

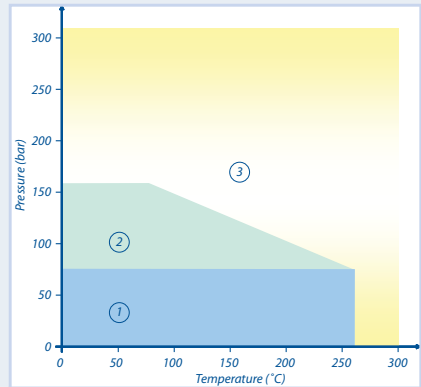

Pressure/Temperature Graph:

- Area 1: Usually satisfactory to use without reference.
- Area 2: Usually satisfactory, but suggest you refer to Klinger for advice.
- Area 3: Caution: May be suitable but essential that you refer to Klinger for advice.

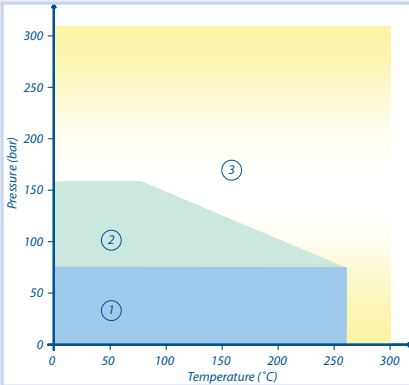
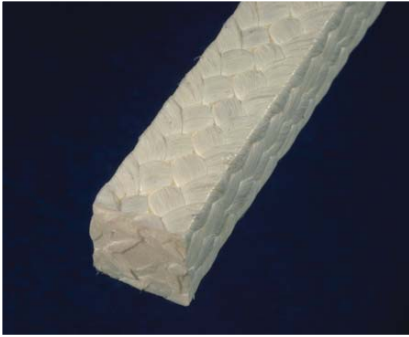

Pressure/Temperature Graph:

- Area 1: Usually satisfactory to use without reference.
- Area 2: Usually satisfactory, but suggest you refer to Klinger for advice.
- Area 3: Caution: May be suitable but essential that you refer to Klinger for advice.

PTFE yarn with oil lubricant

Applications:

- Virtually all media including strong acids and strong alkalis
- PTFE packing for pumping applications requiring a pure, non-contaminating product with a high degree of resistance to chemical attack.

Properties:

- Klinger K54H is manufactured from PTFE filaments to which we incorporate a mineral based lubricant that provides improved performance within dynamic applications.
- An excellent choice for plant wide use especially when a clean, non-contaminating packing is required with a high degree of chemical resistance

Typical Specifications:

Min. temperature	-240°C
Max. steam temperature	260°C
Max. temperature	260°C
Max. dynamic pressure	10bar
Max. reciprocating pressure	2bar
Max. speed	10m/s
pH range	0-14

The packing should not be subjected to the maximums of temperature, pressure and speed simultaneously.

Availability:

Size (mm)	Length (m)	Size (mm)	Length (m)
3,2 x 3,2	8	12,5 x 12,5	8
5,0 x 5,0	8	14,0 x 14,0	8
6,5 x 6,5	8	16,0 x 16,0	8
8,0 x 8,0	8	19,0 x 19,0	8
9,5 x 9,5	8	22,0 x 22,0	8
11,0 x 11,0	8	25,0 x 25,0	8

Graphite encapsulated PTFE yarn packing

Applications:

- Virtually all media including strong acids and strong alkalis
- New generation, multiservice packing for both valves & pumping applications.

Properties:

- Klingerlock braided offering excellent sealing & reliability in high performance duties
- Klinger K55 compression packing is manufactured from PTFE filaments, which have been specially treated to incorporate a high quality graphite based lubricant.

Typical Specifications:

Min. temperature	-200°C
Max. steam temperature	280°C
Max. temperature	280°C
Max. static pressure	250 bar
Max. dynamic pressure	25 bar
Max. reciprocating pressure	250 bar
Max. speed	20m/s
pH range	0-14

The packing should not be subjected to the maximums of temperature, pressure and speed simultaneously.

Tests and Certifications:

- WRAS Approved for use with potable water

Availability:

Size (mm)	Length (m)	Size (mm)	Length (m)
3,2 x 3,2	8	12,5 x 12,5	8
5,0 x 5,0	8	14,0 x 14,0	8
6,5 x 6,5	8	16,0 x 16,0	8
8,0 x 8,0	8	19,0 x 19,0	8
9,5 x 9,5	8	22,0 x 22,0	8
11,0 x 11,0	8	25,0 x 25,0	8

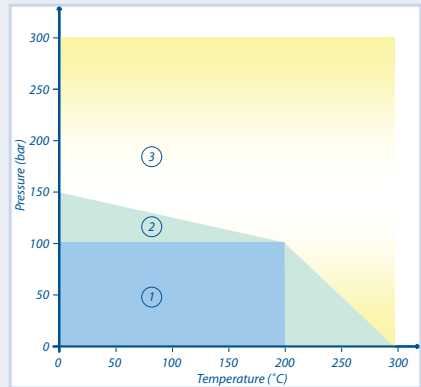

Pressure/Temperature Graph:

- Area 1: Usually satisfactory to use without reference.
- Area 2: Usually satisfactory, but suggest you refer to Klinger for advice.
- Area 3: Caution: May be suitable but essential that you refer to Klinger for advice.

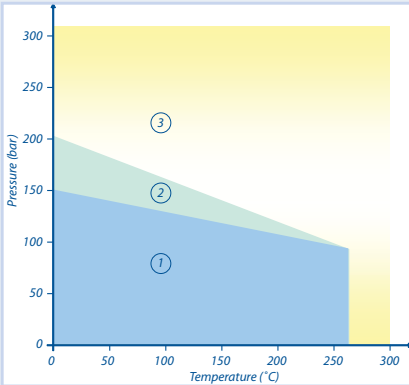

Pressure/Temperature Graph:

- Area 1: Usually satisfactory to use without reference.
- Area 2: Usually satisfactory, but suggest you refer to Klinger for advice.
- Area 3: Caution: May be suitable but essential that you refer to Klinger for advice.

PTFE yarn packing with graphite lubricant

Applications:

- Virtually all media including strong acids and strong alkalis
- A packing based on graphite enhanced PTFE allowing effective, long lasting performance in both valves and high speed pumps.

Properties:

- Klinger 4322 packing is manufactured from PTFE filaments, which have been pre-treated with a graphite based lubricant.
- Klingerlock braided

Typical Specifications:

Min. temperature	-240°C
Max. steam temperature	280°C
Max. temperature	280°C
Max. static pressure	300 bar
Max. dynamic pressure	25 bar
Max. speed	22m/s
pH range	0-14

The packing should not be subjected to the maximums of temperature, pressure and speed simultaneously.

Availability:

Size (mm)	Length (m)	Size (mm)	Length (m)
3,2 x 3,2	8	12,5 x 12,5	8
5,0 x 5,0	8	14,0 x 14,0	8
6,5 x 6,5	8	16,0 x 16,0	8
8,0 x 8,0	8	19,0 x 19,0	8
9,5 x 9,5	8	22,0 x 22,0	8
11,0 x 11,0	8	25,0 x 25,0	8

Graphite & Carbon Packing



CARBON & GRAPHITE PACKINGS

Often the terms carbon and graphite are used interchangeably, but in fact there is a recognisable difference in their crystalline structure. These differences permit selective use in many severe applications. Packings produced from these materials are intended to offer high temperature capability, good chemical resistance and markedly reduced spindle wear. By selecting or combining the many versions of carbon available, usually based on processed flake or filament form, we are able to offer a versatile range of packing with varied handling and performance characteristics.

These include high conformability, resistance to extrusion, chemical purity, temperature and oxidation resistance amongst others. Carefully designed packing sets based on carbon materials have helped reduce fugitive emissions whilst offering long service life and minimal maintenance.

General Properties

- Inert to most chemical media
- Thermally stable and has high thermal conductivity
- Permanent resilience
- Low co-efficient of friction
- Low modulus of elasticity
- Volumetrically stable
- Non-hardening - will not become brittle after controlled compression

Packings Available

- K3222
- K3222W
- K35 (Tape & Die-formed rings)
- K44
- K40
- K46

Die-formed packing rings and pressure seals

Applications:

- Virtually all media with the exception of powerful oxidising media
- Klinger K35 rings offer a leak-free sealing solution for high performance valve application which require excellent temperature and pressure characteristics

Properties:

- K35 rings have outstanding chemical resistance and are unaffected by the majority of chemical media employed within industry.
- K35 die-formed rings are a result of industry's requirement to find durable products able to offer improved sealing throughout a range of applications.
- The manufacturing process ensures a product that is volumetrically stable - without fillers or binders. K35 rings are also essentially impermeable and without porosity.
- Klinger manufacture virtually any size, section or density of die-formed ring depending upon requirement.
- Information required:
 - i) OD, ID and ring height
 - ii) Section and profile
 - iii) Endless, halved or split rings
 - iv) Density
 - v) Depth of stuffing box

Typical Specifications:

Min. temperature	-240°C
Max. steam temperature	650°C
Max. temperature	430°C
Max. static pressure	350 bar
Max. dynamic pressure	20 bar
Max. speed	5m/s
pH range	0-14

The packing should not be subjected to the maximums of temperature, pressure and speed simultaneously.

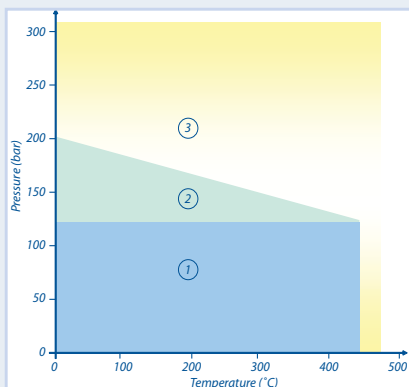

Pressure/Temperature Graph:

Area 1: Usually satisfactory to use without reference.

Area 2: Usually satisfactory, but suggest you refer to Klinger for advice.

Area 3: Caution: May be suitable but essential that you refer to Klinger for advice.



Exfoliated graphite tape

Applications:

- Virtually all media with the exception of powerful oxidisers
- Can be fitted directly into valve stuffing box and compressed to create a packing suitable for high temperature and high pressure applications
- Can also be supplied with a self-adhesive backing which can also be used as a gasket material.

Properties:

- Pure exfoliated graphite. The excellent conformability of graphite means that the material is suitable for applications where bolt load is limited or flanges are damaged
- Available as tape with or without adhesive backing
- Excellent resistance to steam
- Resistant to virtually all media
- Outstanding resistance to high and low temperature
- High compressibility
- Good leakage properties
- Unlimited storage life
- Easy to cut

Typical Specifications:

Min. temperature	-200°C
Max. steam temperature	650°C
Max. temperature	500°C
pH range	0-14

The packing should not be subjected to the maximums of temperature, pressure and speed simultaneously.

Tests and Certifications:

- WRAS Approved for use with potable water

Availability:

Tape width (mm)	Thickness (mm)	Roll length (m)
6.0	0.5	10
9.5	0.5	10
13.0	0.5	10
16.0	0.5	10
19.0	0.5	10
25.0	0.5	10
32.0	0.5	10
38.0	0.5	10
44.0	0.5	10
50.0	0.5	10

Carbon fibre yarn and Inconel® wire reinforcement

Applications:

- An exceptional packing combining carbon and Inconel® to produce a product for sealing valve glands in high pressure and high temperature applications.
- High pressure steam also the majority of acids, alkalis, solvents and greases.
- Header and footer rings for graphite ribbon packings like K3222 and K3222W

Properties:

- The additional graphite lubricant improves the sealing effect of Klinger K40, producing a dense non-porous matrix. It also improves the frictional properties of the packing, to allow easy operation of any valve stem once installed
- K40 has excellent chemical resistance and is unaffected by the majority of acids, alkalis, solvents and greases. (For further information on chemical compatibility please contact Klinger)

Typical Specifications:

Min. temperature	-100°C
Max. steam temperature	650°C
Max. temperature	430°C
Max. static pressure	200 bar
Max. speed	5m/s
pH range	0-14

The packing should not be subjected to the maximums of temperature, pressure and speed simultaneously.

Availability:

Size (mm)	Length (m)	Size (mm)	Length (m)
3,2 x 3,2	8	12,5 x 12,5	8
5,0 x 5,0	8	14,0 x 14,0	8
6,5 x 6,5	8	16,0 x 16,0	8
8,0 x 8,0	8	19,0 x 19,0	8
9,5 x 9,5	8	22,0 x 22,0	8
11,0 x 11,0	8	25,0 x 25,0	8

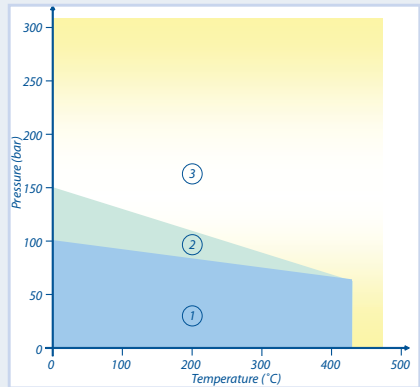

Pressure/Temperature Graph:

Area 1: Usually satisfactory to use without reference.
 Area 2: Usually satisfactory, but suggest you refer to Klinger for advice.
 Area 3: Caution: May be suitable but essential that you refer to Klinger for advice.

Packings

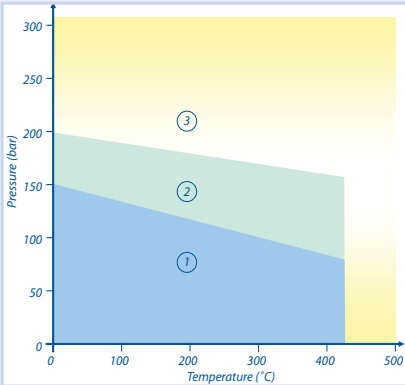

Pressure/Temperature Graph:

- Area 1: Usually satisfactory to use without reference.
- Area 2: Usually satisfactory, but suggest you refer to Klinger for advice.
- Area 3: Caution: May be suitable but essential that you refer to Klinger for advice.

Graphite yarn with blended graphite and PTFE lubricant

Applications:

- Virtually all media with the exception of powerful oxidisers.
- Header and footer rings for graphite ribbon packings like K3222 and K3222W

Properties:

- A graphite based high performance multiservice packing for both valve and pump applications
- The result is a high performance packing offering reliable sealing performance in both valve and pump applications.
- Also available with additional PTFE lubricant; Klinger K44PL

Typical Specifications:

Min. temperature	-240°C
Max. steam temperature	650°C
Max. temperature	430°C
Max. static pressure	150bar
Max. dynamic pressure	8bar
Max. speed	30m/s
pH range	0-14

The packing should not be subjected to the maximums of temperature, pressure and speed simultaneously.

Availability:

Size (mm)	Length (m)	Size (mm)	Length (m)
3,2 x 3,2	8	12,5 x 12,5	8
5,0 x 5,0	8	14,0 x 14,0	8
6,5 x 6,5	8	16,0 x 16,0	8
8,0 x 8,0	8	19,0 x 19,0	8
9,5 x 9,5	8	22,0 x 22,0	8
11,0 x 11,0	8	25,0 x 25,0	8

Carbon-fibre yarn with graphite and lubricant

Applications:

- A carbon fibre based high performance multiservice packing for both valve and pump applications
- Virtually all media with the exception of powerful oxidisers.
- Header and footer rings for graphite ribbon packings like K3222 and K3222W

Properties:

- The result is an economic alternative to pure graphite packings while offering reliable sealing performance in both valve and pump applications.
- A carbon based high performance multiservice packing for both valve and pump applications.

Typical Specifications:

Min. temperature	-240°C
Max. steam temperature	650°C
Max. temperature	430°C
Max. static pressure	200 bar
Max. speed	20m/s
pH range	0-14

The packing should not be subjected to the maximums of temperature, pressure and speed simultaneously.

Availability:

Size (mm)	Length (m)	Size (mm)	Length (m)
3,2 x 3,2	8	12,5 x 12,5	8
5,0 x 5,0	8	14,0 x 14,0	8
6,5 x 6,5	8	16,0 x 16,0	8
8,0 x 8,0	8	19,0 x 19,0	8
9,5 x 9,5	8	22,0 x 22,0	8
11,0 x 11,0	8	25,0 x 25,0	8

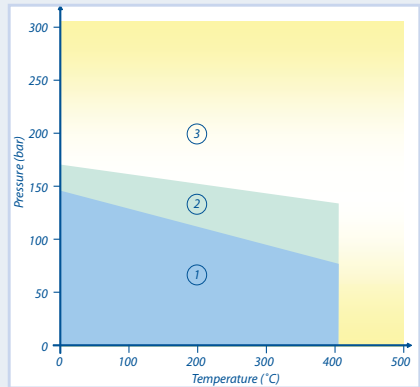

Pressure/Temperature Graph:

- Area 1: Usually satisfactory to use without reference.
- Area 2: Usually satisfactory, but suggest you refer to Klinger for advice.
- Area 3: Caution: May be suitable but essential that you refer to Klinger for advice.

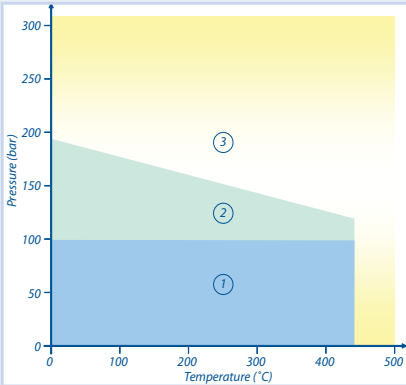

Pressure/Temperature Graph:

- Area 1: Usually satisfactory to use without reference.
- Area 2: Usually satisfactory, but suggest you refer to Klinger for advice.
- Area 3: Caution: May be suitable but essential that you refer to Klinger for advice.

Exfoliated graphite ribbon packing

Applications:

- A wide range of chemical media including steam, oils, grease and many acids and alkalis.

Properties:

- High performance valve and pump packing for high pressure, high temperature application. Offering excellent sealing and operational reliability for both Original Equipment Manufacturers and plant users alike.
- K3222 is manufactured using expanded graphite ribbons, to produce a compression packing of square cross-section that is fully flexible so that minimal gland pressure is required to effect a seal.
- K3222 is self-lubricating packing with superior gliding properties. It's soft, conformable nature ensures that there is no abrasion of moving parts and that graphite pick-up on stems and shafts is minimised

Typical Specifications:

Min. temperature	-200°C
Max. steam temperature	650°C
Max. temperature	430°C
Max. static pressure	280 bar
Max. speed	20m/s
pH range	0-14

The packing should not be subjected to the maximums of temperature, pressure and speed simultaneously.

Tests and Certifications:

- Fire-safe

Availability:

Size (mm)	Length (m)	Size (mm)	Length (m)
3,2 x 3,2	8	12,5 x 12,5	8
5,0 x 5,0	8	14,0 x 14,0	8
6,5 x 6,5	8	16,0 x 16,0	8
8,0 x 8,0	8	19,0 x 19,0	8
9,5 x 9,5	8	22,0 x 22,0	8
11,0 x 11,0	8	25,0 x 25,0	8

Inconel® reinforced exfoliated graphite ribbon packing

Applications:

- a wide range of chemical media including steam, oils, grease and many acids and alkalis.

Properties:

- High performance valve and pump packing for high pressure, high temperature application. Offering excellent sealing and operational reliability for both Original Equipment Manufacturers and plant users alike.
- The inclusion of Inconel® wire reinforcements ensures that the packing has excellent dimensional stability and will operate under the high stress conditions.

Typical Specifications:

Min. temperature	-200°C
Max. steam temperature	650°C
Max. temperature	430°C
Max. static pressure	300 bar
pH range	0-14
The packing should not be subjected to the maximums of temperature, pressure and speed simultaneously.	

Tests and Certifications:

- Fire-safe

Availability:

Size (mm)	Length (m)	Size (mm)	Length (m)
3,2 x 3,2	8	12,5 x 12,5	8
5,0 x 5,0	8	14,0 x 14,0	8
6,5 x 6,5	8	16,0 x 16,0	8
8,0 x 8,0	8	19,0 x 19,0	8
9,5 x 9,5	8	22,0 x 22,0	8
11,0 x 11,0	8	25,0 x 25,0	8

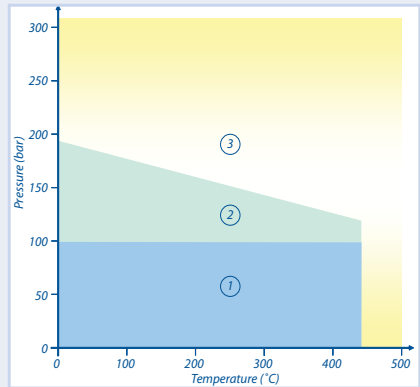

Pressure/Temperature Graph:

- Area 1: Usually satisfactory to use without reference.
- Area 2: Usually satisfactory, but suggest you refer to Klinger for advice.
- Area 3: Caution: May be suitable but essential that you refer to Klinger for advice.

Synthetic Packings



SYNTHETIC PACKINGS

An increasing variety of non-PTFE, non-carbon/graphite fibres, are employed in the production of mechanical compression packings. This is in response to the demand from industry for improvement in overall sealing capability. Ongoing development work is carried out by Klinger to evolve packing materials which offer improved sealing performance in a wide range of service environments.

It is recognised that these improvements take many forms but, in essence the users demand for less leakage, less downtime, less wear, combined with reasonable payback time, remains the primary criteria. These packings are increasingly finding favour because of the effective techniques employed by Klinger in respect of the materials used, and in braiding and lubrication methods.

General Properties:

- Each synthetic fibre yarn has unique sealing properties
- Improved performance allows the majority of sealing duties to be covered with the minimum of packing types
- Distinguished by their versatility - suitable for both valves and pumps
- Easy to cut and maintain

Packings Grades Available:

- K10
- K11
- K25
- K4303
- K4310
- K4333

Acrylic-fibre yarn with PTFE lubricant

Applications:

- A valve and pump packing suitable for a wide range of chemical media including steam, oil and hydrocarbons.

Properties:

- A combination of acrylic yarn and PTFE, producing an economic yet versatile synthetic packing, well suited to general service in valves and pumps.
- The Klingerlock construction ensures a firm yet conformable packing that requires little adjustment after the initial installation.
- The base yarn of Klinger K10 is spun from carefully selected acrylic filaments. To this we add a controlled amount of PTFE dispersion producing a packing that is ideally suited for general valve and pump use.

Typical Specifications:

Min. temperature	-100°C
Max. steam temperature	260°C
Max. temperature	260°C
Max. static pressure	100bar
Max. dynamic pressure	30bar
Max. speed	10m/s
pH range	2-12

The packing should not be subjected to the maximums of temperature, pressure and speed simultaneously.

Tests and Certifications:

- WRAS Approval for use with potable water

Availability:

Size (mm)	Length (m)	Size (mm)	Length (m)
3,2 x 3,2	8	12,5 x 12,5	8
5,0 x 5,0	8	14,0 x 14,0	8
6,5 x 6,5	8	16,0 x 16,0	8
8,0 x 8,0	8	19,0 x 19,0	8
9,5 x 9,5	8	22,0 x 22,0	8
11,0 x 11,0	8	25,0 x 25,0	8

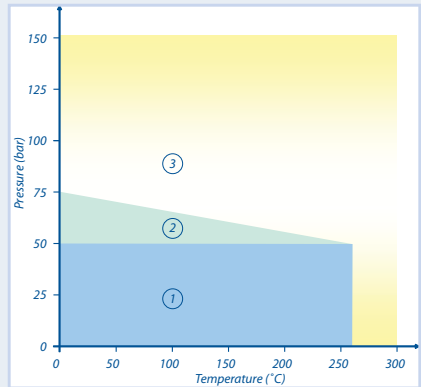

Pressure/Temperature Graph:

- Area 1: Usually satisfactory to use without reference.
- Area 2: Usually satisfactory, but suggest you refer to Klinger for advice.
- Area 3: Caution: May be suitable but essential that you refer to Klinger for advice.

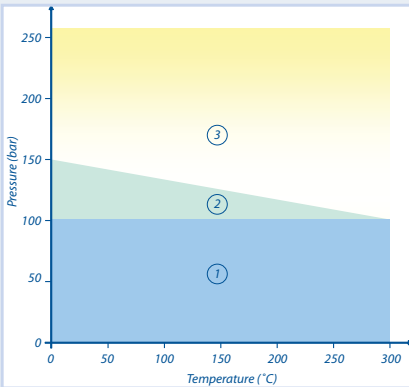

Pressure/Temperature Graph:

- Area 1: Usually satisfactory to use without reference.
- Area 2: Usually satisfactory, but suggest you refer to Klinger for advice.
- Area 3: Caution: May be suitable but essential that you refer to Klinger for advice.

Acrylic-fibre yarn with graphite lubricant

Applications:

- A specially developed synthetic packing offering high performance sealing within medium/high speed rotary applications.
- Moderate chemical environments.

Properties:

- The base yarn of Klinger K11 is spun from carefully selected acrylic filaments. To this we add a controlled amount of graphite dispersion producing a packing that is ideally suited for general valve and pump use.
- The packing's low coefficient of friction ensures easy operation and actuation of any valve or pump, without detrimental stem or shaft wear.
- The graphite dispersion enhances the chemical resistance of this packing allowing it to effectively seal the majority of chemical media commonly found within today's industrial environments

Typical Specifications:

Min. temperature	-100°C
Max. steam temperature	300°C
Max. temperature	300°C
Max. static pressure	100bar
Max. dynamic pressure	40bar
Max. speed	15m/s
pH range	4-10

The packing should not be subjected to the maximums of temperature, pressure and speed simultaneously.

Availability:

Size (mm)	Length (m)	Size (mm)	Length (m)
3,2 x 3,2	8	12,5 x 12,5	8
5,0 x 5,0	8	14,0 x 14,0	8
6,5 x 6,5	8	16,0 x 16,0	8
8,0 x 8,0	8	19,0 x 19,0	8
9,5 x 9,5	8	22,0 x 22,0	8
11,0 x 11,0	8	25,0 x 25,0	8

High-strength aramid yarns with PTFE lubricant

Applications:

- Suitable for a wide range of chemicals and where excellent dimensional stability is required.
- High-strength material yarns Klingerlock braided to produce a packing for sealing within extreme pumping applications - rotary or reciprocating.

Properties:

- Klinger K25 is manufactured from aramid yarns, to which we add PTFE as a break-in lubricant. The Klingerlock braiding process is used.
- K25 is very temperature tolerant and can operate effectively within a wide range.

Typical Specifications:

Min. temperature	-100°C
Max. steam temperature	280°C
Max. temperature	280°C
Max. dynamic pressure	30bar
Max. reciprocating pressure	100bar
Max. speed	20m/s
pH range	2-12

The packing should not be subjected to the maximums of temperature, pressure and speed simultaneously.

Tests and Certifications:

- WRAS Approval for use with potable water

Availability:

Size (mm)	Length (m)	Size (mm)	Length (m)
3,2 x 3,2	8	12,5 x 12,5	8
5,0 x 5,0	8	14,0 x 14,0	8
6,5 x 6,5	8	16,0 x 16,0	8
8,0 x 8,0	8	19,0 x 19,0	8
9,5 x 9,5	8	22,0 x 22,0	8
11,0 x 11,0	8	25,0 x 25,0	8

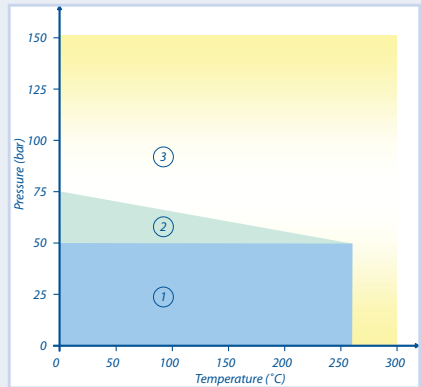
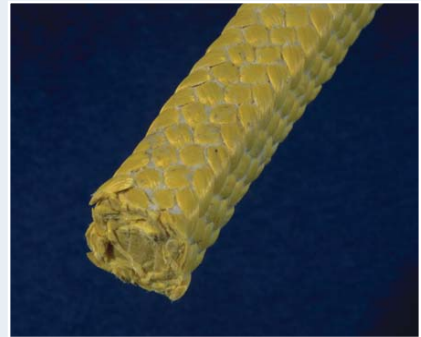

Pressure/Temperature Graph:

- Area 1: Usually satisfactory to use without reference.
- Area 2: Usually satisfactory, but suggest you refer to Klinger for advice.
- Area 3: Caution: May be suitable but essential that you refer to Klinger for advice.

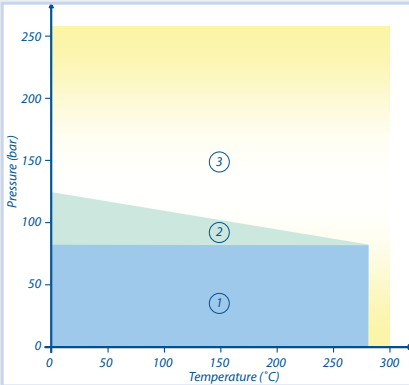

Pressure/Temperature Graph:

- Area 1: Usually satisfactory to use without reference.
- Area 2: Usually satisfactory, but suggest you refer to Klinger for advice.
- Area 3: Caution: May be suitable but essential that you refer to Klinger for advice.

Glass-fibre yarn with PTFE lubricant

Applications:

- A combination of selected glass fibre yarns and PTFE to produce a general valve and static seal packing
- Moderate chemical environments.

Properties:

- Klinger K4303, is a glass yarn packing with PTFE impregnation. The result is an efficient alternative to asbestos in valve applications and static sealing duties eg. caulking purposes.
- Glass fibres have superior thermal resistance, dimensional stability and excellent tensile strength. The addition of PTFE improves the overall chemical resistance of the packing while acting as a blocking agent to offer an economic seal without compromising leak-free performance

Typical Specifications:

Min. temperature	-100°C
Max. steam temperature	290°C
Max. temperature	290°C
Max. static pressure	80bar
Max. dynamic pressure	10bar
Max. speed	5m/s
pH range	4-12

The packing should not be subjected to the maximums of temperature, pressure and speed simultaneously.

Availability:

Size (mm)	Length (m)	Size (mm)	Length (m)
3,2 x 3,2	8	12,5 x 12,5	8
5,0 x 5,0	8	14,0 x 14,0	8
6,5 x 6,5	8	16,0 x 16,0	8
8,0 x 8,0	8	19,0 x 19,0	8
9,5 x 9,5	8	22,0 x 22,0	8
11,0 x 11,0	8	25,0 x 25,0	8

Glass-fibre yarns with added graphite lubricant

Applications:

- Suitable for water, steam, gas and oil.

Properties:

- Low cost, high temperature compression packing for effective and reliable sealing for valve stem glands.
- Klinger K4310, is a Klingerlock braided glass yarn packing with graphite lubricant impregnation. The result is an efficient alternative to asbestos in valve applications and static sealing duties eg. caulking purposes

Typical Specifications:

Min. temperature	-50°C
Max. steam temperature	450°C
Max. temperature	450°C
Max. static pressure	200bar
Max. dynamic pressure	20bar
Max. reciprocating pressure	30bar
Max. speed	5m/s
pH range	2-12

The packing should not be subjected to the maximums of temperature, pressure and speed simultaneously.

Availability:

Size (mm)	Length (m)	Size (mm)	Length (m)
3,2 x 3,2	8	12,5 x 12,5	8
5,0 x 5,0	8	14,0 x 14,0	8
6,5 x 6,5	8	16,0 x 16,0	8
8,0 x 8,0	8	19,0 x 19,0	8
9,5 x 9,5	8	22,0 x 22,0	8
11,0 x 11,0	8	25,0 x 25,0	8

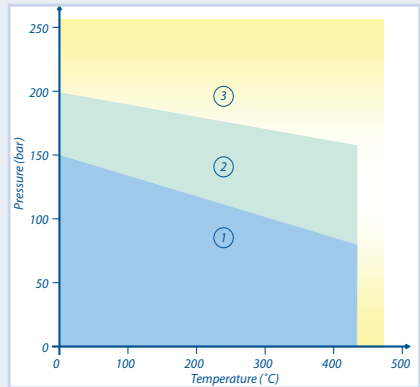

Pressure/Temperature Graph:

- Area 1: Usually satisfactory to use without reference.
- Area 2: Usually satisfactory, but suggest you refer to Klinger for advice.
- Area 3: Caution: May be suitable but essential that you refer to Klinger for advice.

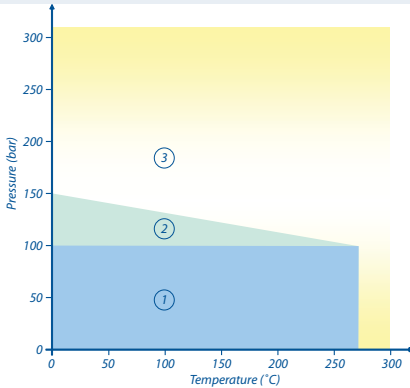
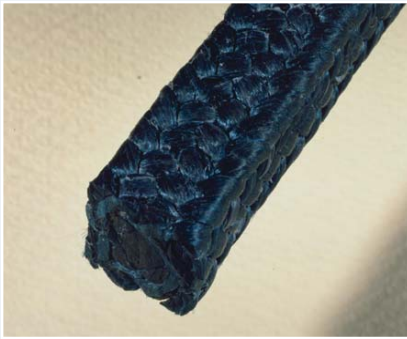

Pressure/Temperature Graph:

- Area 1: Usually satisfactory to use without reference.
- Area 2: Usually satisfactory, but suggest you refer to Klinger for advice.
- Area 3: Caution: May be suitable but essential that you refer to Klinger for advice.

Polyimide-fibre yarn with PTFE lubricant

Applications:

- Suitable for water, steam, oil, hydrocarbons and weak acids.

Properties:

- The base yarn of Klinger K4333 is composed of synthetic polyimide filaments which have excellent mechanical properties in terms of overall strength and elongation.
- K4333 is manufactured using the Klingerlock braiding process, during which we add an additional PTFE based lubricant. This enhances the packings performance in dynamic applications.
- The polyimide base structure of K4333 ensures the packing has excellent temperature resistance. Normally low gland loads will achieve a satisfactory seal.
- A universal packing, using lubricated polyimide filaments to produce a TopLine grade able to perform reliably in a wide range of services and equipment.

Typical Specifications:

Min. temperature	-80°C
Max. steam temperature	260°C
Max. temperature	260°C
Max. static pressure	200bar
Max. dynamic pressure	50bar
Max. speed	10m/s
pH range	0-13

The packing should not be subjected to the maximums of temperature, pressure and speed simultaneously.

Tests and Certifications:

- WRAS Approval for use with potable water

Availability:

Size (mm)	Length (m)	Size (mm)	Length (m)
3,2 x 3,2	8	12,5 x 12,5	8
5,0 x 5,0	8	14,0 x 14,0	8
6,5 x 6,5	8	16,0 x 16,0	8
8,0 x 8,0	8	19,0 x 19,0	8
9,5 x 9,5	8	22,0 x 22,0	8
11,0 x 11,0	8	25,0 x 25,0	8

Hybrid Packing



HYBRID PACKINGS

To suit those applications where an unusual combination of service demands is faced, a specially constructed hybrid packing may be required. This is usually achieved by combining two or more yarns by special braiding methods, and adding selected lubricants. These hybrid packings are primarily designed for use in specialised duties, but can be equally effective in many more standard applications. More importantly this combination of properties allows Hybrid compression packings to find use where traditional constructions have failed. Klinger recommend their use in difficult applications where high stresses are involved and the packing is required to offer a tight seal under high pressure, e.g. plunger / reciprocating pumps.

General Properties

- Hard wearing and long lasting
- Durable yet shaft protecting
- Wide chemical resistance
- High pressure rating
- Wide temperature band
- Conformable and easy to fit from roll
- Adaptable to a number of applications from static sealing through rotary and reciprocating

Packings Available

- K4311
- K4313

Aramid & PTFE yarn hybrid packing

Applications:

- A wide range of media including water, oils, solvents and weak acids and alkalis.

Properties:

- Hybrid packing that combines the properties of aramid and PTFE, resulting in a excellent product for high pressure valves and reciprocating duties.
- Klinger K4311 is manufactured from a combination of aramid and PTFE yarns using the Klingerlock braiding technique. The result is a packing with high resistance to extrusion that will operate at high peripheral speeds.
- The strong aramid corner posts resist extrusion from the stuffing box while ensuring that unwanted particles are excluded. This reduces the detrimental effects of abrasive and viscous media.

Typical Specifications:

Min. temperature	-100°C
Max. steam temperature	280°C
Max. temperature	280°C
Max. static pressure	250bar
Max. dynamic pressure	30bar
Max. reciprocating pressure	150bar
Max. speed	6m/s
pH range	2-12

The packing should not be subjected to the maximums of temperature, pressure and speed simultaneously.

Availability:

Size (mm)	Length (m)	Size (mm)	Length (m)
3,2 x 3,2	8	12,5 x 12,5	8
5,0 x 5,0	8	14,0 x 14,0	8
6,5 x 6,5	8	16,0 x 16,0	8
8,0 x 8,0	8	19,0 x 19,0	8
9,5 x 9,5	8	22,0 x 22,0	8
11,0 x 11,0	8	25,0 x 25,0	8

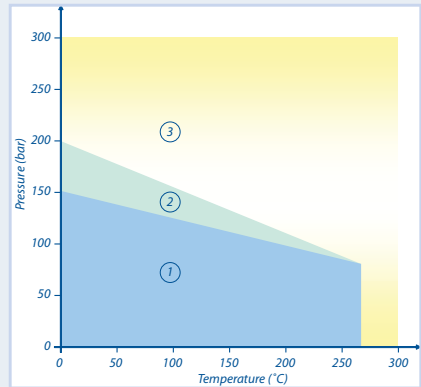
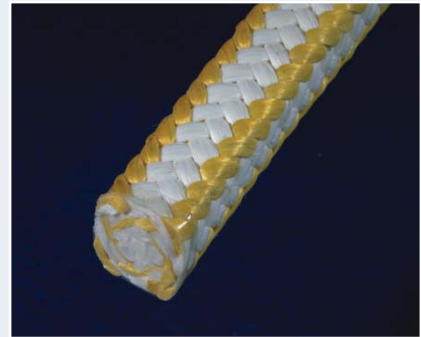

Pressure/Temperature Graph:

- Area 1: Usually satisfactory to use without reference.
- Area 2: Usually satisfactory, but suggest you refer to Klinger for advice.
- Area 3: Caution: May be suitable but essential that you refer to Klinger for advice.

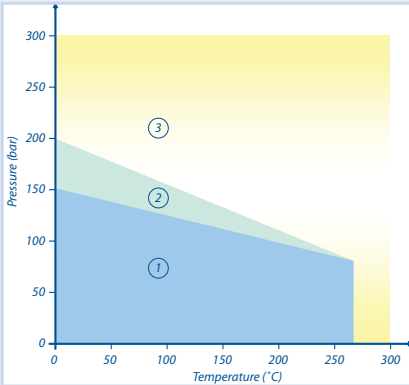

Pressure/Temperature Graph:

- Area 1: Usually satisfactory to use without reference.
- Area 2: Usually satisfactory, but suggest you refer to Klinger for advice.
- Area 3: Caution: May be suitable but essential that you refer to Klinger for advice.

Aramid & GORE™ GFO® yarn hybrid packing

Applications:

- A wide range of media including water, oils, solvents and weak acids and alkalis.

Properties:

- Hybrid packing that combines the properties of aramid and PTFE, resulting in an excellent product for high pressure valves and reciprocating duties.
- The PTFE/Graphite element, which is K4313's running surface, is soft and forgiving. Shaft wear is therefore kept to a minimum. It is a self-lubricating packing and has the ability to operate at temperatures up to 260°C
- Both constituents of Klinger K4313 enable this TopLine packing to resist attack from a wide range of media, including chemicals

Typical Specifications:

Min. temperature	-100°C
Max. steam temperature	280°C
Max. temperature	280°C
Max. static pressure	250bar
Max. dynamic pressure	25bar
Max. reciprocating pressure	350bar
Max. speed	20m/s
pH range	2-12

The packing should not be subjected to the maximums of temperature, pressure and speed simultaneously.

Availability:

Size (mm)	Length (m)	Size (mm)	Length (m)
3,2 x 3,2	8	12,5 x 12,5	8
5,0 x 5,0	8	14,0 x 14,0	8
6,5 x 6,5	8	16,0 x 16,0	8
8,0 x 8,0	8	19,0 x 19,0	8
9,5 x 9,5	8	22,0 x 22,0	8
11,0 x 11,0	8	25,0 x 25,0	8



O-Rings



Geopak Seals



Wiper Rings

Klinger Acorn Hydraulic Seals

Klinger Acorn Hydraulic Seals.....	239
Compound Selection.....	242
O-Rings; Typical Arrangements & Clearances.....	244
O-Ring Reference Guide	246
O-Ring Back-Up Rings.....	256
Contoured Back-Up Ring Reference Guide.....	257
Geopak Seals & Dimensional Reference Guide.....	260
Piston Seals	264
Wiper Rings.....	268
Flexi-Wear Rings.....	271
Bonded Washers.....	272
Celok Bonded Washers.....	272
Moulded Rubber Products.....	273
Chevron Seals.....	273
Super Lube Silicone Dielectric Grease.....	274
Super Lube Synthetic Oil with PTFE.....	275
Super Lube Multi-Purpose Grease.....	276
Super Lube Dri-Film	277
Super Lube Anti-Corrosion Grease.....	277
O-Ring Accessories.....	278
Chemical Resistance Chart For Hydraulic Seals	279

Nitrile (NBR)

Nitrile rubber, which has excellent resistance to petroleum products and fuel, has been the most widely used elastomer for sealing applications. It is a copolymer of acrylonitrile and butadiene, being available in various ratios of these two monomers. The formulations with a high ratio of acrylonitrile, over 50%, have strong resistance to oil and fuel. Those versions with over 78% of butadiene obtain good resistance to low temperatures, although they have to sacrifice some oil and fuel resistance at high temperatures.

In comparison to most elastomers, the NBR rubber's tensile strength, elongation properties, cold flow, compression set and resistance to oil, petroleum, tear and abrasion perform better than most. However, inherently special compounding is required increased weather ability and improved resistance to ozone and sunlight.

Ethylene Propylene (EPDM)

EPDM rubber is popular in the sealing industry due to its excellent resistance to Skydrol and other phosphate ester type hydraulic fluids. EPDM is often used in hot/cold water applications, steam and hydraulics systems, however EPDM has poor resistance to most oils, fuels and hydrocarbons.

EPDM rubbers have high tensile strength and elongation, with excellent resistance to oxygen, ozone and amongst the elastomers has exceptional resistance to weathering. EPDM has good recovery characteristics, low compression sealing, good heat resistance and good electrical resistance properties. EPDM service temperature range is approximately -50°C to 125°C.

Fluorocarbon (Viton)

Fluorocarbon rubbers are suitable for a wide range of service temperatures from approximately -20°C to 200°C. The temperature can be as high as 315°C for short periods and as low as -50°C in some static applications. Fluorocarbon rubber is growing in popularity as the market starts to acknowledge its potential uses with a wide spectrum of chemical compatibility and excellent resistance to oils, solvents, flames and heat. The petroleum, chemical and aviation industries have found them beneficial due to their resistance to hot engine lubricants. As time has progressed, newer formulations have tremendously improved the compression set characteristics and lower elongation properties. Due to their increased popularity more ranges of fluorocarbon O-Rings have been made more commercially available. Viton is a tradename of DuPont.

Neoprene (CR)

Neoprene rubbers are manufactured by polymerising chlorine and butadiene. They resist heat, oil, chemicals, ozone, weathering, flexing and compression set. Most elastomers are resistant to deterioration from exposure to petroleum lubricants and oxygen. Neoprene service temperature ranges from approximately -30°C to 110°C. Neoprene is a tradename of DuPont.

Polyurethane (PU)

Polyurethane is any polymer consisting of a chain of organic units joined together by urethane links. In the sealing industry polyurethane offers excellent abrasive resistance compared to rubber products, good load bearing capabilities, excellent dimensional stability under high pressures and is chemically resistant to solvents, oils, fuels, dilute acids and alkalis. Polyurethane is offered for heavy duty applications for pressures up to approximately 350bar. Polyurethane has reasonable low temperature resistance compared to elastomers with a service temperature approximately between -40°C to 90°C. Over 50°C in water submersion polyurethane is subjected to hydrolysis, causing the polymer to degrade.

Silicone (VMQ)

Silicone has an unusual molecular structure. This polymer consists of long chains of alternating silicone and oxygen, encased by organic groups. As a group, the silicones have poor tensile strength, tear and abrasion resistance. However, they have a broad service temperature range that far exceeds that of any other commercially available rubber. Silicones can be compounded to perform for extended periods at approximately -100°C to 315°C under static conditions, and at approximately -73°C to 315°C under dynamic conditions. Their retention of properties at these high temperatures is superior to other elastomers.

The compression set of silicone rubbers, as a measure of their perfect elasticity at any temperature, is equal or superior to that of any generally available elastomer. Silicone rubbers are odourless, tasteless and non-toxic. Due to their exceptional mechanical and electrical performance under extreme temperature conditions, silicone rubbers are widely used in hundreds of commercial and military applications. In many cases it is the inertness, non-toxicity, ease of processing and their resistance to heat, high aniline point oils, ozone and weathering that are also of critical importance. Silicone rubbers are not normally recommended for dynamic sealing due to the relatively low abrasion resistance.

Fluorosilicone (FVMQ)

Fluorosilicone is serviceable over a wide temperature range from approximately -60°C to 180°C. It has a relatively low tensile strength and elongation, but these properties are retained under a broad range of aging conditions. It combines the outstanding high and low temperature properties of silicone rubber with excellent swelling resistance to many commonly used fuels, oils and solvents. These rubbers also have low compression set, good electrical properties and excellent resistance to ozone and weathering. Fluorosilicone elastomers are not recommended for the use with ketones and phosphates esters.

Temperature Range

This chart is for reference only. In an actual service environment some specific compounds may not reach the maximum/minimum temperatures as indicated in this chart, however higher/lower temperatures may be attained if exposure is for short periods of time or intermittent use.

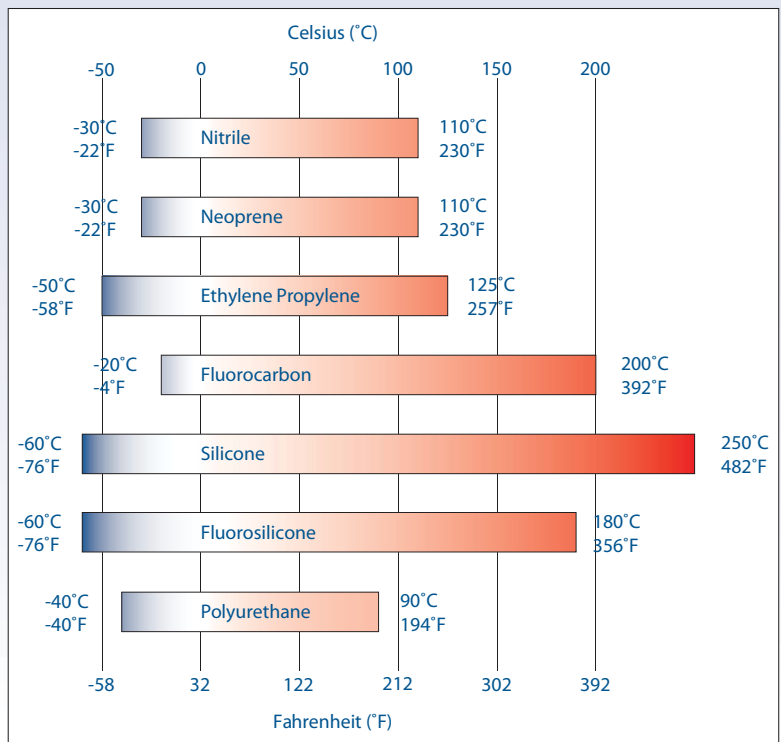

Klinger Acorn



Introduction

O-Rings are used as sealing elements or as energising wipers and hydraulic seals, so they cover an extensive number of applications. The simplistic design, ease of manufacture and compact design make O-Rings useful in nearly every field of industry. We offer a wide choice of elastomer materials in both standard and custom O-Rings for both static and dynamic applications.

Typical Reciprocating Seal Arrangement

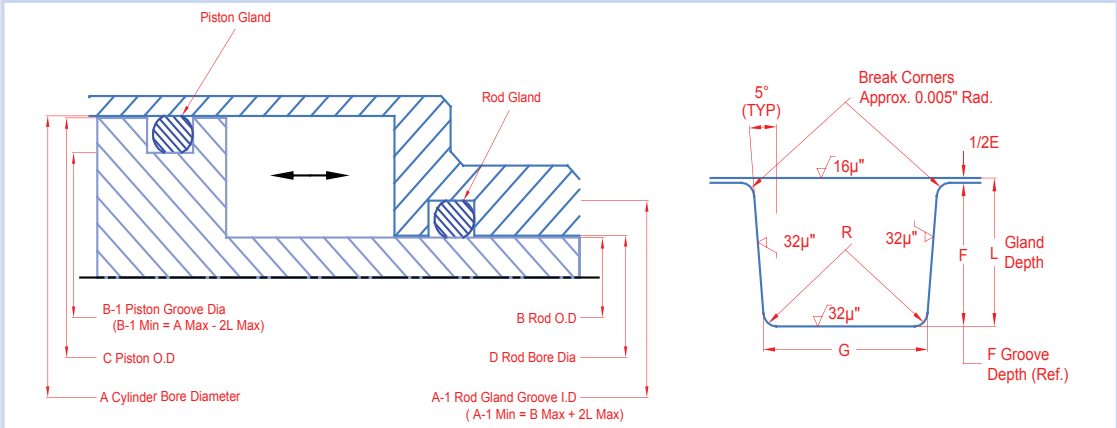

W, O-Ring Cross section	L, Groove Depth		Squeeze				E, Diametrical Clearance (Max)	G, Groove Width ± 0.005"			R, Groove Radius	Eccentricity (Max)
	Radial	Axial	Radial		Axial			No Back- Up Rings	One Back- Up Ring	Two Back- Up Rings		
			Inches	%	Inches	%						
0.07	0.049-0.055	0.045-0.050	0.012-0.014	18-19	0.017-0.028	25.5-38.5	0.004	0.095	0.140	0.207	0.005-0.015	0.002
0.103	0.080-0.086	0.072-0.080	0.014-0.026	13.5-25	0.020-0.034	20-32	0.005	0.142	0.173	0.240	0.005-0.015	0.002
0.139	0.122-0.118	0.100-0.110	0.017-0.031	12.5-29	0.025-0.043	18.5-30	0.006	0.189	0.210	0.277	0.010-0.025	0.003
0.210	0.176-0.184	0.165-0.175	0.021-0.039	10-18	0.030-0.050	14.5-23	0.006	0.283	0.313	0.413	0.020-0.035	0.004
0.275	0.225-0.235	0.220-0.230	0.034-0.056	12.5-20	0.039-0.061	14.5-21.5	0.007	0.377	0.410	0.540	0.020-0.035	0.005

All dimensions in Inches

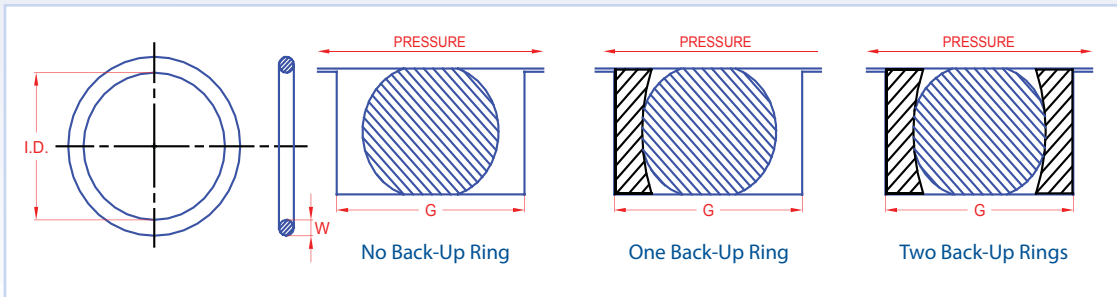



Typical Static Seal Arrangement

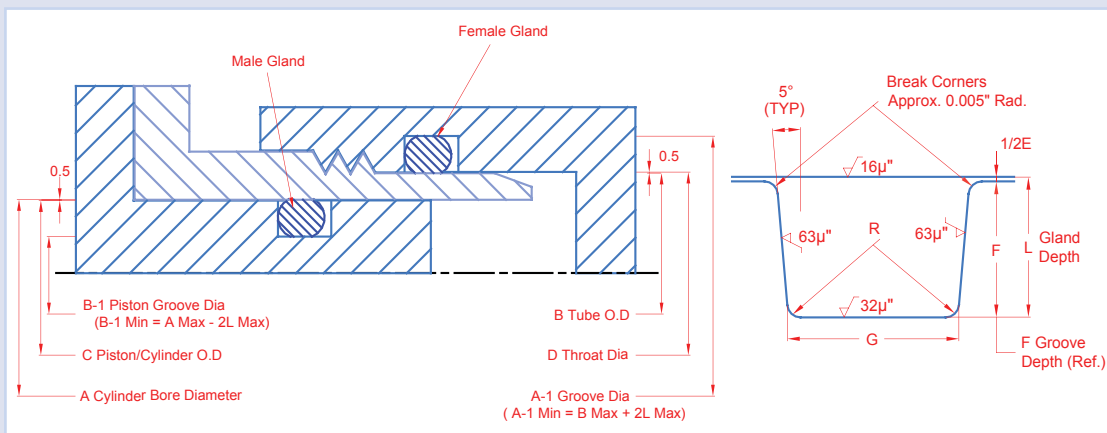

W, O-Ring Cross section	L, Groove Depth	Squeeze		E, Diametrical Clearance (Max)	G, Groove Width ± 0.005"			R, Groove Radius	Eccentricity (Max)
		Inches	%		No Back-Up Rings	One Back-Up Ring	Two Back-Up Rings		
0.07	0.055-0.057	0.010-0.018	15-25	0.004	0.095	0.140	0.207	0.005-0.015	0.002
0.103	0.087-0.090	0.010-0.019	10-18	0.005	0.142	0.173	0.240	0.005-0.015	0.002
0.139	0.119-0.123	0.012-0.24	9-17	0.006	0.189	0.210	0.277	0.010-0.025	0.003
0.210	0.183-0.188	0.017-0.032	8.5-15	0.006	0.283	0.313	0.413	0.020-0.035	0.004
0.275	0.234-0.240	0.029-0.047	10.5-17	0.007	0.377	0.410	0.540	0.020-0.035	0.005

All Dimensions in Inches

Klinger Acorn

O-RING REFERENCE GUIDE

O-Ring Reference number	Nominal Size (inches)			Standard O-Ring Size (Inches)				Metric O-Ring Size (mm)			
	Inches			Actual Per AS 568A				Actual Per AS 568A			
	ID	OD	W	ID	+/-	W	+/-	ID	+/-	W	+/-
BS-001	1/32	3/32	1/32	0.029	0.004	0.040	0.003	0.74	0.10	1.02	0.08
BS-002	3/64	9/64	3/64	0.042	0.004	0.050	0.003	1.07	0.10	1.27	0.08
BS-003	1/16	3/16	1/16	0.056	0.004	0.060	0.003	1.42	0.10	1.52	0.08
BS-004	5/64	13/64	1/16	0.070	0.005	0.070	0.003	1.78	0.13	1.78	0.08
BS-005	3/32	7/32	1/16	0.101	0.005	0.070	0.003	2.57	0.13	1.78	0.08
BS-006	1/8	1/4	1/16	0.114	0.005	0.070	0.003	2.90	0.13	1.78	0.08
BS-007	5/32	9/32	1/16	0.145	0.005	0.070	0.003	3.68	0.13	1.78	0.08
BS-008	3/16	5/16	1/16	0.176	0.005	0.070	0.003	4.47	0.13	1.78	0.08
BS-009	7/32	11/32	1/16	0.208	0.005	0.070	0.003	5.28	0.13	1.78	0.08
BS-010	1/4	3/8	1/16	0.239	0.005	0.070	0.003	6.07	0.13	1.78	0.08
BS-011	5/16	7/16	1/16	0.301	0.005	0.070	0.003	7.65	0.13	1.78	0.08
BS-012	3/8	1/2	1/16	0.364	0.005	0.070	0.003	9.25	0.13	1.78	0.08
BS-013	7/16	9/16	1/16	0.426	0.005	0.070	0.003	10.82	0.13	1.78	0.08
BS-014	1/2	5/8	1/16	0.489	0.005	0.070	0.003	12.42	0.13	1.78	0.08
BS-015	9/16	11/16	1/16	0.551	0.007	0.070	0.003	14.00	0.18	1.78	0.08
BS-016	5/8	3/4	1/16	0.614	0.009	0.070	0.003	15.60	0.23	1.78	0.08
BS-017	11/16	13/16	1/16	0.676	0.009	0.070	0.003	17.17	0.23	1.78	0.08
BS-018	3/4	7/8	1/16	0.739	0.009	0.070	0.003	18.77	0.23	1.78	0.08
BS-019	13/16	15/16	1/16	0.801	0.009	0.070	0.003	20.35	0.23	1.78	0.08
BS-020	7/8	1	1/16	0.864	0.009	0.070	0.003	21.95	0.23	1.78	0.08
BS-021	15/16	1 1/16	1/16	0.926	0.009	0.070	0.003	23.52	0.23	1.78	0.08
BS-022	1	1 1/8	1/16	0.989	0.010	0.070	0.003	25.12	0.25	1.78	0.08
BS-023	1 1/16	1 3/16	1/16	1.051	0.010	0.070	0.003	26.70	0.25	1.78	0.08
BS-024	1 1/8	1 1/4	1/16	1.114	0.010	0.070	0.003	28.30	0.25	1.78	0.08
BS-025	1 3/16	1 5/16	1/16	1.176	0.011	0.070	0.003	29.87	0.28	1.78	0.08
BS-026	1 1/4	1 3/8	1/16	1.239	0.011	0.070	0.003	31.47	0.28	1.78	0.08
BS-027	1 5/16	1 7/16	1/16	1.301	0.011	0.070	0.003	33.05	0.28	1.78	0.08
BS-028	1 3/8	1 1/2	1/16	1.364	0.013	0.070	0.003	34.65	0.33	1.78	0.08
BS-029	1 1/2	1 5/8	1/16	1.489	0.013	0.070	0.003	37.82	0.33	1.78	0.08
BS-030	1 5/8	1 3/4	1/16	1.614	0.013	0.070	0.003	41.00	0.33	1.78	0.08
BS-031	1 3/4	1 7/8	1/16	1.739	0.015	0.070	0.003	44.17	0.38	1.78	0.08
BS-032	1 7/8	2	1/16	1.864	0.015	0.070	0.003	47.35	0.38	1.78	0.08
BS-033	2	2 1/8	1/16	1.989	0.018	0.070	0.003	50.52	0.46	1.78	0.08
BS-034	2 1/8	2 1/4	1/16	2.114	0.018	0.070	0.003	53.70	0.46	1.78	0.08
BS-035	2 1/4	2 3/8	1/16	2.239	0.018	0.070	0.003	56.87	0.46	1.78	0.08
BS-036	2 3/8	2 1/2	1/16	2.364	0.018	0.070	0.003	60.05	0.46	1.78	0.08
BS-037	2 1/2	2 5/8	1/16	2.489	0.018	0.070	0.003	63.22	0.46	1.78	0.08
BS-038	2 5/8	2 3/4	1/16	2.614	0.020	0.070	0.003	66.40	0.51	1.78	0.08
BS-039	2 3/4	2 7/8	1/16	2.739	0.020	0.070	0.003	69.57	0.51	1.78	0.08
BS-040	2 7/8	3	1/16	2.864	0.020	0.070	0.003	72.75	0.61	1.78	0.08
BS-041	3	3 1/8	1/16	2.989	0.024	0.070	0.003	75.92	0.51	1.78	0.08
BS-042	3 1/4	3 3/8	1/16	3.239	0.024	0.070	0.003	82.27	0.61	1.78	0.08
BS-043	3 1/2	3 5/8	1/16	3.489	0.024	0.070	0.003	88.62	0.61	1.78	0.08
BS-044	3 3/4	3 7/8	1/16	3.739	0.027	0.070	0.003	94.97	0.69	1.78	0.08
BS-045	4	4 1/8	1/16	3.989	0.027	0.070	0.003	101.32	0.69	1.78	0.08
BS-046	4 1/4	4 3/8	1/16	4.239	0.030	0.070	0.003	107.67	0.76	1.78	0.08

O-Ring Reference number	Nominal Size (inches)			Standard O-Ring Size (Inches)				Metric O-Ring Size (mm)			
	Inches			Actual Per AS 568A				Actual Per AS 568A			
	ID	OD	W	ID	+/-	W	+/-	ID	+/-	W	+/-
BS-047	4 1/2	4 5/8	1/16	4.489	0.030	0.070	0.003	114.02	0.76	1.78	0.08
BS-048	4 3/4	4 7/8	1/16	4.739	0.030	0.070	0.003	120.37	0.76	1.78	0.08
BS-049	5	5 1/8	1/16	4.989	0.037	0.070	0.003	126.72	0.94	1.78	0.08
BS-050	5 1/4	5 3/8	1/16	5.239	0.037	0.070	0.003	133.07	0.94	1.78	0.08
BS-102	1/16	1/4	3/32	0.049	0.005	0.103	0.003	1.24	0.13	2.62	0.08
BS-103	3/32	9/32	3/32	0.081	0.005	0.103	0.003	2.06	0.13	2.62	0.08
BS-104	1/8	5/16	3/32	0.112	0.005	0.103	0.003	2.84	0.13	2.62	0.08
BS-105	5/32	11/32	3/32	0.143	0.005	0.103	0.003	3.63	0.13	2.62	0.08
BS-106	3/16	3/8	3/32	0.174	0.005	0.103	0.003	4.42	0.13	2.62	0.08
BS-107	7/32	13/32	3/32	0.206	0.005	0.103	0.003	5.23	0.13	2.62	0.08
BS-108	1/4	7/16	3/32	0.237	0.005	0.103	0.003	6.02	0.13	2.62	0.08
BS-109	5/16	1/2	3/32	0.299	0.005	0.103	0.003	7.59	0.13	2.62	0.08
BS-110	3/8	9/16	3/32	0.362	0.005	0.103	0.003	9.19	0.13	2.62	0.08
BS-111	7/16	5/8	3/32	0.424	0.005	0.103	0.003	10.77	0.13	2.62	0.08
BS-112	1/2	11/16	3/32	0.487	0.005	0.103	0.003	12.37	0.13	2.62	0.08
BS-113	9/16	3/4	3/32	0.549	0.007	0.103	0.003	13.94	0.18	2.62	0.08
BS-114	5/8	13/16	3/32	0.612	0.009	0.103	0.003	15.54	0.23	2.62	0.08
BS-115	11/16	7/8	3/32	0.674	0.009	0.103	0.003	17.12	0.23	2.62	0.08
BS-116	3/4	15/16	3/32	0.737	0.009	0.103	0.003	18.72	0.23	2.62	0.08
BS-117	13/16	1	3/32	0.799	0.010	0.103	0.003	20.30	0.25	2.62	0.08
BS-118	7/8	1 1/6	3/32	0.862	0.010	0.103	0.003	21.89	0.25	2.62	0.08
BS-119	15/16	1 1/8	3/32	0.924	0.010	0.103	0.003	23.47	0.25	2.62	0.08
BS-120	1	1 3/16	3/32	0.987	0.010	0.103	0.003	25.07	0.25	2.62	0.08
BS-121	1 1/16	1 1/4	3/32	1.049	0.010	0.103	0.003	26.64	0.25	2.62	0.08
BS-122	1 1/8	1 5/16	3/32	1.112	0.010	0.103	0.003	28.24	0.25	2.62	0.08
BS-123	1 3/16	1 3/8	3/32	1.174	0.012	0.103	0.003	29.82	0.30	2.62	0.08
BS-124	1 1/4	1 7/16	3/32	1.237	0.012	0.103	0.003	31.42	0.30	2.62	0.08
BS-125	1 5/16	1 1/2	3/32	1.299	0.012	0.103	0.003	32.99	0.30	2.62	0.08
BS-126	1 3/8	1 9/16	3/32	1.362	0.012	0.103	0.003	34.59	0.30	2.62	0.08
BS-127	1 7/16	1 5/8	3/32	1.424	0.012	0.103	0.003	36.17	0.30	2.62	0.08
BS-128	1 1/2	1 11/16	3/32	1.487	0.012	0.103	0.003	37.77	0.30	2.62	0.08
BS-129	1 9/16	1 3/4	3/32	1.549	0.015	0.103	0.003	39.34	0.38	2.62	0.08
BS-130	1 5/8	1 13/16	3/32	1.612	0.015	0.103	0.003	40.94	0.38	2.62	0.08
BS-131	1 11/16	1 7/8	3/32	1.674	0.015	0.103	0.003	42.52	0.38	2.62	0.08
BS-132	1 3/4	1 15/16	3/32	1.737	0.015	0.103	0.003	44.12	0.38	2.62	0.08
BS-133	1 13/16	2	3/32	1.799	0.015	0.103	0.003	45.69	0.38	2.62	0.08
BS-134	1 7/8	2 1/16	3/32	1.862	0.015	0.103	0.003	47.29	0.38	2.62	0.08
BS-135	1 15/16	2 1/8	3/32	1.925	0.017	0.103	0.003	48.90	0.43	2.62	0.08
BS-136	2	2 3/16	3/32	1.987	0.017	0.103	0.003	50.47	0.43	2.62	0.08
BS-137	2 1/16	2 1/4	3/32	2.050	0.017	0.103	0.003	52.07	0.43	2.62	0.08
BS-138	2 1/8	2 5/16	3/32	2.112	0.017	0.103	0.003	53.64	0.43	2.62	0.08
BS-139	2 3/16	2 3/8	3/32	2.175	0.017	0.103	0.003	55.25	0.43	2.62	0.08
BS-140	2 1/4	2 7/16	3/32	2.237	0.017	0.103	0.003	56.82	0.43	2.62	0.08
BS-141	2 5/16	2 1/2	3/32	2.300	0.020	0.103	0.003	58.42	0.51	2.62	0.08
BS-142	2 3/8	2 9/16	3/32	2.362	0.020	0.103	0.003	59.99	0.51	2.62	0.08
BS-143	2 7/16	2 5/8	3/32	2.425	0.020	0.103	0.003	61.60	0.51	2.62	0.08



O-RING REFERENCE GUIDE

O-Ring Reference number	Nominal Size (inches)			Standard O-Ring Size (Inches)				Metric O-Ring Size (mm)			
	Inches			Actual Per AS 568A				Actual Per AS 568A			
	ID	OD	W	ID	+/-	W	+/-	ID	+/-	W	+/-
BS-144	2 1/2	2 11/16	3/32	2.487	0.020	0.103	0.003	63.17	0.51	2.62	0.08
BS-145	2 9/16	2 3/4	3/32	2.550	0.020	0.103	0.003	64.77	0.51	2.62	0.08
BS-146	2 5/8	2 13/16	3/32	2.612	0.020	0.103	0.003	66.34	0.51	2.62	0.08
BS-147	2 11/16	2 7/8	3/32	2.675	0.022	0.103	0.003	67.95	0.56	2.62	0.08
BS-148	2 3/4	2 15/16	3/32	2.737	0.022	0.103	0.003	69.52	0.56	2.62	0.08
BS-149	2 13/16	3	3/32	2.800	0.022	0.103	0.003	71.12	0.56	2.62	0.08
BS-150	2 7/8	3 1/16	3/32	2.862	0.022	0.103	0.003	72.69	0.56	2.62	0.08
BS-151	3	3 3/16	3/32	2.987	0.024	0.103	0.003	75.87	0.61	2.62	0.08
BS-152	3 1/4	3 7/16	3/32	3.237	0.024	0.103	0.003	82.22	0.61	2.62	0.08
BS-153	3 1/2	3 11/16	3/32	3.487	0.024	0.103	0.003	88.57	0.61	2.62	0.08
BS-154	3 3/4	3 15/16	3/32	3.737	0.028	0.103	0.003	94.92	0.71	2.62	0.08
BS-155	4	4 3/16	3/32	3.987	0.028	0.103	0.003	101.27	0.71	2.62	0.08
BS-156	4 1/4	4 7/16	3/32	4.237	0.030	0.103	0.003	107.62	0.76	2.62	0.08
BS-157	4 1/2	4 11/16	3/32	4.487	0.030	0.103	0.003	113.97	0.76	2.62	0.08
BS-158	4 3/4	4 15/16	3/32	4.737	0.030	0.103	0.003	120.32	0.76	2.62	0.08
BS-159	5	5 3/16	3/32	4.987	0.035	0.103	0.003	126.67	0.89	2.62	0.08
BS-160	5 1/4	5 7/16	3/32	5.237	0.035	0.103	0.003	133.02	0.89	2.62	0.08
BS-161	5 1/2	5 11/16	3/32	5.487	0.035	0.103	0.003	139.37	0.89	2.62	0.08
BS-162	5 3/4	5 15/16	3/32	5.737	0.035	0.103	0.003	145.72	0.89	2.62	0.08
BS-163	6	6 3/16	3/32	5.987	0.035	0.103	0.003	152.07	0.89	2.62	0.08
BS-164	6 1/4	6 7/16	3/32	6.237	0.040	0.103	0.003	158.42	1.02	2.62	0.08
BS-165	6 1/2	6 11/16	3/32	6.487	0.040	0.103	0.003	164.77	1.02	2.62	0.08
BS-166	6 3/4	6 15/16	3/32	6.737	0.040	0.103	0.003	171.12	1.02	2.62	0.08
BS-167	7	7 3/16	3/32	6.987	0.040	0.103	0.003	177.47	1.02	2.62	0.08
BS-168	7 1/4	7 7/16	3/32	7.237	0.045	0.103	0.003	183.82	1.14	2.62	0.08
BS-169	7 1/2	7 11/16	3/32	7.487	0.045	0.103	0.003	190.17	1.14	2.62	0.08
BS-170	7 3/4	7 15/16	3/32	7.737	0.045	0.103	0.003	196.52	1.14	2.62	0.08
BS-171	8	8 3/16	3/32	7.987	0.045	0.103	0.003	202.87	1.14	2.62	0.08
BS-172	8 1/4	8 7/16	3/32	8.237	0.050	0.103	0.003	209.22	1.27	2.62	0.08
BS-173	8 1/2	8 11/16	3/32	8.487	0.050	0.103	0.003	215.57	1.27	2.62	0.08
BS-174	8 3/4	8 15/16	3/32	8.737	0.050	0.103	0.003	221.92	1.27	2.62	0.08
BS-175	9	9 3/16	3/32	8.987	0.050	0.103	0.003	228.27	1.27	2.62	0.08
BS-176	9 1/4	9 7/16	3/32	9.237	0.055	0.103	0.003	234.62	1.40	2.62	0.08
BS-177	9 1/2	9 11/16	3/32	9.487	0.055	0.103	0.003	240.97	1.40	2.62	0.08
BS-178	9 3/4	9 15/16	3/32	9.737	0.055	0.103	0.003	247.32	1.40	2.62	0.08
BS-201	3/16	7/16	1/8	0.171	0.005	0.139	0.004	4.34	0.13	3.53	0.10
BS-202	1/4	1/2	1/8	0.234	0.005	0.139	0.004	5.94	0.13	3.53	0.10
BS-203	5/16	9/16	1/8	0.296	0.005	0.139	0.004	7.52	0.13	3.53	0.10
BS-204	3/8	5/8	1/8	0.359	0.005	0.139	0.004	9.12	0.13	3.53	0.10
BS-205	7/16	11/16	1/8	0.421	0.005	0.139	0.004	10.69	0.13	3.53	0.10
BS-206	1/2	3/4	1/8	0.484	0.005	0.139	0.004	12.29	0.13	3.53	0.10
BS-207	9/16	13/16	1/8	0.546	0.007	0.139	0.004	13.87	0.18	3.53	0.10
BS-208	5/8	7/8	1/8	0.609	0.009	0.139	0.004	15.47	0.23	3.53	0.10
BS-209	11/16	15/16	1/8	0.671	0.010	0.139	0.004	17.04	0.23	3.53	0.10
BS-210	3/4	1	1/8	0.734	0.010	0.139	0.004	18.64	0.25	3.53	0.10
BS-211	13/16	1 1/16	1/8	0.796	0.010	0.139	0.004	20.22	0.25	3.53	0.10

O-Ring Reference number	Nominal Size (inches)			Standard O-Ring Size (Inches)				Metric O-Ring Size (mm)			
	Inches			Actual Per AS 568A				Actual Per AS 568A			
	ID	OD	W	ID	+/-	W	+/-	ID	+/-	W	+/-
BS-212	7/8	1 1/8	1/8	0.859	0.010	0.139	0.004	21.82	0.25	3.53	0.10
BS-213	15/16	1 3/16	1/8	0.921	0.010	0.139	0.004	23.39	0.25	3.53	0.10
BS-214	1	1 1/4	1/8	0.984	0.010	0.139	0.004	24.99	0.25	3.53	0.10
BS-215	1 1/16	1 5/16	1/8	1.046	0.010	0.139	0.004	26.57	0.25	3.53	0.10
BS-216	1 1/8	1 3/8	1/8	1.109	0.012	0.139	0.004	28.17	0.30	3.53	0.10
BS-217	1 3/16	1 7/16	1/8	1.171	0.012	0.139	0.004	29.74	0.30	3.53	0.10
BS-218	1 1/4	1 1/2	1/8	1.234	0.012	0.139	0.004	31.34	0.30	3.53	0.10
BS-219	1 5/16	1 9/16	1/8	1.296	0.012	0.139	0.004	32.92	0.30	3.53	0.10
BS-220	1 3/8	1 5/8	1/8	1.359	0.012	0.139	0.004	34.52	0.30	3.53	0.10
BS-221	1 7/16	1 11/16	1/8	1.421	0.012	0.139	0.004	36.09	0.30	3.53	0.10
BS-222	1 1/2	1 3/4	1/8	1.484	0.015	0.139	0.004	37.69	0.38	3.53	0.10
BS-223	1 5/8	1 7/8	1/8	1.609	0.015	0.139	0.004	40.87	0.38	3.53	0.10
BS-224	1 3/4	2	1/8	1.734	0.015	0.139	0.004	44.04	0.38	3.53	0.10
BS-225	1 7/8	2 1/8	1/8	1.859	0.018	0.139	0.004	47.22	0.46	3.53	0.10
BS-226	2	2 1/4	1/8	1.984	0.018	0.139	0.004	50.39	0.46	3.53	0.10
BS-227	2 1/8	2 3/8	1/8	2.109	0.018	0.139	0.004	53.57	0.46	3.53	0.10
BS-228	2 1/4	2 1/2	1/8	2.234	0.020	0.139	0.004	56.74	0.51	3.53	0.10
BS-229	2 3/8	2 5/8	1/8	2.359	0.020	0.139	0.004	59.92	0.51	3.53	0.10
BS-230	2 1/2	2 3/4	1/8	2.484	0.020	0.139	0.004	63.09	0.51	3.53	0.10
BS-231	2 5/8	2 7/8	1/8	2.609	0.020	0.139	0.004	66.27	0.51	3.53	0.10
BS-232	2 3/4	3	1/8	2.734	0.024	0.139	0.004	69.44	0.61	3.53	0.10
BS-233	2 7/8	3 1/8	1/8	2.859	0.024	0.139	0.004	72.62	0.61	3.53	0.10
BS-234	3	3 1/4	1/8	2.984	0.024	0.139	0.004	75.79	0.61	3.53	0.10
BS-235	3 1/8	3 3/8	1/8	3.109	0.024	0.139	0.004	78.97	0.61	3.53	0.10
BS-236	3 1/4	3 1/2	1/8	3.234	0.024	0.139	0.004	82.14	0.61	3.53	0.10
BS-237	3 3/8	3 5/8	1/8	3.359	0.024	0.139	0.004	85.32	0.61	3.53	0.10
BS-238	3 1/2	3 3/4	1/8	3.484	0.024	0.139	0.004	88.49	0.61	3.53	0.10
BS-239	3 5/8	3 7/8	1/8	3.609	0.028	0.139	0.004	91.67	0.71	3.53	0.10
BS-240	3 3/4	4	1/8	3.734	0.028	0.139	0.004	94.84	0.71	3.53	0.10
BS-241	3 7/8	4 1/8	1/8	3.859	0.028	0.139	0.004	98.02	0.71	3.53	0.10
BS-242	4	4 1/4	1/8	3.984	0.028	0.139	0.004	101.19	0.71	3.53	0.10
BS-243	4 1/8	4 3/8	1/8	4.109	0.028	0.139	0.004	104.37	0.71	3.53	0.10
BS-244	4 1/4	4 1/2	1/8	4.234	0.030	0.139	0.004	107.54	0.76	3.53	0.10
BS-245	4 3/8	4 5/8	1/8	4.359	0.030	0.139	0.004	110.72	0.76	3.53	0.10
BS-246	4 1/2	4 3/4	1/8	4.484	0.030	0.139	0.004	113.89	0.76	3.53	0.10
BS-247	4 5/8	4 7/8	1/8	4.609	0.030	0.139	0.004	117.07	0.76	3.53	0.10
BS-248	4 3/4	5	1/8	4.734	0.030	0.139	0.004	120.24	0.76	3.53	0.10
BS-249	4 7/8	5 1/8	1/8	4.859	0.035	0.139	0.004	123.42	0.89	3.53	0.10
BS-250	5	5 1/4	1/8	4.984	0.035	0.139	0.004	126.59	0.89	3.53	0.10
BS-251	5 1/8	5 3/8	1/8	5.109	0.035	0.139	0.004	129.77	0.89	3.53	0.10
BS-252	5 1/4	5 1/2	1/8	5.234	0.035	0.139	0.004	132.94	0.89	3.53	0.10
BS-253	5 3/8	5 5/8	1/8	5.359	0.035	0.139	0.004	136.12	0.89	3.53	0.10
BS-254	5 1/2	5 3/4	1/8	5.484	0.035	0.139	0.004	139.29	0.89	3.53	0.10
BS-255	5 5/8	5 7/8	1/8	5.609	0.035	0.139	0.004	142.47	0.89	3.53	0.10
BS-256	5 3/4	6	1/8	5.734	0.035	0.139	0.004	145.64	0.89	3.53	0.10
BS-257	5 7/8	6 1/8	1/8	5.859	0.035	0.139	0.004	148.82	0.89	3.53	0.10

O-RING REFERENCE GUIDE

O-Ring Reference number	Nominal Size (inches)			Standard O-Ring Size (Inches)				Metric O-Ring Size (mm)			
	Inches			Actual Per AS 568A				Actual Per AS 568A			
	ID	OD	W	ID	+/-	W	+/-	ID	+/-	W	+/-
BS-258	6	6 1/4	1/8	5.984	0.035	0.139	0.004	151.99	0.89	3.53	0.10
BS-259	6 1/4	6 1/2	1/8	6.234	0.040	0.139	0.004	158.34	1.02	3.53	0.10
BS-260	6 1/2	6 3/4	1/8	6.484	0.040	0.139	0.004	164.69	1.02	3.53	0.10
BS-261	6 3/4	7	1/8	6.734	0.040	0.139	0.004	171.04	1.02	3.53	0.10
BS-262	7	7 1/4	1/8	6.984	0.040	0.139	0.004	177.39	1.02	3.53	0.10
BS-263	7 1/4	7 1/2	1/8	7.234	0.045	0.139	0.004	183.74	1.14	3.53	0.10
BS-264	7 1/2	7 3/4	1/8	7.484	0.045	0.139	0.004	190.09	1.14	3.53	0.10
BS-265	7 3/4	8	1/8	7.734	0.045	0.139	0.004	196.44	1.14	3.53	0.10
BS-266	8	8 1/4	1/8	7.984	0.045	0.139	0.004	202.79	1.14	3.53	0.10
BS-267	8 1/4	8 1/2	1/8	8.234	0.050	0.139	0.004	209.14	1.27	3.53	0.10
BS-268	8 1/2	8 3/4	1/8	8.484	0.050	0.139	0.004	215.49	1.27	3.53	0.10
BS-269	8 3/4	9	1/8	8.734	0.050	0.139	0.004	221.84	1.27	3.53	0.10
BS-270	9	9 1/4	1/8	8.984	0.050	0.139	0.004	228.19	1.27	3.53	0.10
BS-271	9 1/4	9 1/2	1/8	9.234	0.055	0.139	0.004	234.54	1.40	3.53	0.10
BS-272	9 1/2	9 3/4	1/8	9.484	0.055	0.139	0.004	240.89	1.40	3.53	0.10
BS-273	9 3/4	10	1/8	9.734	0.055	0.139	0.004	247.24	1.40	3.53	0.10
BS-274	10	10 1/4	1/8	9.984	0.055	0.139	0.004	253.59	1.40	3.53	0.10
BS-275	10 1/2	10 3/4	1/8	10.484	0.055	0.139	0.004	266.29	1.40	3.53	0.10
BS-276	11	11 1/4	1/8	10.984	0.065	0.139	0.004	278.99	1.65	3.53	0.10
BS-277	11 1/2	11 3/4	1/8	11.484	0.065	0.139	0.004	291.69	1.65	3.53	0.10
BS-278	12	12 1/4	1/8	11.984	0.065	0.139	0.004	304.39	1.65	3.53	0.10
BS-279	13	13 1/4	1/8	12.984	0.065	0.139	0.004	329.79	1.65	3.53	0.10
BS-280	14	14 1/4	1/8	13.984	0.065	0.139	0.004	355.19	1.65	3.53	0.10
BS-281	15	15 1/4	1/8	14.984	0.065	0.139	0.004	380.59	1.65	3.53	0.10
BS-282	16	16 1/4	1/8	15.955	0.075	0.139	0.004	405.26	1.91	3.53	0.10
BS-283	17	17 1/4	1/8	16.955	0.080	0.139	0.004	430.66	2.03	3.53	0.10
BS-284	18	18 1/4	1/8	17.955	0.085	0.139	0.004	456.06	2.16	3.53	0.10
BS-309	7/16	13/16	3/16	0.412	0.005	0.210	0.005	10.46	0.13	5.33	0.13
BS-310	1/2	7/8	3/16	0.475	0.005	0.210	0.005	12.07	0.13	5.33	0.13
BS-311	9/16	15/16	3/16	0.537	0.007	0.210	0.005	13.64	0.18	5.33	0.13
BS-312	5/8	1	3/16	0.600	0.009	0.210	0.005	15.24	0.23	5.53	0.13
BS-313	11/16	1 1/16	3/16	0.662	0.009	0.210	0.005	16.81	0.23	5.33	0.13
BS-314	3/4	1 1/8	3/16	0.725	0.010	0.210	0.005	18.42	0.25	5.33	0.13
BS-315	13/16	1 3/16	3/16	0.787	0.010	0.210	0.005	19.99	0.25	5.33	0.13
BS-316	7/8	1 1/4	3/16	0.85	0.010	0.210	0.005	21.59	0.25	5.33	0.13
BS-317	15/16	1 5/16	3/16	0.912	0.010	0.210	0.005	23.16	0.25	5.33	0.13
BS-318	1	1 3/8	3/16	0.975	0.010	0.210	0.005	24.77	0.25	5.53	0.13
BS-319	1 1/16	1 7/16	3/16	1.037	0.010	0.210	0.005	26.34	0.25	5.33	0.13
BS-320	1 1/8	1 1/2	3/16	1.100	0.012	0.210	0.005	27.94	0.30	5.33	0.13
BS-321	1 3/16	1 9/16	3/16	1.162	0.012	0.210	0.005	29.51	0.30	5.33	0.13
BS-322	1 1/4	1 5/8	3/16	1.225	0.012	0.210	0.005	31.12	0.30	5.33	0.13
BS-323	1 5/16	1 11/16	3/16	1.287	0.012	0.210	0.005	32.69	0.30	5.53	0.13
BS-324	1 3/8	1 3/4	3/16	1.350	0.012	0.210	0.005	34.29	0.30	5.33	0.13
BS-325	1 1/2	1 7/8	3/16	1.475	0.015	0.210	0.005	37.47	0.38	5.33	0.13
BS-326	1 5/8	2	3/16	1.600	0.015	0.210	0.005	40.64	0.38	5.33	0.13
BS-327	1 3/4	2 1/8	3/16	1.725	0.015	0.210	0.005	43.82	0.38	5.33	0.13

O-Ring Reference number	Nominal Size (inches)			Standard O-Ring Size (Inches)				Metric O-Ring Size (mm)			
	Inches			Actual Per AS 568A				Actual Per AS 568A			
	ID	OD	W	ID	+/-	W	+/-	ID	+/-	W	+/-
BS-328	1 7/8	2 1/4	3/16	1.850	0.015	0.210	0.005	46.99	0.38	5.53	0.13
BS-329	2	2 3/8	3/16	1.975	0.018	0.210	0.005	50.17	0.46	5.33	0.13
BS-330	2 1/8	2 1/2	3/16	2.100	0.018	0.210	0.005	53.34	0.46	5.33	0.13
BS-331	2 1/4	2 5/8	3/16	2.225	0.018	0.210	0.005	56.52	0.46	5.33	0.13
BS-332	2 3/8	2 3/4	3/16	2.350	0.018	0.210	0.005	59.69	0.46	5.33	0.13
BS-333	2 1/2	2 7/8	3/16	2.475	0.020	0.210	0.005	62.87	0.51	5.53	0.13
BS-334	2 5/8	3	3/16	2.600	0.020	0.210	0.005	66.04	0.51	5.33	0.13
BS-335	2 3/4	3 1/8	3/16	2.725	0.020	0.210	0.005	69.22	0.51	5.33	0.13
BS-336	2 7/8	3 1/4	3/16	2.850	0.020	0.210	0.005	72.39	0.51	5.33	0.13
BS-337	3	3 3/8	3/16	2.975	0.024	0.210	0.005	75.57	0.61	5.33	0.13
BS-338	3 1/8	3 1/2	3/16	3.100	0.024	0.210	0.005	78.74	0.61	5.53	0.13
BS-339	3 1/4	3 5/8	3/16	3.225	0.024	0.210	0.005	81.92	0.61	5.33	0.13
BS-340	3 3/8	3 3/4	3/16	3.350	0.024	0.210	0.005	85.09	0.61	5.33	0.13
BS-341	3 1/2	3 7/8	3/16	3.475	0.024	0.210	0.005	88.27	0.61	5.33	0.13
BS-342	3 5/8	4	3/16	3.600	0.028	0.210	0.005	91.44	0.71	5.33	0.13
BS-343	3 3/4	4 1/8	3/16	3.725	0.028	0.210	0.005	94.62	0.71	5.53	0.13
BS-344	3 7/8	4 1/4	3/16	3.850	0.028	0.210	0.005	97.79	0.71	5.33	0.13
BS-345	4	4 3/8	3/16	3.975	0.028	0.210	0.005	100.97	0.71	5.33	0.13
BS-346	4 1/8	4 1/2	3/16	4.100	0.028	0.210	0.005	104.14	0.71	5.33	0.13
BS-347	4 1/4	4 5/8	3/16	4.225	0.030	0.210	0.005	107.32	0.76	5.33	0.13
BS-348	4 3/8	4 3/4	3/16	4.350	0.030	0.210	0.005	110.49	0.76	5.53	0.13
BS-349	4 1/2	4 7/8	3/16	4.475	0.030	0.210	0.005	113.67	0.76	5.33	0.13
BS-350	4 5/8	5	3/16	4.600	0.030	0.210	0.005	116.84	0.76	5.33	0.13
BS-351	4 3/4	5 1/8	3/16	4.725	0.030	0.210	0.005	120.02	0.76	5.33	0.13
BS-352	4 7/8	5 1/4	3/16	4.850	0.030	0.210	0.005	123.19	0.76	5.33	0.13
BS-353	5	5 3/8	3/16	4.975	0.037	0.210	0.005	126.37	0.94	5.33	0.13
BS-354	5 1/8	5 1/2	3/16	5.100	0.037	0.210	0.005	129.54	0.94	5.53	0.13
BS-355	5 1/4	5 5/8	3/16	5.225	0.037	0.210	0.005	132.72	0.94	5.33	0.13
BS-356	5 3/8	5 3/4	3/16	5.350	0.037	0.210	0.005	135.89	0.94	5.33	0.13
BS-357	5 1/2	5 7/8	3/16	5.475	0.037	0.210	0.005	139.07	0.94	5.33	0.13
BS-358	5 5/8	6	3/16	5.600	0.037	0.210	0.005	142.24	0.94	5.33	0.13
BS-359	5 3/4	6 1/8	3/16	5.725	0.037	0.210	0.005	145.42	0.94	5.53	0.13
BS-360	5 7/8	6 1/4	3/16	5.850	0.037	0.210	0.005	148.59	0.94	5.33	0.13
BS-361	6	6 3/8	3/16	5.975	0.037	0.210	0.005	151.77	0.94	5.33	0.13
BS-362	6 1/4	6 5/8	3/16	6.225	0.040	0.210	0.005	158.12	1.02	5.33	0.13
BS-363	6 1/2	6 7/8	3/16	6.475	0.040	0.210	0.005	164.47	1.02	5.33	0.13
BS-364	6 3/4	7 1/8	3/16	6.725	0.040	0.210	0.005	170.82	1.02	5.53	0.13
BS-365	7	7 3/8	3/16	6.975	0.040	0.210	0.005	177.17	1.02	5.33	0.13
BS-366	7 1/4	7 5/8	3/16	7.225	0.045	0.210	0.005	183.52	1.14	5.33	0.13
BS-367	7 1/2	7 7/8	3/16	7.475	0.045	0.210	0.005	189.87	1.14	5.33	0.13
BS-368	7 3/4	8 1/8	3/16	7.725	0.045	0.210	0.005	196.22	1.14	5.33	0.13
BS-369	8	8 3/8	3/16	7.975	0.045	0.210	0.005	202.57	1.14	5.53	0.13
BS-370	8 1/4	8 5/8	3/16	8.225	0.050	0.210	0.005	208.92	1.27	5.33	0.13
BS-371	8 1/2	8 7/8	3/16	8.475	0.050	0.210	0.005	215.27	1.27	5.33	0.13
BS-372	8 3/4	9 1/8	3/16	8.725	0.050	0.210	0.005	221.62	1.27	5.33	0.13
BS-373	9	9 3/8	3/16	8.975	0.050	0.210	0.005	227.97	1.27	5.33	0.13

O-RING REFERENCE GUIDE

O-Ring Reference number	Nominal Size (inches)			Standard O-Ring Size (Inches)				Metric O-Ring Size (mm)			
	Inches			Actual Per AS 568A				Actual Per AS 568A			
	ID	OD	W	ID	+/-	W	+/-	ID	+/-	W	+/-
BS-374	9 1/4	9 5/8	3/16	9.225	0.055	0.210	0.005	234.32	1.40	5.53	0.13
BS-375	9 1/2	9 7/8	3/16	9.475	0.055	0.210	0.005	240.67	1.40	5.33	0.13
BS-376	9 3/4	10 1/8	3/16	9.725	0.055	0.210	0.005	247.02	1.40	5.33	0.13
BS-377	10	10 3/8	3/16	9.975	0.055	0.210	0.005	253.37	1.40	5.33	0.13
BS-378	10 1/2	10 7/8	3/16	10.475	0.060	0.210	0.005	266.07	1.52	5.33	0.13
BS-379	11	11 3/8	3/16	10.975	0.060	0.210	0.005	278.77	1.52	5.53	0.13
BS-380	11 1/2	11 7/8	3/16	11.475	0.065	0.210	0.005	291.47	1.65	5.33	0.13
BS-381	12	12 3/8	3/16	11.975	0.065	0.210	0.005	304.17	1.65	5.33	0.13
BS-382	13	13 3/8	3/16	12.975	0.065	0.210	0.005	329.57	1.65	5.33	0.13
BS-383	14	14 3/8	3/16	13.975	0.070	0.210	0.005	354.97	1.78	5.33	0.13
BS-384	15	15 3/8	3/16	14.975	0.070	0.210	0.005	380.37	1.78	5.53	0.13
BS-385	16	16 3/8	3/16	15.955	0.075	0.210	0.005	405.26	1.91	5.33	0.13
BS-386	17	17 3/8	3/16	16.955	0.080	0.210	0.005	430.66	2.03	5.33	0.13
BS-387	18	18 3/8	3/16	17.955	0.085	0.210	0.005	456.06	2.16	5.33	0.13
BS-388	19	19 3/8	3/16	18.955	0.090	0.210	0.005	481.41	2.29	5.33	0.13
BS-389	20	20 3/8	3/16	19.955	0.095	0.210	0.005	506.81	2.41	5.53	0.13
BS-390	21	21 3/8	3/16	20.955	0.095	0.210	0.005	532.21	2.41	5.33	0.13
BS-391	22	22 3/8	3/16	21.955	0.100	0.210	0.005	557.61	2.54	5.33	0.13
BS-392	23	23 3/8	3/16	22.940	0.105	0.210	0.005	582.68	2.67	5.33	0.13
BS-393	24	24 3/8	3/16	23.940	0.110	0.210	0.005	608.08	2.79	5.33	0.13
BS-394	25	25 3/8	3/16	24.940	0.115	0.210	0.005	633.48	2.92	5.33	0.13
BS-395	26	26 3/8	3/16	25.940	0.120	0.210	0.005	658.88	3.05	5.33	0.13
BS-425	4 1/2	5	1/4	4.475	0.033	0.275	0.006	113.67	0.84	6.99	0.15
BS-426	4 5/8	5 1/8	1/4	4.600	0.033	0.275	0.006	116.84	0.84	6.99	0.15
BS-427	4 3/4	5 1/4	1/4	4.725	0.033	0.275	0.006	120.02	0.84	6.99	0.15
BS-428	4 7/8	5 3/8	1/4	4.850	0.033	0.275	0.006	123.19	0.84	6.99	0.15
BS-429	5	5 1/2	1/4	4.975	0.037	0.275	0.006	126.37	0.94	6.99	0.15
BS-430	5 1/8	5 5/8	1/4	5.100	0.037	0.275	0.006	129.54	0.94	6.99	0.15
BS-431	5 1/4	5 3/4	1/4	5.225	0.037	0.275	0.006	132.72	0.94	6.99	0.15
BS-432	5 3/8	5 7/8	1/4	5.350	0.037	0.275	0.006	135.89	0.94	6.99	0.15
BS-433	5 1/2	6	1/4	5.475	0.037	0.275	0.006	139.07	0.94	6.99	0.15
BS-434	5 5/8	6 1/8	1/4	5.600	0.037	0.275	0.006	142.24	0.94	6.99	0.15
BS-435	5 3/4	6 1/4	1/4	5.725	0.037	0.275	0.006	145.42	0.94	6.99	0.15
BS-436	5 7/8	6 3/8	1/4	5.850	0.037	0.275	0.006	148.59	0.94	6.99	0.15
BS-437	6	6 1/2	1/4	5.975	0.037	0.275	0.006	151.77	0.94	6.99	0.15
BS-438	6 1/4	6 3/4	1/4	6.225	0.040	0.275	0.006	158.12	1.02	6.99	0.15
BS-439	6 1/2	7	1/4	6.475	0.040	0.275	0.006	164.47	1.02	6.99	0.15
BS-440	6 3/4	7 1/4	1/4	6.725	0.040	0.275	0.006	170.82	1.02	6.99	0.15
BS-441	7	7 1/2	1/4	6.975	0.040	0.275	0.006	177.17	1.02	6.99	0.15
BS-442	7 1/4	7 3/4	1/4	7.225	0.045	0.275	0.006	183.52	1.14	6.99	0.15
BS-443	7 1/2	8	1/4	7.475	0.045	0.275	0.006	189.87	1.14	6.99	0.15
BS-444	7 3/4	8 1/4	1/4	7.725	0.045	0.275	0.006	196.22	1.14	6.99	0.15
BS-445	8	8 1/2	1/4	7.975	0.045	0.275	0.006	202.57	1.14	6.99	0.15
BS-446	8 1/2	9	1/4	8.475	0.055	0.275	0.006	215.27	1.40	6.99	0.15
BS-447	9	9 1/2	1/4	8.975	0.055	0.275	0.006	227.97	1.40	6.99	0.15
BS-448	9 1/2	10	1/4	9.475	0.055	0.275	0.006	240.67	1.40	6.99	0.15

O-Ring Reference number	Nominal Size (inches)			Standard O-Ring Size (Inches)				Metric O-Ring Size (mm)			
	Inches			Actual Per AS 568A				Actual Per AS 568A			
	ID	OD	W	ID	+/-	W	+/-	ID	+/-	W	+/-
BS-449	10	10 1/2	1/4	9.975	0.055	0.275	0.006	253.37	1.40	6.99	0.15
BS-450	10 1/2	11	1/4	10.475	0.060	0.275	0.006	266.07	1.52	6.99	0.15
BS-451	11	11 1/2	1/4	10.975	0.060	0.275	0.006	278.77	1.52	6.99	0.15
BS-452	11 1/2	12	1/4	11.475	0.060	0.275	0.006	291.47	1.52	6.99	0.15
BS-453	12	12 1/2	1/4	11.975	0.060	0.275	0.006	304.17	1.52	6.99	0.15
BS-454	12 1/2	13	1/4	12.475	0.060	0.275	0.006	316.87	1.52	6.99	0.15
BS-455	13	13 1/2	1/4	12.975	0.060	0.275	0.006	329.57	1.52	6.99	0.15
BS-456	13 1/2	14	1/4	13.475	0.070	0.275	0.006	342.27	1.78	6.99	0.15
BS-457	14	14 1/2	1/4	13.975	0.070	0.275	0.006	354.97	1.78	6.99	0.15
BS-458	14 1/2	15	1/4	14.475	0.070	0.275	0.006	367.67	1.78	6.99	0.15
BS-459	15	15 1/2	1/4	14.975	0.070	0.275	0.006	380.37	1.78	6.99	0.15
BS-460	15 1/2	16	1/4	15.475	0.070	0.275	0.006	393.07	1.78	6.99	0.15
BS-461	16	16 1/2	1/4	15.955	0.075	0.275	0.006	405.26	1.91	6.99	0.15
BS-462	16 1/2	17	1/4	16.455	0.075	0.275	0.006	417.96	1.91	6.99	0.15
BS-463	17	17 1/2	1/4	16.955	0.080	0.275	0.006	430.66	2.03	6.99	0.15
BS-464	17 1/2	18	1/4	17.455	0.085	0.275	0.006	443.36	2.16	6.99	0.15
BS-465	18	18 1/2	1/4	17.955	0.085	0.275	0.006	456.06	2.16	6.99	0.15
BS-466	18 1/2	19	1/4	18.455	0.085	0.275	0.006	468.76	2.16	6.99	0.15
BS-467	19	19 1/2	1/4	18.955	0.090	0.275	0.006	481.46	2.29	6.99	0.15
BS-468	19 1/2	20	1/4	19.455	0.090	0.275	0.006	494.16	2.29	6.99	0.15
BS-469	20	20 1/2	1/4	19.955	0.095	0.275	0.006	506.86	2.41	6.99	0.15
BS-470	21	21 1/2	1/4	20.955	0.095	0.275	0.006	532.26	2.41	6.99	0.15
BS-471	22	22 1/2	1/4	21.955	0.100	0.275	0.006	557.66	2.54	6.99	0.15
BS-472	23	23 1/2	1/4	22.940	0.105	0.275	0.006	582.68	2.67	6.99	0.15
BS-473	24	24 1/2	1/4	23.940	0.110	0.275	0.006	608.08	2.79	6.99	0.15
BS-474	25	25 1/2	1/4	24.940	0.115	0.275	0.006	633.48	2.92	6.99	0.15
BS-475	26	26 1/2	1/4	25.940	0.120	0.275	0.006	658.88	3.05	6.99	0.15

Straight Thread Tube Fitting O-Ring Dimensions

O-Ring Reference Number	Straight Thread Tube Fitting O-ring Size					Metric O-Ring Size (mm)			
	Tube OD	ID	+/-	W	+/-	ID	+/-	W	+/-
BS-3-901	3/32	0.185	0.005	0.056	0.003	4.70	0.13	1.42	0.08
BS-3-902	1/8	0.239	0.005	0.064	0.003	6.07	0.13	1.63	0.08
BS-3-903	3/16	0.301	0.005	0.064	0.003	7.65	0.13	1.63	0.08
BS-3-904	1/4	0.351	0.005	0.072	0.003	8.92	0.13	1.93	0.08
BS-3-905	5/16	0.414	0.005	0.072	0.003	10.52	0.13	1.93	0.08
BS-3-906	3/8	0.468	0.005	0.078	0.003	11.89	0.13	1.98	0.08
BS-3-907	7/16	0.53	0.005	0.082	0.003	13.46	0.13	2.08	0.08
BS-3-908	1/2	0.644	0.009	0.087	0.003	16.36	0.23	2.20	0.08
BS-3-909	9/16	0.706	0.009	0.097	0.003	17.93	0.23	2.46	0.08
BS-3-910	5/8	0.755	0.009	0.097	0.003	19.18	0.23	2.46	0.08
BS-3-911	11/16	0.863	0.009	0.116	0.004	21.92	0.23	2.95	0.10
BS-3-912	3/4	0.924	0.009	0.116	0.004	23.47	0.23	2.95	0.10
BS-3-913	13/16	0.986	0.010	0.116	0.004	25.04	0.25	2.95	0.10
BS-3-914	7/8	1.047	0.010	0.116	0.004	26.62	0.25	2.95	0.10
BS-3-916	1	1.171	0.010	0.116	0.004	29.74	0.25	2.95	0.10
BS-3-918	1 1/8	1.355	0.012	0.116	0.004	34.42	0.30	2.95	0.10
BS-3-920	1 1/4	1.475	0.014	0.118	0.004	37.47	0.36	3.00	0.10
BS-3-924	1 1/2	1.72	0.014	0.118	0.004	43.69	0.36	3.00	0.10
BS-3-928	1 3/4	2.09	0.018	0.118	0.004	53.09	0.46	3.00	0.10
BS-3-932	2	2.337	0.018	0.118	0.004	59.36	0.46	3.00	0.10

Non-Standard O-Ring Dimensions

O-Ring Reference Number	Inside Dia (mm)	Cross Section (mm)	O-Ring Reference Number	Inside Dia (mm)	Cross Section (mm)	O-Ring Reference Number	Inside Dia (mm)	Cross Section (mm)
BS 606	1.78	1.02	BS 824	39.69	3.53	BS 360A	149.23	5.34
BS 607	2.54	1.02	BS 825	41.28	3.53	BS 870	149.23	5.34
BS 801	3.17	1.78	BS 826	42.86	3.53	BS 361A	155.00	5.34
BS 802	4.76	1.78	BS 827	44.45	3.53	BS 644	155.00	5.34
BS 803	6.35	1.78	BS 828	46.04	3.53	BS 362A	161.30	5.34
BS 610	6.75	1.78	BS 829	47.63	3.53	BS 645	161.30	5.34
BS 804	7.94	1.78	BS 830	49.21	3.53	BS 363A	167.70	5.34
BS 611	8.73	1.78	BS 831	50.80	3.53	BS 646	167.70	5.34
BS 806	11.11	1.78	BS 832	52.39	3.53	BS 624	114.70	6.99
BS 517	36.27	1.78	BS 833	53.98	3.53	BS 647	174.00	6.99
BS 519	39.45	1.78	BS 834	55.56	3.53	BS 625	124.60	6.99
BS 532	79.00	1.78	BS 835	57.15	3.53	BS 626	134.50	6.99
BS 534	85.34	1.78	BS 836	58.74	3.53	BS 872	155.60	6.99
BS 536	91.70	1.78	BS 837	60.33	3.53	BS 627	159.50	6.99
BS 538	98.05	1.78	BS 838	61.90	3.53	BS 874	161.90	6.99
BS 540	104.40	1.78	BS 839	63.50	3.53	BS 628	166.70	6.99
BS 542	110.74	1.78	BS 840	65.10	3.53	BS 876	168.30	6.99
BS 544	117.10	1.78	BS 841	66.67	3.53	BS 878	174.60	6.99
BS 546	123.44	1.78	BS 842	68.26	3.53	BS 441A	181.00	6.99
BS 548	129.40	1.78	BS 843	69.85	3.53	BS 880	181.00	6.99
BS 550	135.76	1.78	BS 844	71.44	3.53	BS 442A	187.30	6.99
BS 551	138.94	1.78	BS 845	73.02	3.53	BS 882	187.30	6.99
BS 552	142.11	1.78	BS 846	74.60	3.53	BS 443A	193.70	6.99
BS 553	145.29	1.78	BS 619	74.63	5.34	BS 884	193.70	6.99
BS 554	148.46	1.78	BS 620	79.77	5.34	BS 444A	200.00	6.99
BS 555	151.64	1.78	BS 621	89.69	5.34	BS 886	200.00	6.99
BS 556	154.81	1.78	BS 622	100.00	5.34	BS 445A	208.92	6.99
BS 557	158.00	1.78	BS 623	109.54	5.34	BS 674	208.92	6.99
BS 558	161.16	1.78	BS 350A	117.48	5.34	BS 446A	221.62	6.99
BS 559	164.34	1.78	BS 860	117.48	5.34	BS 676	221.62	6.99
BS 560	167.51	1.78	BS 351A	120.70	5.34	BS 447A	234.32	6.99
BS 561	170.69	1.78	BS 861	120.70	5.34	BS 678	234.32	6.99
BS 562	173.87	1.78	BS 352A	123.83	5.34	BS 448A	247.00	6.99
BS 613	9.92	2.62	BS 862	123.83	5.34	BS 680	247.00	6.99
BS 614	11.91	2.62	BS 353A	127.00	5.34	BS 449A	259.70	6.99
BS 807	12.70	2.62	BS 863	127.00	5.34	BS 682	259.70	6.99
BS 615	13.10	2.62	BS 354A	130.18	5.34	BS 450A	272.40	6.99
BS 616	15.08	2.62	BS 864	130.18	5.34	BS 684	272.40	6.99
BS 809	15.88	2.62	BS 355A	133.35	5.34	BS 451A	285.10	6.99
BS 810	17.46	2.62	BS 865	133.35	5.34	BS 686	285.10	6.99
BS 617	17.86	2.62	BS 356A	136.53	5.34	BS 452A	297.80	6.99
BS 812	20.63	2.62	BS 866	136.53	5.34	BS 688	297.47	6.99
BS 813	22.22	2.62	BS 357A	139.70	5.34	BS 453A	310.50	6.99
BS 814	23.81	2.62	BS 867	139.70	5.34	BS 648	310.50	6.99
BS 641	77.50	2.62	BS 358A	142.88	5.34	BS 649	323.20	6.99
BS 642	80.60	2.62	BS 868	142.88	5.34	BS 650	335.90	6.99
BS 643	83.80	2.62	BS 359A	146.05	5.34			
BS 618	25.80	3.53	BS 869	146.05	5.34			

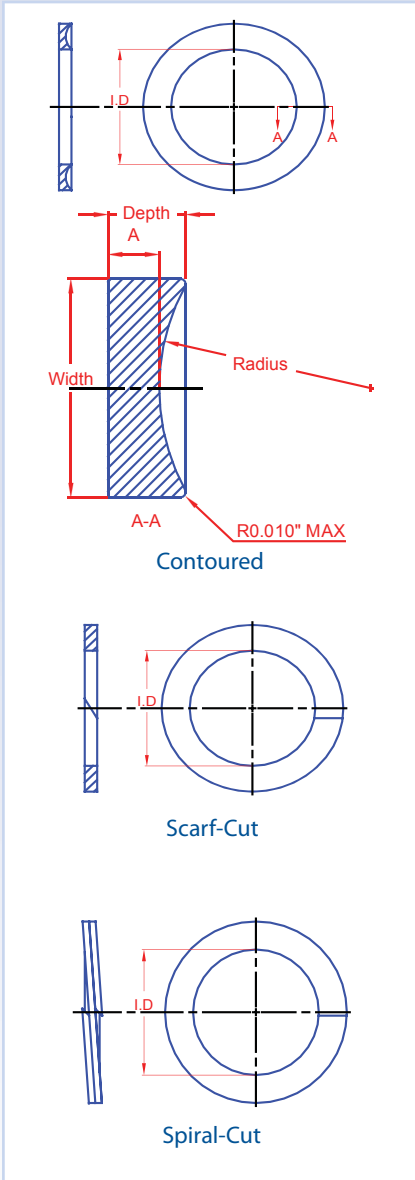

Introduction

Back-Up Rings are a polymer or rubber ring used to prevent the O-Ring from entering the extrusion gap. In high pressure applications the soft rubber O-Ring material can be forced into the extrusion gap which can cause the O-Ring to fail. The harder Back-Up Ring material will prevent the O-Ring from extruding and help prevent premature degradation.

Contoured Back-up Rings

Contoured Back-Up Rings are predominately manufactured from moulded 90° Durometer Nitrile or Viton with a contour on one face where contact is made with the O-Ring.

Back-Up Rings are specifically designed to be used in conjunction with an O-Ring to prevent extrusion of the O-Ring in machined grooves. They can be used on either one or on both sides of the O-Ring for bidirectional pressure. Both options are simple to install.

We would recommend the use of Contoured Back-Up Rings when the hydraulic pressure exceeds 100bar. Additional benefits of Back-Up Rings are broader allowable machining tolerances and also provide improved clearance of mating parts.

We stock all standard Nitrile 90° Durometer Contoured Back-Up Rings, along with the most commonly used sizes in Viton rubber.

All parts are supplied with batch numbers and cure dates.

All sizes correspond to the BS & AS568 O-Rings sizes with which they are used.

Availability

Contoured Back-Up Rings are manufactured from 90° Durometer Nitrile, but also Viton is available in many sizes.

Scarf-Cut, Spiral-Cut and Butt-Cut Back-Up Rings are only available in PTFE. These styles of back-up rings aid installation. We also supply solid flat back-up rings.

CONTOURED BACK-UP RING REFERENCE GUIDE

Ref	I.D.	Width	Radius	A.	Depth, D	Ref	I.D.	Width	Radius	A.	Depth, D
CB-004	0.096	0.053	0.087	0.045	0.049	CB-115	0.702	0.086	0.129	0.045	0.053
CB-005	0.127	0.053	0.087	0.045	0.049	CB-116	0.765	0.086	0.129	0.045	0.053
CB-006	0.140	0.053	0.087	0.045	0.049	CB-117	0.831	0.086	0.129	0.045	0.053
CB-007	0.171	0.053	0.087	0.045	0.049	CB-118	0.893	0.086	0.129	0.045	0.053
CB-008	0.202	0.053	0.087	0.045	0.049	CB-119	0.956	0.086	0.129	0.045	0.053
CB-009	0.234	0.053	0.087	0.045	0.049	CB-120	1.018	0.086	0.129	0.045	0.053
CB-010	0.265	0.053	0.087	0.045	0.049	CB-121	1.081	0.086	0.129	0.045	0.053
CB-011	0.327	0.053	0.087	0.045	0.049	CB-122	1.143	0.086	0.129	0.045	0.053
CB-012	0.390	0.053	0.087	0.045	0.049	CB-123	1.206	0.086	0.129	0.045	0.053
CB-013	0.455	0.053	0.087	0.045	0.049	CB-124	1.268	0.086	0.129	0.045	0.053
CB-014	0.518	0.053	0.087	0.045	0.049	CB-125	1.331	0.086	0.129	0.045	0.053
CB-015	0.580	0.053	0.087	0.045	0.049	CB-126	1.393	0.086	0.129	0.045	0.053
CB-016	0.643	0.053	0.087	0.045	0.049	CB-127	1.456	0.086	0.129	0.045	0.053
CB-017	0.705	0.053	0.087	0.045	0.049	CB-128	1.518	0.086	0.129	0.045	0.053
CB-018	0.768	0.053	0.087	0.045	0.049	CB-129	1.581	0.086	0.129	0.045	0.053
CB-019	0.893	0.053	0.087	0.045	0.049	CB-130	1.643	0.086	0.129	0.045	0.053
CB-020	0.893	0.053	0.087	0.045	0.049	CB-131	1.706	0.086	0.129	0.045	0.053
CB-021	0.955	0.053	0.087	0.045	0.049	CB-132	1.768	0.086	0.129	0.045	0.053
CB-022	1.018	0.053	0.087	0.045	0.049	CB-133	1.831	0.086	0.129	0.045	0.053
CB-023	1.080	0.053	0.087	0.045	0.049	CB-134	1.893	0.086	0.129	0.045	0.053
CB-024	1.143	0.053	0.087	0.045	0.049	CB-135	1.956	0.086	0.129	0.045	0.053
CB-025	1.205	0.053	0.087	0.045	0.049	CB-136	2.018	0.086	0.129	0.045	0.053
CB-026	1.268	0.053	0.087	0.045	0.049	CB-137	2.081	0.086	0.129	0.045	0.053
CB-027	1.330	0.053	0.087	0.045	0.049	CB-138	2.143	0.086	0.129	0.045	0.053
CB-028	1.393	0.053	0.087	0.045	0.049	CB-139	2.206	0.086	0.129	0.045	0.053
CB-029	1.518	0.053	0.087	0.045	0.049	CB-140	2.268	0.086	0.129	0.045	0.053
CB-030	1.643	0.053	0.087	0.045	0.049	CB-141	2.331	0.086	0.129	0.045	0.053
CB-031	1.768	0.053	0.087	0.045	0.049	CB-142	2.393	0.086	0.129	0.045	0.053
CB-032	1.893	0.053	0.087	0.045	0.049	CB-143	2.456	0.086	0.129	0.045	0.053
CB-033	2.018	0.053	0.087	0.045	0.049	CB-144	2.528	0.086	0.129	0.045	0.053
CB-034	2.143	0.053	0.087	0.045	0.049	CB-150	2.893	0.086	0.129	0.045	0.053
CB-035	2.268	0.053	0.087	0.045	0.049	CB-151	3.018	0.086	0.129	0.045	0.053
CB-036	2.393	0.053	0.087	0.045	0.049	CB-152	3.268	0.086	0.129	0.045	0.053
CB-037	2.519	0.053	0.087	0.045	0.049	CB-153	3.518	0.086	0.129	0.045	0.053
CB-038	2.643	0.053	0.087	0.045	0.049	CB-154	3.768	0.086	0.129	0.045	0.053
CB-039	2.768	0.053	0.087	0.045	0.049	CB-155	4.018	0.086	0.129	0.045	0.053
CB-040	2.893	0.053	0.087	0.045	0.049	CB-156	4.268	0.086	0.129	0.045	0.053
CB-041	3.018	0.053	0.087	0.045	0.049	CB-157	4.518	0.086	0.129	0.045	0.053
CB-042	3.518	0.053	0.087	0.045	0.049	CB-158	4.768	0.086	0.129	0.045	0.053
CB-043	3.518	0.053	0.087	0.045	0.049	CB-159	5.018	0.086	0.129	0.045	0.053
CB-044	3.768	0.053	0.087	0.045	0.049	CB-160	5.268	0.086	0.129	0.045	0.053
CB-045	4.018	0.053	0.087	0.045	0.049	CB-161	5.518	0.086	0.129	0.045	0.053
CB-046	4.268	0.053	0.087	0.045	0.049	CB-162	5.768	0.086	0.129	0.045	0.053
CB-047	4.518	0.053	0.087	0.045	0.049	CB-163	6.018	0.086	0.129	0.045	0.053
CB-048	4.768	0.053	0.087	0.045	0.049	CB-164	6.268	0.086	0.129	0.045	0.053
CB-049	5.018	0.053	0.087	0.045	0.049	CB-165	6.518	0.086	0.129	0.045	0.053
CB-050	5.268	0.053	0.087	0.045	0.049	CB-166	6.768	0.086	0.129	0.045	0.053
CB-102	0.077	0.086	0.129	0.045	0.053	CB-167	7.018	0.086	0.129	0.045	0.053
CB-103	0.109	0.086	0.129	0.045	0.053	CB-168	7.268	0.086	0.129	0.045	0.053
CB-104	0.140	0.086	0.129	0.045	0.053	CB-169	7.518	0.086	0.129	0.045	0.053
CB-105	0.171	0.086	0.129	0.045	0.053	CB-170	7.768	0.086	0.129	0.045	0.053
CB-106	0.202	0.086	0.129	0.045	0.053	CB-171	8.018	0.086	0.129	0.045	0.053
CB-107	0.234	0.086	0.129	0.045	0.053	CB-172	8.268	0.086	0.129	0.045	0.053
CB-108	0.265	0.086	0.129	0.045	0.053	CB-173	8.518	0.086	0.129	0.045	0.053
CB-109	0.327	0.086	0.129	0.045	0.053	CB-174	8.768	0.086	0.129	0.045	0.053
CB-110	0.390	0.086	0.129	0.045	0.053	CB-175	9.018	0.086	0.129	0.045	0.053
CB-111	0.452	0.086	0.129	0.045	0.053	CB-176	9.268	0.086	0.129	0.045	0.053
CB-112	0.515	0.086	0.129	0.045	0.053	CB-177	9.518	0.086	0.129	0.045	0.053
CB-113	0.577	0.086	0.129	0.045	0.053	CB-178	9.768	0.086	0.129	0.045	0.053
CB-114	0.640	0.086	0.129	0.045	0.053	CB-201	0.202	0.118	0.174	0.040	0.050

All dimensions in inches



Telephone : 01274 - 688222
 Fax : 01274 - 688549
 E-mail : enquiries@klingeruk.co.uk

Klinger Acorn

CONTOURED BACK-UP RING REFERENCE GUIDE

Ref	I.D.	Width	Radius	A.	Depth, D	Ref	I.D.	Width	Radius	A.	Depth, D
CB-202	0.265	0.118	0.174	0.040	0.050	CB-262	7.018	0.118	0.174	0.040	0.050
CB-203	0.327	0.118	0.174	0.040	0.050	CB-263	7.268	0.118	0.174	0.040	0.050
CB-204	0.390	0.118	0.174	0.040	0.050	CB-264	7.518	0.118	0.174	0.040	0.050
CB-205	0.455	0.118	0.174	0.040	0.050	CB-265	7.768	0.118	0.174	0.040	0.050
CB-206	0.518	0.118	0.174	0.040	0.050	CB-266	8.018	0.118	0.174	0.040	0.050
CB-207	0.580	0.118	0.174	0.040	0.050	CB-267	8.268	0.118	0.174	0.040	0.050
CB-208	0.643	0.118	0.174	0.040	0.050	CB-268	8.518	0.118	0.174	0.040	0.050
CB-209	0.705	0.118	0.174	0.040	0.050	CB-269	8.768	0.118	0.174	0.040	0.050
CB-210	0.765	0.118	0.174	0.040	0.050	CB-270	9.018	0.118	0.174	0.040	0.050
CB-211	0.828	0.118	0.174	0.040	0.050	CB-271	9.268	0.118	0.174	0.040	0.050
CB-212	0.891	0.118	0.174	0.040	0.050	CB-272	9.518	0.118	0.174	0.040	0.050
CB-213	0.953	0.118	0.174	0.040	0.050	CB-273	9.768	0.118	0.174	0.040	0.050
CB-214	1.016	0.118	0.174	0.040	0.050	CB-274	10.018	0.118	0.174	0.040	0.050
CB-215	1.078	0.118	0.174	0.040	0.050	CB-275	10.518	0.118	0.174	0.040	0.050
CB-216	1.141	0.118	0.174	0.040	0.050	CB-276	11.018	0.118	0.174	0.040	0.050
CB-217	1.203	0.118	0.174	0.040	0.050	CB-277	11.518	0.118	0.174	0.040	0.050
CB-218	1.266	0.118	0.174	0.040	0.050	CB-278	12.018	0.118	0.174	0.040	0.050
CB-219	1.334	0.118	0.174	0.040	0.050	CB-279	13.018	0.118	0.174	0.040	0.050
CB-220	1.397	0.118	0.174	0.040	0.050	CB-280	14.018	0.118	0.174	0.040	0.050
CB-221	1.459	0.118	0.174	0.040	0.050	CB-281	15.018	0.118	0.174	0.040	0.050
CB-222	1.522	0.118	0.174	0.040	0.050	CB-282	15.989	0.118	0.174	0.040	0.050
CB-223	1.647	0.118	0.174	0.040	0.050	CB-283	16.989	0.118	0.174	0.040	0.050
CB-224	1.772	0.118	0.174	0.040	0.050	CB-284	17.989	0.118	0.174	0.040	0.050
CB-225	1.897	0.118	0.174	0.040	0.050	CB-309	0.450	0.183	0.262	0.060	0.076
CB-226	2.022	0.118	0.174	0.040	0.050	CB-310	0.513	0.183	0.262	0.060	0.076
CB-227	2.147	0.118	0.174	0.040	0.050	CB-311	0.575	0.183	0.262	0.060	0.076
CB-228	2.272	0.118	0.174	0.040	0.050	CB-312	0.638	0.183	0.262	0.060	0.076
CB-229	2.397	0.118	0.174	0.040	0.050	CB-313	0.700	0.183	0.262	0.060	0.076
CB-230	2.522	0.118	0.174	0.040	0.050	CB-314	0.763	0.183	0.262	0.060	0.076
CB-231	2.631	0.118	0.174	0.040	0.050	CB-315	0.825	0.183	0.262	0.060	0.076
CB-232	2.756	0.118	0.174	0.040	0.050	CB-316	0.888	0.183	0.262	0.060	0.076
CB-233	2.881	0.118	0.174	0.040	0.050	CB-317	0.950	0.183	0.262	0.060	0.076
CB-234	3.006	0.118	0.174	0.040	0.050	CB-318	1.103	0.183	0.262	0.060	0.076
CB-235	3.131	0.118	0.174	0.040	0.050	CB-319	1.075	0.183	0.262	0.060	0.076
CB-236	3.256	0.118	0.174	0.040	0.050	CB-320	1.138	0.183	0.262	0.060	0.076
CB-237	3.381	0.118	0.174	0.040	0.050	CB-321	1.200	0.183	0.262	0.060	0.076
CB-238	3.506	0.118	0.174	0.040	0.050	CB-322	1.263	0.183	0.262	0.060	0.076
CB-239	3.631	0.118	0.174	0.040	0.050	CB-323	1.316	0.183	0.262	0.060	0.076
CB-240	3.756	0.118	0.174	0.040	0.050	CB-324	1.388	0.183	0.262	0.060	0.076
CB-241	3.881	0.118	0.174	0.040	0.050	CB-325	1.513	0.183	0.262	0.060	0.076
CB-242	4.006	0.118	0.174	0.040	0.050	CB-326	1.638	0.183	0.262	0.060	0.076
CB-243	4.131	0.118	0.174	0.040	0.050	CB-327	1.763	0.183	0.262	0.060	0.076
CB-244	4.256	0.118	0.174	0.040	0.050	CB-328	1.888	0.183	0.262	0.060	0.076
CB-245	4.381	0.118	0.174	0.040	0.050	CB-329	2.013	0.183	0.262	0.060	0.076
CB-246	4.506	0.118	0.174	0.040	0.050	CB-330	2.138	0.183	0.262	0.060	0.076
CB-247	4.631	0.118	0.174	0.040	0.050	CB-331	2.268	0.183	0.262	0.060	0.076
CB-248	4.768	0.118	0.174	0.040	0.050	CB-332	2.393	0.183	0.262	0.060	0.076
CB-249	4.893	0.118	0.174	0.040	0.050	CB-333	2.518	0.183	0.262	0.060	0.076
CB-250	5.018	0.118	0.174	0.040	0.050	CB-334	2.643	0.183	0.262	0.060	0.076
CB-251	5.143	0.118	0.174	0.040	0.050	CB-335	2.768	0.183	0.262	0.060	0.076
CB-252	5.268	0.118	0.174	0.040	0.050	CB-336	2.893	0.183	0.262	0.060	0.076
CB-253	5.393	0.118	0.174	0.040	0.050	CB-337	3.018	0.183	0.262	0.060	0.076
CB-254	5.518	0.118	0.174	0.040	0.050	CB-338	3.143	0.183	0.262	0.060	0.076
CB-255	5.643	0.118	0.174	0.040	0.050	CB-339	3.273	0.183	0.262	0.060	0.076
CB-256	5.768	0.118	0.174	0.040	0.050	CB-340	3.398	0.183	0.262	0.060	0.076
CB-257	5.893	0.118	0.174	0.040	0.050	CB-341	3.523	0.183	0.262	0.060	0.076
CB-258	6.018	0.118	0.174	0.040	0.050	CB-342	3.648	0.183	0.262	0.060	0.076
CB-259	6.268	0.118	0.174	0.040	0.050	CB-343	3.773	0.183	0.262	0.060	0.076
CB-260	6.518	0.118	0.174	0.040	0.050	CB-344	3.898	0.183	0.262	0.060	0.076
CB-261	6.768	0.118	0.174	0.040	0.050	CB-345	4.028	0.183	0.262	0.060	0.076

All dimensions in inches

CONTOURED BACK-UP RING REFERENCE GUIDE

Ref	I.D.	Width	Radius	A.	Depth, D	Ref	I.D.	Width	Radius	A.	Depth, D
CB-346	4.153	0.183	0.262	0.060	0.076	CB-435	5.801	0.236	0.344	0.096	0.117
CB-347	4.278	0.183	0.262	0.060	0.076	CB-436	5.926	0.236	0.344	0.096	0.117
CB-348	4.403	0.183	0.262	0.060	0.076	CB-437	6.051	0.236	0.344	0.096	0.117
CB-349	4.528	0.183	0.262	0.060	0.076	CB-438	6.274	0.236	0.344	0.096	0.117
CB-350	4.653	0.183	0.262	0.060	0.076	CB-439	6.525	0.236	0.344	0.096	0.117
CB-351	4.778	0.183	0.262	0.060	0.076	CB-440	6.774	0.236	0.344	0.096	0.117
CB-352	4.903	0.183	0.262	0.060	0.076	CB-441	7.024	0.236	0.344	0.096	0.117
CB-353	5.028	0.183	0.262	0.060	0.076	CB-442	7.274	0.236	0.344	0.096	0.117
CB-354	5.153	0.183	0.262	0.060	0.076	CB-443	7.524	0.236	0.344	0.096	0.117
CB-355	5.278	0.183	0.262	0.060	0.076	CB-444	7.774	0.236	0.344	0.096	0.117
CB-356	5.403	0.183	0.262	0.060	0.076	CB-445	8.024	0.236	0.344	0.096	0.117
CB-357	5.528	0.183	0.262	0.060	0.076	CB-446	8.524	0.236	0.344	0.096	0.117
CB-358	5.653	0.183	0.262	0.060	0.076	CB-447	9.024	0.236	0.344	0.096	0.117
CB-359	5.778	0.183	0.262	0.060	0.076	CB-448	9.524	0.236	0.344	0.096	0.117
CB-360	5.903	0.183	0.262	0.060	0.076	CB-449	10.024	0.236	0.344	0.096	0.117
CB-361	6.028	0.183	0.262	0.060	0.076	CB-450	10.524	0.236	0.236	0.096	0.117
CB-362	6.278	0.183	0.262	0.060	0.076	CB-451	11.024	0.236	0.236	0.096	0.117
CB-363	6.528	0.183	0.262	0.060	0.076	CB-452	11.524	0.236	0.236	0.096	0.117
CB-364	6.778	0.183	0.262	0.060	0.076	CB-453	12.024	0.236	0.236	0.096	0.117
CB-365	7.028	0.183	0.262	0.060	0.076	CB-454	12.524	0.236	0.236	0.096	0.117
CB-366	7.278	0.183	0.262	0.060	0.076	CB-455	13.024	0.236	0.236	0.096	0.117
CB-367	7.528	0.183	0.262	0.060	0.076	CB-456	13.524	0.236	0.236	0.096	0.117
CB-368	7.778	0.183	0.262	0.060	0.076	CB-457	14.024	0.236	0.236	0.096	0.117
CB-369	8.028	0.183	0.262	0.060	0.076	CB-458	14.524	0.236	0.236	0.096	0.117
CB-370	8.278	0.183	0.262	0.060	0.076	CB-459	15.024	0.236	0.236	0.096	0.117
CB-371	8.528	0.183	0.262	0.060	0.076	CB-460	15.524	0.236	0.236	0.096	0.117
CB-372	8.778	0.183	0.262	0.060	0.076	CB-461	16.004	0.236	0.236	0.096	0.117
CB-373	9.028	0.183	0.262	0.060	0.076	CB-462	16.504	0.236	0.236	0.096	0.117
CB-374	9.278	0.183	0.262	0.060	0.076	CB-463	17.004	0.236	0.236	0.096	0.117
CB-375	9.528	0.183	0.262	0.060	0.076	CB-464	17.504	0.236	0.236	0.096	0.117
CB-376	9.778	0.183	0.262	0.060	0.076	CB-465	18.004	0.236	0.236	0.096	0.117
CB-377	10.028	0.183	0.262	0.060	0.076	CB-466	18.504	0.236	0.236	0.096	0.117
CB-378	10.528	0.183	0.262	0.060	0.076	CB-467	19.004	0.236	0.236	0.096	0.117
CB-379	11.028	0.183	0.262	0.060	0.076	CB-468	19.504	0.236	0.236	0.096	0.117
CB-380	11.528	0.183	0.262	0.060	0.076	CB-469	20.004	0.236	0.236	0.096	0.117
CB-381	12.028	0.183	0.262	0.060	0.076	CB-470	21.004	0.236	0.236	0.096	0.117
CB-382	13.028	0.183	0.262	0.060	0.076	CB-471	22.004	0.236	0.236	0.096	0.117
CB-383	14.028	0.183	0.262	0.060	0.076	CB-472	23.004	0.236	0.236	0.096	0.117
CB-384	15.028	0.183	0.262	0.060	0.076	CB-473	24.004	0.236	0.236	0.096	0.117
CB-385	16.008	0.183	0.262	0.060	0.076	CB-474	25.004	0.236	0.236	0.096	0.117
CB-386	17.008	0.183	0.262	0.060	0.076	CB-475	26.004	0.236	0.236	0.096	0.117
CB-387	18.008	0.183	0.262	0.060	0.076						
CB-388	19.006	0.183	0.262	0.060	0.076						
CB-389	20.006	0.183	0.262	0.060	0.076						
CB-390	21.006	0.183	0.262	0.060	0.076						
CB-391	22.006	0.183	0.262	0.060	0.076						
CB-392	22.993	0.183	0.262	0.060	0.076						
CB-393	23.993	0.183	0.262	0.060	0.076						
CB-394	24.930	0.183	0.262	0.060	0.076						
CB-395	25.993	0.183	0.262	0.060	0.076						
CB-425	4.551	0.236	0.344	0.096	0.117						
CB-426	4.676	0.236	0.344	0.096	0.117						
CB-427	4.801	0.236	0.344	0.096	0.117						
CB-428	4.926	0.236	0.344	0.096	0.117						
CB-429	5.051	0.236	0.344	0.096	0.117						
CB-430	5.176	0.236	0.344	0.096	0.117						
CB-431	5.301	0.236	0.344	0.096	0.117						
CB-432	5.426	0.236	0.344	0.096	0.117						
CB-433	5.551	0.236	0.344	0.096	0.117						
CB-434	5.676	0.236	0.344	0.096	0.117						

All dimensions in inches



Telephone : 01274 - 688222
 Fax : 01274 - 688549
 E-mail : enquiries@klingeruk.co.uk



Introduction

Geopaks are a multi-purpose seal which combines a Nitrile O-Ring with a conventional lip seal. The addition of the O-Ring on the lip seal makes the Geopak able to seal in vacuum, low pressure and high pressure applications. In low/non-pressure applications lip seals are prone to leaking due to low lip loading, but with the addition of the O-Ring the lip seal is energised exerting a constant force on the sealing edge. In high pressure applications the O-Ring reduces the prospect of the lip seal deforming due to the internal pressure.

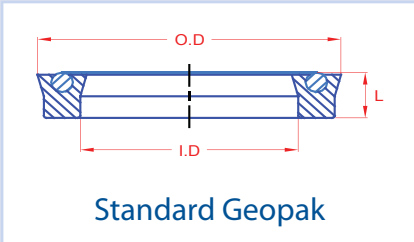

Standard Geopak

Nitrile O-Ring Energised Geopaks are an ideal solution for rod and piston applications. This is due to its square section and its ability to retrofit into existing O-Ring Grooves.

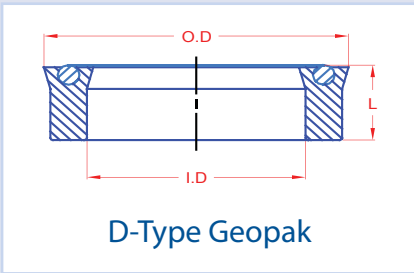

D-Type Geopak

D-Type Geopak has similar characteristics to a B-Type but with improved sealing stability for heavy duty applications.

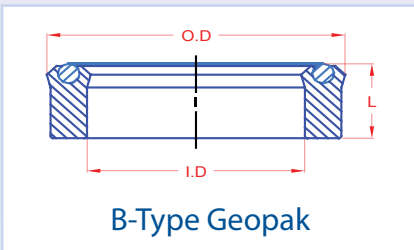

B-Type Geopak

B-Type Geopak's rectangular, long body and back bevel seal lip increases squeeze and improves sealing.

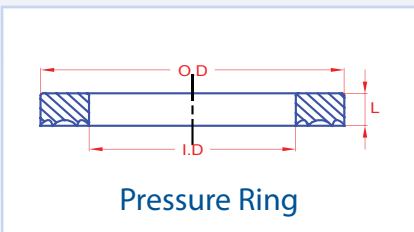

Pressure Ring

Pressure Rings are used in conjunction with B-Type Geopaks. This polyurethane Pressure Ring converts a Geopak ring from a single acting seal to a bidirectional seal. The "L" dimension is the additional groove length required to install both the pressure ring and Geopak.

Part Number	I.D.	O.D.	L	Part Number	I.D.	O.D.	L	Part Number	I.D.	O.D.	L
1250-0062	1/16	5/16	1/8	1250-0937	15/16	1 3/16	1/8	2500-1375-375B	1 3/8	1 7/8	3/8
1250-0125-250B	1/8	3/8	1/4	1870-0937	15/16	1 5/16	3/16	3120-1375	1 3/8	2	5/16
1250-1750	1/8	2	1/4	1870-0937-312B	15/16	1 5/16	5/16	3120-1375-500B	1 3/8	2	1/2
1250-0187-250B	3/16	7/16	1/4	2500-0937	15/16	1 7/16	1/4	3120-1375-500D	1 3/8	2	1/2
1250-0250	1/4	1/2	1/8	1250-1000	1	1 1/4	1/8	3750-1375	1 3/8	2 1/8	3/8
1250-0250-250B	1/4	1/2	1/4	1250-1000-187B	1	1 1/4	3/16	3750-1375-625B	1 3/8	2 1/8	5/8
3120-0250	1/4	7/8	5/16	1250-1000-250B	1	1 1/4	1/4	1250-1500	1 1/2	1 3/4	1/8
1250-0312 250B	5/16	9/16	1/4	1250-1000-250D	1	1 1/4	1/4	1250-1500-250B	1 1/2	1 3/4	1/4
1250-0375	3/8	5/8	1/8	1560-1000	1	1 5/16	5/32	1250-1500-250D	1 1/2	1 3/4	1/4
1250-0375-187B	3/8	5/8	3/16	1870-1000	1	1 3/8	3/16	1870-1500	1 1/2	1 7/8	3/16
1870-0375	3/8	3/4	3/16	1870-1000-312B	1	1 3/8	5/16	1870-1500-187B	1 1/2	1 7/8	3/16
3120-0375	3/8	1	5/16	1870-1000-312D	1	1 3/8	5/16	1870-1500-375B	1 1/2	1 7/8	3/8
1870-0437	7/16	13/16	3/16	2500-1000	1	1 1/2	1/4	2500-1500	1 1/2	2	1/4
1250-0500	1/2	3/4	1/8	2500-1000-375B	1	1 1/2	3/8	2500-1500-250B	1 1/2	2	1/4
1250-0500-125B	1/2	3/4	1/8	3120-1000-500B	1	1 5/8	1/2	2500-1500-375B	1 1/2	2	3/8
1250-0500-250B	1/2	3/4	1/4	3120-1000-500D	1	1 5/8	1/2	2500-1500-375D	1 1/2	2	3/8
1250-0500-250D	1/2	3/4	1/4	5000-1000	1	2	1/2	3120-1500	1 1/2	2 1/8	5/16
1870-0500	1/2	7/8	3/16	1250-1062-250B	1 1/16	1 5/16	1/4	3120-1500-500B	1 1/2	2 1/8	1/2
1870-0500-312B	1/2	7/8	5/16	1250-1125	1 1/8	1 3/8	1/8	3120-1500-500D	1 1/2	2 1/8	1/2
2500-0500-375B	1/2	1	3/8	1250-1125-250B	1 1/8	1 3/8	1/4	3750-1500	1 1/2	2 1/4	3/8
2500-0500	1/2	1	1/4	1870-1125	1 1/8	1 1/2	3/16	3750-1500-625B	1 1/2	2 1/4	5/8
2500-0500-375D	1/2	1	3/8	1870-1125-312B	1 1/8	1 1/2	5/16	5000-1500	1 1/2	2 1/2	1/2
3750-0500	1/2	1 1/4	3/8	2500-1125	1 1/8	1 5/8	1/4	1870-1625	1 5/8	2	3/16
1870-0562	9/16	15/16	3/16	2500-1125-375B	1 1/8	1 5/8	3/8	1870-1625-250D	1 5/8	2	1/4
1250-0625	5/8	7/8	1/8	1250-1187	1 3/16	1 7/16	1/8	1870-1625-312B	1 5/8	2	5/16
1250-0625-187B	5/8	7/8	3/16	1250-1187-250B	1 3/16	1 7/16	1/4	1870-1625-375B	1 5/8	2	3/8
1250-0625-250B	5/8	7/8	1/4	1560-1187	1 3/16	1 1/2	5/32	1870-1625-375D	1 5/8	2	3/8
1250-0625-250D	5/8	7/8	1/4	1870-1187	1 3/16	1 9/16	3/16	2500-1625	1 5/8	2 1/8	1/4
1870-0625-312B	5/8	1	5/16	2500-1187	1 3/16	1 11/16	1/4	2500-1625-375B	1 5/8	2 1/8	3/8
1870-0625-312D	5/8	1	5/16	3120-1187	1 3/16	1 13/16	5/16	3120-1625	1 5/8	2 1/4	5/16
2500-0625	5/8	1 1/8	1/4	1250-1250	1 1/4	1 1/2	1/8	3750-1625	1 5/8	2 3/8	3/8
2500-0625-375B	5/8	1 1/8	3/8	1250-1250-187B	1 1/4	1 1/2	3/16	1250-1750-250D	1 3/4	2	1/4
2500-0625-375D	5/8	1 1/8	3/8	1250-1250-250B	1 1/4	1 1/2	1/4	1870-1750	1 3/4	2 1/8	3/16
1250-0687	11/16	15/16	1/8	1870-1250	1 1/4	1 5/8	3/16	1870-1750-230B	1 3/4	2 1/8	0.230
2500-0687	11/16	1 3/16	1/4	1870-1250-250B	1 1/4	1 5/8	1/4	1870-1750-312B	1 3/4	2 1/8	5/16
1250-0750	3/4	1	1/8	1870-1250-312B	1 1/4	1 5/8	5/16	1870-1750-375B	1 3/4	2 1/8	3/8
1250-0750-125B	3/4	1	1/8	1870-1250-312D	1 1/4	1 5/8	5/16	2500-1750	1 3/4	2 1/4	1/4
1250-0750-250B	3/4	1	1/4	1870-1250-375B	1 1/4	1 5/8	3/8	2500-1750-375B	1 3/4	2 1/4	3/8
1250-0750-250D	3/4	1	1/4	2500-1250	1 1/4	1 3/4	1/4	3120-1750	1 3/4	2 3/8	5/16
1870-0750	3/4	1 1/8	3/16	2500-1250-375B	1 1/4	1 3/4	3/8	3120-1750-500B	1 3/4	2 3/8	1/2
1870-0750-312B	3/4	1 1/8	5/16	3120-1250-500B	1 1/4	1 7/8	1/2	3120-1750-500D	1 3/4	2 3/8	1/2
1870-0750-312D	3/4	1 1/8	5/16	3120-1250-500D	1 1/4	1 7/8	1/2	3750-1750	1 3/4	2 1/2	3/8
2500-0750	3/4	1 1/4	1/4	3750-1250	1 1/4	2	3/8	3750-1750-625B	1 3/4	2 1/2	5/8
2500-0750-375B	3/4	1 1/4	3/8	3750-1250-625D	1 1/4	2	5/8	5000-1750-750B	1 3/4	2 3/4	3/4
2500-0750-375D	3/4	1 1/4	3/8	1250-1312	1 5/16	1 9/16	1/8	6250-1750	1 3/4	3	5/8
3120-0750	3/4	1 3/8	5/16	1870-1312	1 5/16	1 11/16	3/16	1250-1875	1 7/8	2 1/8	1/8
3750-0750	3/4	1 1/2	3/8	1870-1312-312B	1 5/16	1 11/16	5/16	1870-1875-375B	1 7/8	2 1/4	3/8
1250-0812	13/16	1 1/16	1/8	3120-1312	1 5/16	1 15/16	5/16	1870-1875-375D	1 7/8	2 1/4	3/8
1250-0812-250B	13/16	1 1/16	1/4	3750-1312	1 5/16	2 1/16	3/8	2500-1875	1 7/8	2 3/8	1/4
1250-0875	7/8	1 1/8	1/8	1250-1375	1 3/8	1 5/8	1/8	2500-1875-375B	1 7/8	2 3/8	3/8
1250-0875-250B	7/8	1 1/8	1/4	1250-1375-250B	1 3/8	1 5/8	1/4	3120-1875	1 7/8	2 1/2	5/16
1870-0875-312B	7/8	1 1/4	5/16	1560-1375	1 3/8	1 11/16	5/32	3120-1875-500B	1 7/8	2 1/2	1/2
1870-0875-375B	7/8	1 1/4	3/8	1870-1375	1 3/8	1 3/4	3 1/6	1250-2000	2	2 1/4	1/8
2500-0875-375B	7/8	1 3/8	3/8	1870-1375-312B	1 3/8	1 3/4	5/16	1250-2000-250D	2	2 1/4	1/4
3120-0875	7/8	1 1/2	5/16	1870-1375-312D	1 3/8	1 3/4	5/16	1870-2000	2	3 3/8	3/16
3750-0875	7/8	1 5/8	3/8	2500-1375	1 3/8	1 7/8	1/4	1870-2000-230B	2	2 3/8	0.230

All dimensions in inches



Telephone : 01274 - 688222
 Fax : 01274 - 688549
 E-mail : enquiries@klingeruk.co.uk

GEOPAK REFERENCE GUIDE

Part Number	I.D.	O.D.	L	Part Number	I.D.	O.D.	L	Part Number	I.D.	O.D.	L
1870-2000-312B	2	2 3/8	5/16	3120-2625-500D	2 5/8	3 1/4	1/2	2500-3500-312B	3 1/2	4	5/16
1870-2000-375B	2	2 3/8	3/8	3750-2625-625B	2 5/8	3 3/8	5/8	2500-3500-375B	3 1/2	4	3/8
1870-2000-375D	2	2 3/8	3/8	1250-2750-250B	2 3/4	3	1/4	2500-3500-375D	3 1/2	4	3/8
2500-2000	2	2 1/2	1/4	1870-2750-187B	2 3/4	3 1/8	3/16	3120-3500-500B	3 1/2	4 1/8	1/2
2500-2000-250B	2	2 1/2	1/4	1870-2750-375B	2 3/4	3 1/8	3/8	3120-3500-500D	3 1/2	4 1/8	1/2
2500-2000-375B	2	2 1/2	3/8	1870-2750-375D	2 3/4	3 1/8	3/8	3750-3500	3 1/2	4 1/4	3/8
2500-2000-375D	2	2 1/2	3/8	2500-2750	2 3/4	3 1/4	1/4	3750-3500-625B	3 1/2	4 1/4	5/8
3120-2000	2	2 5/8	5/16	2500-2750-375B	2 3/4	3 1/4	3/8	3750-3500-625D	3 1/2	4 1/4	5/8
3120-2000-500B	2	2 5/8	1/2	2500-2750-375D	2 3/4	3 1/4	3/8	1870-3625	3 5/8	4	3/16
3120-2000-500D	2	2 5/8	1/2	3120-2750	2 3/4	3 3/8	5/16	1870-3625-375B	3 5/8	4	3/8
3750-2000	2	2 3/4	3/8	3120-2750-500B	2 3/4	3 3/8	1/2	1870-3625-375D	3 5/8	4	3/8
3750-2000-625B	2	2 3/4	5/8	3750-2750	2 3/4	3 1/2	3/8	2500-3625	3 5/8	4 1/8	1/4
3750-2000-625D	2	2 3/4	5/8	3750-2750-625B	2 3/4	3 1/2	5/8	2500-3625-375B	3 5/8	4 1/8	3/8
5000-2000-750B	2	3	3/4	6250-2750	2 3/4	4	5/8	3120-3625-500B	3 5/8	4 1/4	1/2
1870-2125	2 1/8	2 1/2	3/16	1870-2875	2 7/8	3 1/4	3/16	3750-3625-625B	3 5/8	4 3/8	5/8
1870-2125-187B	2 1/8	2 1/2	3/16	2500-2875-375B	2 7/8	3 3/8	3/8	1870-3750	3 3/4	4 1/8	3/16
1870-2125-375B	2 1/8	2 1/2	3/8	1250-3000	3	3 1/4	1/8	1870-3750-375B	3 3/4	4 1/8	3/8
2500-2125-375B	2 1/8	2 5/8	3/8	1870-3000	3	3 3/8	3/16	2500-3750	3 3/4	4 1/4	1/4
1870-2250-375B	2 1/4	2 5/8	3/8	1870-3000-375B	3	3 3/8	3/8	2500-3750-375B	3 3/4	4 1/4	3/8
1870-2250-375D	2 1/4	2 5/8	3/8	1870-3000-375D	3	3 3/8	3/8	3120-3750	3 3/4	4 3/8	5/16
2500-2250	2 1/4	2 3/4	1/4	2500-3000	3	3 1/2	1/4	3120-3750-375B	3 3/4	4 3/8	3/8
2500-2250-375B	2 1/4	2 3/4	3/8	2500-3000-375B	3	3 1/2	3/8	3120-3750-625B	3 3/4	4 3/8	5/8
2500-2250-375D	2 1/4	2 3/4	3/8	2500-3000-375D	3	3 1/2	3/8	3750-3750	3 3/4	4 1/2	3/8
3120-2250	2 1/4	2 7/8	5/16	3120-3000-500B	3	3 5/8	1/2	3750-3750-625B	3 3/4	4 1/2	5/8
3120-2250-500B	2 1/4	2 7/8	1/2	3120-3000-562D	3	3 5/8	9/16	5000-3750	3 3/4	4 3/4	1/2
3750-2250-625B	2 1/4	3	5/8	3750-3000	3	3 3/4	3/8	5000-3750-690B	3 3/4	4 3/4	0.690
3750-2250-625D	2 1/4	3	5/8	3750-3000-625B	3	3 3/4	5/8	2500-3875-375D	3 7/8	4 3/8	3/8
1870-2375	2 3/8	2 3/4	3/16	3750-3000-625D	3	3 3/4	5/8	3120-3875-500D	3 7/8	4 1/2	1/2
1870-2375-375B	2 3/8	2 3/4	3/8	5000-3000	3	4	1/2	1870-4000-375B	4	4 3/8	3/8
2500-2375	2 3/8	2 7/8	1/4	5000-3000-750B	3	4	3/4	1870-4000-375B	4	4 3/8	3/8
2500-2375-375B	2 3/8	2 7/8	3/8	1870-3125-187B	3 1/8	3 1/2	3/16	1870-4000-3750D	4	4 3/8	3/8
3120-2375	2 3/8	3	5/16	1870-3125-375B	3 1/8	3 1/2	3/8	2500-4000	4	4 1/2	1/4
3120-2375-500B	2 3/8	3	1/2	3120-3125	3 1/8	3 3/4	5/16	2500-4000-312B	4	4 1/2	5/16
3120-2375-500D	2 3/8	3	1/2	1870-3250	3 1/4	3 5/8	3/16	2500-4000-375B	4	4 1/2	3/8
3750-2375-625B	2 3/8	3 1/8	5/8	2500-3250	3 1/4	3 3/4	1/4	2500-4000-375D	4	4 1/2	3/8
5000-2375	2 3/8	3 3/8	1/2	2500-3250-375B	3 1/4	3 3/4	3/8	2500-4000-562B	4	4 1/2	9/16
1250-2500-250D	2 1/2	2 3/4	1/4	2500-3250-375D	3 1/4	3 3/4	3/8	3120-4000	4	4 5/8	5/16
1870-2500-250B	2 1/2	2 7/8	1/4	3120-3250-500B	3 1/4	3 7/8	1/2	3120-4000-562B	4	4 5/8	9/16
1870-2500-375B	2 1/2	2 7/8	3/8	3120-3250-500D	3 1/4	3 7/8	1/2	3120-4000-562D	4	4 5/8	9/16
1870-2500-375D	2 1/2	2 7/8	3/8	3750-3250	3 1/4	4	3/8	3750-4000-625B	4	4 3/4	5/8
2500-2500	2 1/2	3	1/4	3750-3250-625B	3 1/4	4	5/8	5000-4000	4	5	1/2
2500-2500-375B	2 1/2	3	3/8	3750-3250-625D	3 1/4	4	5/8	1870-4125	4 1/8	4 1/2	3/16
2500-2500-375D	2 1/2	3	3/8	5000-3250-750B	3 1/4	4 1/4	3/4	2500-4125-562B	4 1/8	4 5/8	9/16
3120-2500	2 1/2	3 1/8	5/16	6250-3250	3 1/4	4 1/2	5/8	1870-4250-375B	4 1/4	4 5/8	3/8
3120-2500-500B	2 1/2	3 1/8	1/2	1870-3375	3 3/8	3 3/4	3/16	1870-4250-375D	4 1/4	4 5/8	3/8
3750-2500	2 1/2	3 1/4	5/8	1870-3375-187B	3 3/8	3 3/4	3/16	2500-4250	4 1/4	4 3/4	1/4
3750-2500-625B	2 1/2	3 1/4	5/8	1870-3375-375B	3 3/8	3 3/4	3/8	2500-4250-375B	4 1/4	4 3/4	3/8
3750-2500-625D	2 1/2	3 1/4	5/8	1870-3375-375D	3 3/8	3 3/4	3/8	2500-4250-562B	4 1/4	4 3/4	9/16
5000-2500	2 1/2	3 1/2	1/2	3120-3375	3 3/8	4	5/16	2500-4250-562D	4 1/4	4 3/4	9/16
5000-2500-750B	2 1/2	3 1/2	3/4	3120-3375-500B	3 3/8	4	1/2	3120-4250-562B	4 1/4	4 7/8	9/16
5000-2500-750D	2 1/2	3 1/2	3/4	3120-3375-500D	3 3/8	4	1/2	3120-4250-562D	4 1/4	4 7/8	9/16
1870-2625	2 5/8	3	3/16	3750-3375-625B	3 3/8	4 1/8	5/8	3750-4250	4 1/4	5	3/8
1870-2625-375B	2 5/8	3	3/8	1870-3500	3 1/2	3 7/8	3/16	3750-4250-375B	4 1/4	5	3/8
1870-2625-375D	2 5/8	3	3/8	1870-3500-375B	3 1/2	3 7/8	3/8	3750-4250-625B	4 1/4	5	5/8
2500-2625-375B	2 5/8	3 1/8	3/8	1870-3500-375D	3 1/2	3 7/8	3/8	3750-4250-625D	4 1/4	5	5/8
2500-2625-375D	2 5/8	3 1/8	3/8	2500-3500	3 1/2	4	1/4	5000-4250	4 1/4	5 1/4	1/2

All dimensions in inches

Part Number	I.D.	O.D.	L	Part Number	I.D.	O.D.	L	Part Number	I.D.	O.D.	L
1870-4375-375D	4 3/8	4 3/4	3/8	3750-5500-625B	5 1/2	6 1/4	5/8	3750-7625	7 5/8	8 3/8	3/8
2500-4375	4 3/8	4 7/8	1/4	5000-5500	5 1/2	6 1/2	1/2	3120-7875-625B	7 7/8	8 1/2	5/8
2500-4375-562D	4 3/8	4 7/8	9/16	2500-5750-562B	5 3/4	6 1/4	9/16	2500-8000-562B	8	8 1/2	9/16
3120-4375	4 3/8	5	5/16	2500-5750-562D	5 3/4	6 1/4	9/16	3120-8000	8	8 5/8	5/16
3120-4375-500D	4 3/8	5	1/2	3750-5750	5 3/4	6 1/2	3/8	3750-8000	8	8 3/4	3/8
3120-4375-562D	4 3/8	5	9/16	3750-5750-625B	5 3/4	6 1/2	5/8	3750-8000-500D	8	8 3/4	1/2
2500-4500	4 1/2	5	1/4	3750-5750-625D	5 3/4	6 1/2	5/8	5000-8000	8	9	1/2
2500-4500-312B	4 1/2	5	5/16	5000-5750	5 3/4	6 3/4	1/2	5000-8000-750B	8	9	3/4
2500-4500-375B	4 1/2	5	3/8	3750-5375	5 3/8	6 1/8	3/8	5000-8000-750D	8	9	3/4
2500-4500-375D	4 1/2	5	3/8	3120-5875	5 7/8	6 1/2	5/16	2500-8250-562B	8 1/4	8 3/4	9/16
2500-4500-562B	4 1/2	5	9/16	3750-5875	5 7/8	6 5/8	3/8	3750-8250-625B	8 1/4	9	5/8
3750-4500	4 1/2	5 1/4	3/8	2500-6000	6	6 1/2	1/4	2500-8500-562B	8 1/2	9	9/16
3750-4500-625B	4 1/2	5 1/4	5/8	2500-6000-375B	6	6 1/2	3/8	5000-8500	8 1/2	9 1/2	1/2
5000-4500	4 1/2	5 1/2	1/2	2500-6000-562B	6	6 1/2	9/16	3750-8687	8 11/16	9 7/16	3/8
3750-4625	4 5/8	5 3/8	3/8	2500-6000-562D	6	6 1/2	9/16	2500-8750	8 3/4	9 1/4	1/4
1250-4750	4 3/4	5	1/8	3120-6000	6	6 5/8	5/16	3750-8750	8 3/4	9 1/2	3/8
2500-4750	4 3/4	5 1/4	1/4	3750-6000	6	6 3/4	3/8	3750-8750-625D	8 3/4	9 1/2	5/8
2500-4750-375B	4 3/4	5 1/4	3/8	3750-6000-625B	6	6 3/4	5/8	3750-9000	9	9 3/4	3/8
2500-4750-562B	4 3/4	5 1/4	9/16	5000-6000	6	7	1/2	3750-9000-625B	9	9 3/4	5/8
2500-4750-562D	4 3/4	5 1/4	9/16	5000-6000-750B	6	7	3/4	3750-9000-625D	9	9 3/4	5/8
3120-4750	4 3/4	5 3/8	5/16	3120-6125	6 1/8	6 3/4	5/16	5000-9000	9	10	1/2
3120-4750-625B	4 3/4	5 3/8	5/8	2500-6250-562B	6 1/4	6 3/4	9/16	5000-9000-750B	9	10	3/4
3750-4750	4 3/4	5 1/2	3/8	3120-6250	6 1/4	6 7/8	5/16	5000-9250-750B	9 1/4	10 1/4	3/4
3750-4750-625B	4 3/4	5 1/2	5/8	3750-6250	6 1/4	7	3/8	2500-9750	9 3/4	10 1/4	1/4
3750-4750-625D	4 3/4	5 1/2	5/8	3750-6250-500D	6 1/4	7	1/2	2500-9750-562B	9 3/4	10 1/4	9/16
5000-4750	4 3/4	5 3/4	1/2	3750-6250-625B	6 1/4	7	5/8	3750-9750	9 3/4	10 1/2	3/8
5000-4750-750B	4 3/4	5 3/4	3/4	3120-6375-625D	6 3/8	7	5/8	2501-0000-562B	10	10 1/2	9/16
6250-4750	4 3/4	6	5/8	2500-6500	6 1/2	7	1/4	3750-0000	10	10 3/4	3/8
3120-4875	4 7/8	5 1/2	5/16	2500-6000-375B	6 1/2	7	3/8	5001-0000-750B	10	11	3/4
2500-5000	5	5 1/2	1/4	2500-6500-375D	6 1/2	7	3/8	3751-0500-625B	10 1/2	11 1/4	5/8
2500-5000-375B	5	5 1/2	3/8	2500-6500-562B	6 1/2	7	9/16	5001-1000-750B	11	12	3/4
2500-5000-375D	5	5 1/2	3/8	3120-6500	6 1/2	7 1/8	5/16	3751-1250	11 1/4	12	3/8
2500-5000-562B	5	5 1/2	9/16	3750-6500	6 1/2	7 1/4	3/8	3751-2000	12	12 3/4	3/8
2500-5000-562D	5	5 1/2	9/16	3750-6500-625B	6 1/2	7 1/4	5/8	3750-2250	12 1/4	13	3/8
3120-5000	5	5 5/8	5/16	2500-6750-562D	6 3/4	7 1/4	9/16	2501-2750-562B	12 3/4	13 1/4	9/16
3750-5000-625B	5	5 3/4	5/8	3750-6750-625B	6 3/4	7 1/2	5/8	5001-3500-750B	13 1/2	14 1/2	3/4
5000-5000	5	6	1/2	2500-7000-375B	7	7 1/2	3/8				
5000-5000-750B	5	6	3/4	2500-7000-562B	7	7 1/2	9/16				
2500-5250	5 1/4	5 3/4	1/4	2500-7000-562D	7	7 1/2	9/16				
2500-5250-562D	5 1/4	5 3/4	9/16	3120-7000	7	7 5/8	5/16				
3120-5250	5 1/4	5 7/8	5/16	3750-7000-625B	7	7 3/4	5/8				
3750-5250	5 1/4	6	3/8	3750-7000-625D	7	7 3/4	5/8				
3750-5250-500D	5 1/4	6	1/2	5000-7000	7	8	1/2				
3750-5250-625B	5 1/4	6	5/8	5000-7000-750B	7	8	1/2				
3750-5250-625D	5 1/4	6	5/8	5000-7000-750D	7	8	3/4				
5000-5250-750B	5 1/4	6 1/4	3/4	2500-7250-562B	7 1/4	7 3/4	9/16				
3750-5375	5 3/8	6 1/8	3/8	3120-7250	7 1/4	7 7/8	5/16				
1870-5500-375B	5 1/2	5 7/8	3/8	3750-7250-625D	7 1/4	8	5/8				
2500-5500	5 1/2	6	1/4	3120-7375	7 3/8	8	5/16				
2500-5500-375B	5 1/2	6	3/8	2500-7500	7 1/2	8	1/4				
2500-5500-375D	5 1/2	6	3/8	2500-7500-562B	7 1/2	8	9/16				
2500-5500-562B	5 1/2	6	9/16	2500-7500-562D	7 1/2	8	9/16				
2500-5500-562D	5 1/2	6	9/16	3120-7500	7 1/2	8 1/8	5/16				
3120-5500	5 1/2	6 1/8	5/16	3750-7500-625B	7 1/2	8 1/4	5/8				
3120-5500-375B	5 1/2	6 1/8	3/8	3750-7500-625D	7 1/2	8 1/4	5/8				
3750-5500	5 1/2	6 1/4	3/8	5000-7500	7 1/2	8 1/2	1/2				

All dimensions in inches



Telephone : 01274 - 688222
 Fax : 01274 - 688549
 E-mail : enquiries@klingeruk.co.uk

PISTON SEALS



Introduction

The following Rod and Piston seals are available in a variety of styles to suit a range of sealing applications. Many of the styles can be used in standard O-Ring grooves and depending on the style and arrangement can be used in double-acting applications. They are generally manufactured from Polyurethane and can use a rubber energiser which is often Nitrile or Viton rubber.

G84 Piston Seals

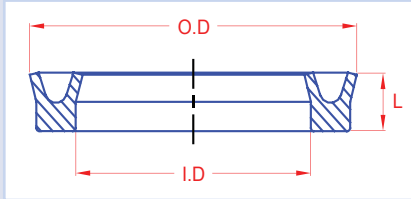

G84 Piston Rod Lip Seal is a square-sectioned nitrile piston rod U-Seal. The seal is designed for low pressure hydraulic and pneumatic applications where an energised sealing edge is not essential.

Part Number	I.D.	O.D.	L.	Part Number	I.D.	O.D.	L.	Part Number	I.D.	O.D.	L.
G84-U-0901209	1/8	5/16	3/32	G84-U-1512515	1 1/4	1 9/16	5/32	G84-U-2128121	2 13/16	3 1/2	7/32
G84-U-0901809	3/16	3/8	3/32	G84-U-1812518	1 1/4	1 5/8	3/16	G84-U-1830018	3	3 3/8	3/16
G84-U-1201812	3/16	7/16	1/8	G84-U-1213712	1 3/8	1 5/8	1/8	G84-U-2130021	3	3 7/16	7/32
G84-U-0902509	1/4	7/16	3/32	G84-U-1513715	1 3/8	1 11/16	5/32	G84-U-2130621	3 1/16	3 1/2	7/32
G84-U-1202512	1/4	1/2	1/8	G84-U-1813718	1 3/8	1 3/4	3/16	G84-U-1832518	3 1/4	3 5/8	3/16
G84-U-1802518	1/4	5/8	3/16	G84-U-2513725	1 3/8	1 7/8	1/4	G84-U-2133121	3 5/16	3 3/4	7/32
G84-U-0903109	5/16	1/2	3/32	G84-U-1215012	1 1/2	1 3/4	1/8	G84-U-1833718	3 3/8	3 3/4	3/16
G84-U-0904309	7/16	5/8	3/32	G84-U-1510155	1 1/2	1 13/16	5/32	G84-U-2527525	3 3/4	3 1/4	1/4
G84-U-0905009	1/2	11/16	3/32	G84-U-1815018	1 1/2	1 7/8	3/16	G84-U-2535025	3 1/2	4	1/4
G84-U-1505015	1/2	13/16	5/32	G84-U-1816218	1 5/8	2	3/16	G84-U-2537525	3 3/4	4 1/4	1/4
G84-U-0905609	9/16	3/4	3/32	G84-U-1217512	1 3/4	2	1/8	G84-U-2540025	4	4 1/2	1/4
G84-U-0906209	5/8	13/16	3/32	G84-U-1817518	1 3/4	2 1/8	3/16	G84-U-3143731	4 3/8	5	7/16
G84-U-1806218	5/8	1	3/16	G84-U-2517525	1 3/4	2 1/4	1/4	G84-U-2844328	4 7/16	5	9/32
G84-U-1203712	3/8	5/8	1/8	G84-U-1510015	1	1 5/16	5/32	G84-U-2540250	4 1/2	5	1/4
G84-U-1204312	7/16	11/16	1/8	G84-U-1810018	1	1 3/8	3/16	G84-U-2845628	4 9/16	5 1/8	9/32
G84-U-1205012	1/2	3/4	1/8	G84-U-1514315	1 7/16	1 3/4	5/32	G84-U-2547525	4 3/4	5 1/4	1/4
G84-U-1205612	9/16	13/16	1/8	G84-U-1818718	1 7/8	2 1/4	3/16	G84-U-2850028	5	5 9/16	9/32
G84-U-1206212	5/8	7/8	1/8	G84-U-1220012	2	2 1/4	1/8	G84-U-3153731	5 3/8	6	5/16
G84-U-1206812	11/16	15/16	1/8	G84-U-1820018	2	2 3/8	3/16	G84-U-2854328	5 7/16	6	9/32
G84-U-1506815	11/16	1	5/32	G84-U-2520025	2	2 1/2	1/4	G84-U-2555025	5 1/2	6	1/4
G84-U-1207512	3/4	1	1/8	G84-U-1821218	2 1/8	2 1/2	3/16	G84-U-2555037	5 1/2	6	3/8
G84-U-1507515	3/4	1 1/16	5/32	G84-U-1823718	2 3/8	2 3/4	3/16	G84-U-3155031	5 1/2	6 1/8	5/16
G84-U-1807518	3/4	1 1/8	3/16	G84-U-1825018	2 1/2	2 7/8	3/16	G84-U-3163731	6 3/8	7	5/16
G84-U-1208112	13/16	1 1/16	1/8	G84-U-2125021	2 1/2	2 15/16	7/32	G84-U-2864328	6 7/16	7	9/32
G84-U-1208712	7/8	1 1/8	1/8	G84-U-2525025	2 1/2	3	1/4	G84-U-3173731	7 3/8	8	5/16
G84-U-1509315	15/16	1 1/4	5/32	G84-U-3725037	2 1/2	3 1/4	3/8	G84-U-5090050	9	10	1/2
G84-U-2509325	15/16	1 7/16	1/4	G84-U-1826218	2 5/8	3	3/16	G84-U-3792537	9 1/4	10	3/8
G84-U-1210012	1	1 1/4	1/8	G84-U-2125621	2 9/16	3	7/32	G84-U-3493134	9 5/16	10	11/32
G84-U-1510615	1 1/16	1 3/8	5/32	G84-U-1828718	2 7/8	3 1/4	3/16	G84-U-40131840	13 3/16	14	13/32
G84-U-1211212	1 1/8	1 3/8	1/8	G84-U-3128731	2 7/8	3 1/2	5/16	G84-U-50110050	11	12	1/2
G84-U-1511815	1 3/16	1 1/2	5/32	G84-U-2127521	2 3/4	3 3/16	7/32	G84-U-37112537	11 1/4	12	3/8
G84-U-1212512	1 1/4	1 1/2	1/8	G84-U-3725737	2 3/4	3 1/2	3/8				

All dimensions in inches

Piston T-Seals

T-Seals are supplied with a back-up ring on both sides of the sealing area, allowing it functions very well in double acting applications. The back-ups are split for ease of installation. Manufactured from Nitrile rubber with Polyurethane backup rings and they are suitable for pressures up to 350bar and a temperature range -40°C to 90°C.

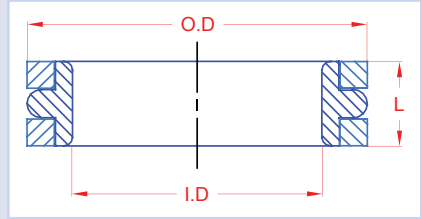

Part Number	I.D.	O.D.	L.	Part Number	I.D.	O.D.	L.	Part Number	I.D.	O.D.	L.
TP-009-208	5/8	7/8	1/8	TP-030-332	2 3/8	2 3/4	3/16	TP-049-427	4 3/4	5 1/4	1/4
TP-011-210	3/4	1	1/8	TP-031-333	2 1/2	2 7/8	3/16	TP-051-429	5	5 1/2	1/4
TP-013-212	7/8	1 1/8	1/8	TP-032-334	2 5/8	3	3/16	TP-053-431	5 1/4	5 3/4	1/4
TP-015-214	1	1 1/4	1/8	TP-033-335	2 3/4	3 1/8	3/16	TP-054-432	5 3/8	5 7/8	1/4
TP-017-216	1 1/8	1 3/8	1/8	TP-034-336	2 7/8	3 1/4	3/16	TP-055-433	5 1/2	6	1/4
TP-018-217	1 3/16	1 7/16	1/8	TP-035-338	3 1/8	3 1/2	3/16	TP-057-435	5 3/4	6 1/4	1/4
TP-019-218	1 1/4	1 1/2	1/8	TP-036-339	3 1/4	3 5/8	3/16	TP-058-437	6	6 1/2	1/4
TP-021-220	1 3/8	1 5/8	1/8	TP-037-340	3 3/8	3 3/4	3/16	TP-060-439	6 1/2	7	1/4
TP-022-222	1 1/2	1 3/4	1/8	TP-038-341	3 1/2	3 7/8	3/16	TP-062-441	7	7 1/2	1/4
TP-023-325	1 1/2	1 7/8	3/16	TP-039-342	3 5/8	4	3/16	TP-064-443	7 1/2	8	1/4
TP-024-326	1 5/8	2	3/16	TP-041-344	3 7/8	4 1/4	3/16	TP-068-447	9	9 1/2	1/4
TP-025-327	1 3/4	2 1/8	3/16	TP-042-345	4	4 3/8	3/16	TP-069-448	9 1/2	10	1/4
TP-026-328	1 7/8	2 1/4	3/16	TP-043-346	4 1/8	4 1/2	3/16	TP-070-449	10	10 1/2	1/4
TP-027-329	2	2 3/8	3/16	TP-045-348	3 3/4	4 3/4	3/16	TP-071-450	10 1/2	11	1/4
TP-028-330	2 1/8	2 1/2	3/16	TP-046-349	4 1/2	4 7/8	3/16	TP-072-451	11	11 1/2	1/4
TP-029-331	2 1/4	2 5/8	3/16	TP-047-350	4 5/8	5	3/16	TP-073-452	11 1/2	12	1/4

All dimensions in inches

Rod T-Seals

The T-Seal is used in reciprocating hydraulic and pneumatic equipment and in high-pressure applications. It fits into the same simple groove as O-Rings and eliminates rolling or spiralling, even under long stroke or dry rod conditions. It does not wedge into clearances or pinch off under motion and/or pressure as well as having good low-pressure sealing capabilities.

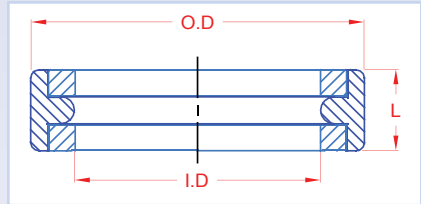

Part Number	I.D.	O.D.	L.	Part Number	I.D.	O.D.	L.	Part Number	I.D.	O.D.	L.
TR-001-106	3/16	3/8	3/32	TR-025-327	1 3/4	2 1/8	3/16	TR-042-344	3 7/8	4 1/4	3/16
TR-004-204	3/8	5/8	1/8	TR-026-328	1 7/8	2 1/4	3/16	TR-043-345	4	4 3/8	3/16
TR-006-206	1/2	3/4	1/8	TR-027-329	2	2 3/8	3/16	TR-045-347	4 1/4	4 5/8	3/16
TR-008-208	5/8	7/8	1/8	TR-028-330	2 1/8	2 1/2	3/16	TR-046-348	4 3/8	4 3/4	3/16
TR-009-209	11/16	15/16	1/8	TR-029-331	2 1/4	2 5/8	3/16	TR-047-349	4 1/2	4 7/8	3/16
TR-010-210	3/4	1	1/8	TR-030-332	2 3/8	2 3/4	3/16	TR-048-429	5	5 1/2	1/4
TR-012-212	7/8	1 1/8	1/8	TR-031-333	2 1/2	2 7/8	3/16	TR-049-431	5 1/4	5 3/4	1/4
TR-014-214	1	1 1/4	1/8	TR-032-334	2 5/8	3	3/16	TR-050-433	5 1/2	6	1/4
TR-015-215	1 1/16	1 5/16	1/8	TR-033-335	2 3/4	3 1/8	3/16	TR-052-437	6	6 1/2	1/4
TR-016-216	1 1/8	1 3/8	1/8	TR-034-336	2 7/8	3 1/4	3/16	TR-058-443	7 1/2	8	1/4
TR-017-217	1 3/16	1 7/16	1/8	TR-035-337	3	3 3/8	3/16	TR-059-445	8	8 1/2	1/4
TR-018-218	1 1/4	1 1/2	1/8	TR-036-338	3 1/8	3 1/2	3/16	TR-060-447	9	9 1/2	1/4
TR-020-220	1 3/8	1 5/8	1/8	TR-037-339	3 1/4	3 5/8	3/16				
TR-022-222	1 1/2	1 3/4	1/8	TR-038-341	3 1/2	3 7/8	3/16				
TR-023-325	1 1/2	1 7/8	3/16	TR-040-342	3 5/8	4	3/16				
TR-024-326	1 5/8	2	3/16	TR-041-343	3 3/4	4 1/8	3/16				

All dimensions in inches

PISTON SEALS

CPS Piston Seals

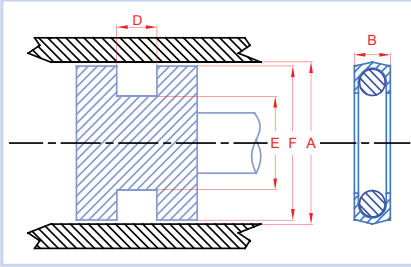

The CPS profile is a tough durable piston seal used to replace O-Rings, Quad Rings and/or T-Seals. The CPS Seal offers better wear resistance compared to standard nitrile materials, due to the CPS profile being energised by an O-Ring to give more positive sealing (0-350bar).

Part Number	A Cylinder diameter	Tolerance	B Seal Length	D Groove Width +0.010/-0	E Groove Diameter	Tolerance	F Piston Diameter	Tolerance
CPS-212	1.125	+0.002/-0	0.150	0.185	0.879	+0.002/-0	1.123	+0.002/-0
CPS-218	1.500	+0.002/-0	0.150	0.185	1.254	+0.002/-0	1.498	+0.002/-0
CPS-222	1.750	+0.002/-0	0.150	0.185	1.504	+0.002/-0	1.748	+0.002/-0
CPS-325	1.875	+0.002/-0	0.255	0.280	1.500	+0.002/-0	1.873	+0.002/-0
CPS-326	2.000	+0.002/-0	0.255	0.280	1.625	+0.002/-0	1.998	+0.002/-0
CPS-328	2.250	+0.002/-0	0.255	0.280	1.875	+0.002/-0	2.248	+0.002/-0
CPS-329	2.375	+0.002/-0	0.255	0.280	2.000	+0.002/-0	2.373	+0.002/-0
CPS-330	2.500	+0.002/-0	0.255	0.280	2.125	+0.002/-0	2.498	+0.002/-0
CPS-332	2.750	+0.004/-0	0.255	0.280	2.374	+0.004/-0	2.747	+0.004/-0
CPS-334	3.000	+0.004/-0	0.255	0.280	2.624	+0.004/-0	2.997	+0.004/-0
CPS-336	3.250	+0.004/-0	0.255	0.280	2.874	+0.004/-0	3.247	+0.004/-0
CPS-337	3.375	+0.004/-0	0.255	0.280	3.000	+0.004/-0	3.373	+0.004/-0
CPS-338	3.500	+0.004/-0	0.255	0.280	3.125	+0.004/-0	3.498	+0.004/-0
CPS-339	3.625	+0.004/-0	0.255	0.280	3.250	+0.004/-0	3.623	+0.004/-0
CPS-340	3.750	+0.004/-0	0.255	0.280	3.375	+0.004/-0	3.748	+0.004/-0
CPS-342	4.000	+0.004/-0	0.255	0.280	3.625	+0.004/-0	3.998	+0.004/-0
CPS-344	4.250	+0.004/-0	0.255	0.280	3.875	+0.004/-0	4.248	+0.004/-0
CPS-346	4.500	+0.004/-0	0.255	0.280	4.125	+0.004/-0	4.498	+0.004/-0
CPS-347	4.625	+0.004/-0	0.255	0.280	4.250	+0.004/-0	4.623	+0.004/-0
CPS-350	5.000	+0.004/-0	0.255	0.280	4.626	+0.004/-0	4.999	+0.004/-0
CPS-429	5.500	+0.004/-0	0.320	0.365	5.021	+0.004/-0	4.999	+0.004/-0
CPS-433	6.000	+0.004/-0	0.320	0.365	5.521	+0.004/-0	5.999	+0.004/-0
CPS-437	6.500	+0.006/-0	0.320	0.365	6.020	+0.006/-0	6.498	+0.006/-0
CPS-439	7.000	+0.006/-0	0.320	0.365	6.520	+0.006/-0	6.998	+0.006/-0
CPS-440	7.250	+0.006/-0	0.320	0.365	6.770	+0.006/-0	7.248	+0.006/-0
CPS-441	7.500	+0.006/-0	0.320	0.365	7.020	+0.006/-0	7.498	+0.006/-0
CPS-442	7.750	+0.006/-0	0.320	0.365	7.270	+0.006/-0	7.748	+0.006/-0
CPS-443	8.000	+0.006/-0	0.320	0.365	7.520	+0.006/-0	7.998	+0.006/-0
CPS-444	8.250	+0.006/-0	0.320	0.365	7.770	+0.006/-0	8.248	+0.006/-0
CPS-445	8.500	+0.006/-0	0.320	0.365	8.020	+0.006/-0	8.498	+0.006/-0
CPS-446	9.000	+0.006/-0	0.320	0.365	8.520	+0.006/-0	8.998	+0.006/-0
CPS-447	9.500	+0.006/-0	0.320	0.365	9.020	+0.006/-0	9.498	+0.006/-0
CPS-448	10.000	+0.006/-0	0.320	0.365	9.520	+0.006/-0	9.998	+0.006/-0
CPS-449	10.500	+0.006/-0	0.320	0.365	10.020	+0.006/-0	10.498	+0.006/-0
CPS-450	11.000	+0.006/-0	0.320	0.365	10.520	+0.006/-0	10.998	+0.006/-0
CPS-451	11.500	+0.006/-0	0.320	0.365	11.020	+0.006/-0	11.498	+0.006/-0
CPS-452	12.000	+0.006/-0	0.320	0.365	11.520	+0.006/-0	11.998	+0.006/-0
CPS-453	12.500	+0.006/-0	0.320	0.365	12.020	+0.006/-0	12.998	+0.006/-0
CPS-454	13.000	+0.006/-0	0.320	0.365	12.998	+0.006/-0	12.998	+0.006/-0
CPS-456	14.000	+0.006/-0	0.320	0.365	13.998	+0.006/-0	13.998	+0.006/-0

All dimensions in inches

PS500 Piston Seals

PS500 is a double acting, low friction, O-Ring energised piston seal for high temperature applications up to approximately 200°C. The Nitrile O-Ring energiser can be interchanged for fluorocarbon material.

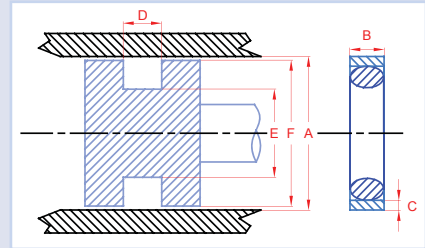

Part Number	A Cylinder Diameter +/- .001	B Seal Height +0.005/-0	C Seal Cross Section +.005/-0	D Groove Width +0/--.003	E Groove Diameter +0/- .003	F Piston Diameter	Tolerance
PSS00-16	1.000	0.088	0.055	0.094	0.787	0.999	+0/-0.003
PSS00-18	1.125	0.088	0.055	0.094	0.912	1.124	+0/-0.003
PSS00-20	1.250	0.088	0.055	0.094	1.037	1.249	+0/-0.003
PSS00-22	1.375	0.088	0.055	0.094	1.162	1.374	+0/-0.003
PSS00-24	1.500	0.088	0.055	0.094	1.287	1.499	+0/-0.003
PSS00-26	1.625	0.088	0.055	0.094	1.412	1.624	+0/-0.003
PSS00-28	1.750	0.088	0.055	0.094	1.473	1.749	+0/-0.003
PSS00-30	1.875	0.120	0.055	0.126	1.598	1.874	+0/-0.003
PSS00-32	2.000	0.120	0.055	0.126	1.723	1.999	+0/-0.003
PSS00-36	2.250	0.120	0.055	0.126	1.937	2.249	+0/-0.003
PSS00-38	2.375	0.120	0.055	0.126	2.098	2.374	+0/-0.003
PS500-40	2.500	0.120	0.055	0.126	2.223	2.499	+0/-0.003
PS500-44	2.750	0.150	0.085	0.157	2.348	2.749	+0/-0.004
PS500-48	3.000	0.150	0.085	0.157	2.603	2.999	+0/-0.004
PS500-52	3.250	0.150	0.085	0.157	2.853	3.249	+0/-0.004
PS500-56	3.500	0.150	0.085	0.157	3.103	3.499	+0/-0.004
PS500-60	3.750	0.150	0.085	0.157	3.353	3.749	+0/-0.004
PS500-64	4.000	0.150	0.085	0.157	3.600	3.999	+0/-0.004
PS500-68	4.250	0.150	0.085	0.157	3.853	4.249	+0/-0.004
PS500-72	4.500	0.150	0.085	0.157	4.103	4.499	+0/-0.004
PS500-76	4.750	0.150	0.085	0.157	4.353	4.749	+0/-0.004
PS500-80	5.000	0.150	0.085	0.157	4.603	4.999	+0/-0.004
PS500-84	5.250	0.150	0.085	0.157	4.853	5.249	+0/-0.004
PS500-88	5.500	0.150	0.085	0.157	5.103	5.499	+0/-0.004
PS500-92	5.750	0.150	0.085	0.157	5.353	5.749	+0/-0.004
PS500-96	6.000	0.287	0.120	0.293	5.305	5.999	+0/-0.005
PS500-112	7.000	0.287	0.120	0.293	6.305	6.999	+0/-0.005

All dimensions in inches



Introduction

The primary function of a wiper is to prevent moisture, dust, grit and other contaminants entering a system. A correctly selected Wiper Seal will vastly reduce system damage and potential failure of hydraulic systems, precision valves, seals and other sensitive components that are vulnerable to contamination.

D-Style Wiper

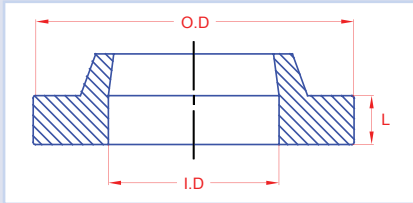

D-Style Wipers are used for light duty low friction applications. Manufactured from Polyurethane, suitable for speeds up to 1.0m/s and a temperature range of approximately -40°C to 90°C.

Part Number	I.D.	O.D.	L	Part Number	I.D.	O.D.	L	Part Number	I.D.	O.D.	L
DSW-250	1/4	1/2	1/8	DSW-2250	2 1/4	2 3/4	1/4	DSW-5750	5 3/4	6 1/2	3/8
DSW-375	3/8	5/8	1/8	DSW-2375	2 3/8	2 7/8	1/4	DSW-6000	6	6 3/4	3/8
DSW-437	7/16	11/16	1/8	DSW-2500	2 1/2	3	1/4	DSW-6250	6 1/4	7	3/8
DSW-500	1/2	3/4	1/8	DSW-2625	2 5/8	3 1/8	1/4	DSW-6500	6 1/2	7 1/4	3/8
DSW-562	9/16	13/16	1/8	DSW-2750	2 3/4	3 1/4	1/4	DSW-6600	6 1/2	7 1/2	1/2
DSW-625	5/8	7/8	1/8	DSW-2875	2 7/8	3 3/8	1/4	DSW-6750	6 3/4	7 1/2	3/8
DSW-750	3/4	1 1/8	3/16	DSW-3000	3	3 1/2	1/4	DSW-7000	7	7 3/4	3/8
DSW-875	7/8	1 1/4	3/16	DSW-3125	3 1/8	3 5/8	1/4	DSW-7010	7	8	1/2
DSW-937	15/16	1 5/16	3/16	DSW-3250	3 1/4	3 3/4	1/4	DSW-7500	7 1/2	8 1/4	3/8
DSW-1000	1	1 3/8	3/16	DSW-3375	3 3/8	3 7/8	1/4	DSW-7750	7 3/4	8 1/2	3/8
DSW-1125	1 1/8	1 1/2	3/16	DSW-3500	3 1/2	4	1/4	DSW-8000	8	8 3/4	3/8
DSW-1187	1 3/16	1 9/16	3/16	DSW-3625	3 5/8	4 1/8	1/4	DSW-8010	8	8 1/2	1/4
DSW-1250	1 1/4	1 5/8	3/16	DSW-3750	3 3/4	4 1/4	1/4	DSW-8250	8 1/4	9	3/8
DSW-1312	1 5/16	1 11/16	3/16	DSW-3875	3 7/8	4 3/8	1/4	DSW-8500	8 1/2	9 1/4	3/8
DSW-1375	1 3/8	1 3/4	3/16	DSW-4000	4	4 1/2	1/4	DSW-8510	8 1/2	9	1/4
DSW-1437	1 7/16	1 13/16	3/16	DSW-4125	4 1/8	4 5/8	1/4	DSW-8750	8 3/4	9 1/2	3/8
DSW-1500	1 1/2	1 7/8	3/16	DSW-4250	4 1/4	4 3/4	1/4	DSW-9000	9	9 3/4	3/8
DSW-1562	1 9/16	1 15/16	3/16	DSW-4375	4 3/8	4 7/8	1/4	DSW-9500	9 1/2	10 1/4	3/8
DSW-1625	1 5/8	2	3/16	DSW-4500	4 1/2	5 1/4	3/8	DSW-9750	9 3/4	10 1/2	3/8
DSW-1750	1 3/4	2 1/8	3/16	DSW-4750	4 3/4	5 1/2	3/8	DSW-10000	10	11	1/2
DSW-1875	1 7/8	2 1/4	3/16	DSW-4875	4 7/8	5 5/8	3/8	DSW-10500	10	10 1/2	1/4
DSW-1937	1 15/16	2 5/16	3/16	DSW-5000	5	5 3/4	3/8	DSW-11000	11	12	1/2
DSW-2000	2	2 1/2	1/4	DSW-5250	5 1/4	6	3/8	DSW-12000	12	13	1/2
DSW-2125	2 1/8	2 5/8	1/4	DSW-5500	5 1/2	6 1/4	3/8	DSW-12010	12	13 1/4	1/2

All dimensions in inches

J-Can Wiper

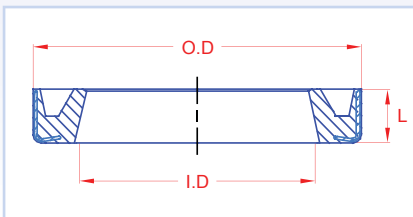

J-Can Wipers are encased in metal. This makes them ideal solution for a wiper application within harsh environments for heavy duty purposes. Manufactured from Polyurethane, suitable for speeds up to 1.0m/s and a temperature range of approximately -40°C to 90°C.

Slotted Heel Wiper

The **Slotted Heel Wiper** is designed to prevent a build-up of pressure and fluid from rod seal seepage. Manufactured from Polyurethane, suitable for speeds up to 1.0m/s and a temperature range of approximately -40°C to 90°C.

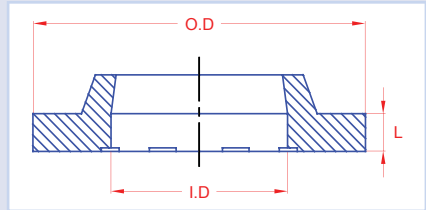

Part Number	I.D.	O.D.	L	Part Number	I.D.	O.D.	L	Part Number	I.D.	O.D.	L
SHW-625	5/8	7/8	1/8	SHW-1750	1 3/4	2 1/8	3/16	SHW-4250	4 1/4	4 3/4	1/4
SHW-750	3/4	1 1/8	3/16	SHW-2000	2	2 1/2	1/4	SHW-4500	4 1/2	5 1/4	3/8
SHW-875	7/8	1 1/4	3/16	SHW-2250	2 1/4	2 3/4	1/4	SHW-4750	4 3/4	5 3/4	3/8
SHW-1000	1	1 3/8	3/16	SHW-2500	2 1/2	3	1/4	SHW-5000	5	5 3/4	3/8
SHW-1125	1 1/8	1 1/2	3/16	SHW-2750	2 3/4	3 1/4	1/4	SHW-5250	5 1/4	6	3/8
SHW-1250	1 1/4	1 5/8	3/16	SHW-3000	2	3 1/2	1/4	SHW-6000	6	6 3/4	3/8
SHW-1375	1 3/8	1 3/4	3/16	SHW-3500	3 1/2	4	1/4				
SHW-1500	1 1/2	1 7/8	3/16	SHW-4000	4	4 1/2	1/4				

All dimensions in inches

H-Style Wipers are one-piece snap-in type rod wiper. The H-Style provides both wiper lip and secondary fluid seal. H-Style wipers can be installed in D-Style wiper grooves. Standard H-style wipers are manufactured from polyurethane, suitable for speeds up to 1.0m/s and a temperature range of approximately -40°C to 90°C.

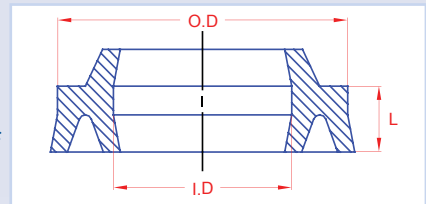

Other materials are available on request including Nitrile and Viton.

Part Number	I.D.	O.D.	L	Part Number	I.D.	O.D.	L	Part Number	I.D.	O.D.	L
HSW-0500	1/2	13/16	0.194	HSW-1875	1 7/8	2 1/4	0.212	HSW-4250	4 1/4	4 3/4	0.275
HSW-0625	5/8	15/16	0.194	HSW-2000	2	2 3/8	0.212	HSW-4430	4 7/16	4 15/16	0.275
HSW-0625-1	5/8	1	0.203	HSW-2125	2 1/8	2 1/2	0.212	HSW-4500	4 1/2	5	0.275
HSW-0750	3/4	1 1/16	0.194	HSW-2250	2 1/4	2 3/4	0.275	HSW-4750	4 3/4	5 1/4	0.275
HSW-0875	7/8	1 1/14	0.212	HSW-2500	2 1/2	3	0.275	HSW-5000	5	5 1/2	0.275
HSW-1000	1	1 3/8	0.212	HSW-2625	2 5/8	3 1/8	0.275	HSW-5500	5 1/2	6	0.275
HSW-1125	1 1/8	1 1/2	0.212	HSW-2750	2 3/4	3 1/4	0.275	HSW-6000	6	6 1/2	0.275
HSW-1250	1 1/4	1 5/8	0.212	HSW-3000	3	3 1/2	0.275	HSW-7000	7	7 1/2	0.275
HSW-1375	1 3/8	1 3/4	0.212	HSW-3250	3 1/4	3 3/4	0.275	HSW-8000	8	8 1/2	0.275
HSW-1500	1 1/2	1 7/8	0.212	HSW-3500	3 1/2	4	0.275				
HSW-1625	1 5/8	2	0.212	HSW-3750	3 3/4	4 1/4	0.275				
HSW-1750	1 3/4	2 1/8	0.212	HSW-4000	4	4 1/2	0.275				

All dimensions in inches

WIPER RINGS

K-Style Wiper

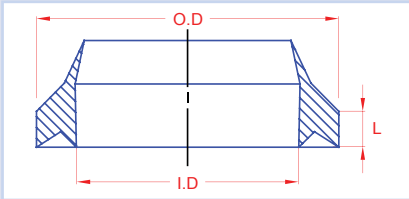

K-Style Wipers are one-piece snap-in type rod wiper. The K-Style provides both wiper lip and secondary fluid seal. K-Style wipers can only be installed in K-Style grooves. Manufactured from polyurethane, suitable for speeds up to 1.0m/s and a temperature range of approximately -40°C to 90°C.

Part Number	I.D.	O.D.	L	Part Number	I.D.	O.D.	L	Part Number	I.D.	O.D.	L
KSW-0500	1/2	3/4	0.156	KSW-2125	2 1/8	2 1/2	0.190	KSW-3750	3 3/4	5	0.250
KSW-0625	5/8	7/8	0.156	KSW-2210	2 7/32	2 23/32	0.250	KSW-4000	4	4 1/2	0.250
KSW-0750	3/4	1 1/8	0.190	KSW-2250	2 1/4	2 3/4	0.250	KSW-4060	4 1/16	4 9/16	0.250
KSW-0875	7/8	1 1/4	0.190	KSW-2500	2 1/2	3	0.250	KSW-4500	4 1/2	5	0.250
KSW-1000	1	1 3/8	0.190	KSW-2500-1	2 1/2	2 7/8	0.190	KSW-4875	4 7/8	5 3/8	0.250
KSW-1125	1 1/8	1 1/2	0.190	KSW-2625	2 5/8	3 1/8	0.250	KSW-5000	5	5 1/2	0.250
KSW-1250	1 1/4	1 5/8	0.190	KSW-2750	2 3/4	3 1/4	0.250	KSW-5375	5 3/8	5 7/8	0.250
KSW-1375	1 3/8	1 3/4	0.190	KSW-3000	3	3 1/2	0.250	KSW-6000	6	6 1/2	0.250
KSW-1500	1 1/2	1 7/8	0.190	KSW-3250	3 1/4	3 3/4	0.250	KSW-6250	6 1/4	6 3/4	0.250
KSW-1625	1 5/8	2	0.190	KSW-3375	3 3/8	3 7/8	0.250	KSW-7000	7	7 1/2	0.250
KSW-1750	1 3/4	2 1/8	0.190	KSW-3500	3 1/2	4	0.250	KSW-8000	8	8 1/2	0.250
KSW-2000	2	2 3/8	0.190	KSW-3500-2	3 1/2	3 7/8	0.190				

All dimensions in inches

WR95 Wiper

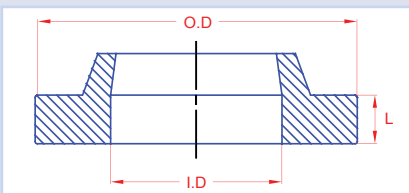

WR95 Wipers are durable hard wearing polyurethane snap-in scraper. The last two digits correspond to the MS28776 range of wipers.

Part Number	I.D.	O.D.	L	Part Number	I.D.	O.D.	L	Part Number	I.D.	O.D.	L
WR95-01	0.498	0.760	0.104	WR95-25	2.498	2.802	0.104	WR95-49	5.497	5.927	0.135
WR95-02	0.560	0.823	0.104	WR95-26	2.623	2.989	0.119	WR95-50	5.622	6.114	0.151
WR95-03	0.623	0.885	0.104	WR95-27	2.748	3.114	0.119	WR95-51	5.747	6.239	0.151
WR95-04	0.685	0.948	0.104	WR95-28	2.873	3.239	0.119	WR95-52	5.872	6.364	0.151
WR95-05	0.748	1.010	0.104	WR95-29	2.997	3.364	0.119	WR95-53	5.997	6.489	0.151
WR95-06	0.810	1.084	0.104	WR95-30	3.119	3.489	0.119	WR95-54	6.247	6.739	0.151
WR95-07	0.873	1.147	0.104	WR95-31	3.247	3.614	0.119	WR95-55	6.497	6.989	0.151
WR95-08	0.935	1.209	0.104	WR95-32	3.372	3.729	0.119	WR95-56	6.747	7.239	0.151
WR95-09	0.998	1.272	0.104	WR95-33	3.497	3.864	0.119	WR95-57	6.997	7.484	0.151
WR95-10	1.060	1.334	0.104	WR95-34	3.622	3.989	0.119	WR95-58	7.247	7.739	0.151
WR95-11	1.123	1.397	0.104	WR95-35	3.747	4.114	0.119	WR95-59	7.497	7.989	0.151
WR95-12	1.185	1.459	0.104	WR95-36	3.872	4.239	0.119	WR95-60	7.750	8.247	0.151
WR95-13	1.248	1.522	0.104	WR95-37	3.997	4.427	0.135	WR95-61	7.997	8.484	0.151
WR95-14	1.310	1.614	0.104	WR95-38	4.119	4.552	0.135	WR95-62	8.497	8.989	0.151
WR95-15	1.373	1.677	0.104	WR95-39	4.247	4.677	0.135	WR95-63	9.000	9.497	0.151
WR95-16	1.435	1.739	0.104	WR95-40	4.372	4.802	0.135	WR95-65	9.998	10.497	0.151
WR95-17	1.498	1.802	0.104	WR95-41	4.497	4.927	0.135	WR95-66	10.497	10.997	0.151
WR95-18	1.623	1.927	0.104	WR95-42	4.622	5.052	0.135				
WR95-19	1.748	2.052	0.104	WR95-43	4.747	5.177	0.135				
WR95-20	1.873	2.177	0.104	WR95-44	4.872	5.302	0.135				
WR95-21	1.998	2.302	0.104	WR95-45	4.997	5.427	0.135				
WR95-22	2.123	2.427	0.104	WR95-46	5.122	5.552	0.135				
WR95-23	2.248	2.552	0.104	WR95-47	5.247	5.677	0.135				
WR95-24	2.373	2.677	0.104	WR95-48	5.372	5.802	0.135				

All dimensions in inches

Introduction

Flexi-Wear Rings and tapes prevent metallic contact between a piston and cylinder with laterally acting forces. The guiding elements are wearing parts that can easily be exchanged together with the seals and are therefore cost-effective. We supply a variety of materials suitable for nearly every application.

Availability

Basic materials offered include thermoplastics, filled-thermoplastics, duroplastic resins with fabric reinforcement, guiding tapes in PTFE with bronze or carbon additives, polyamide and other plastics.

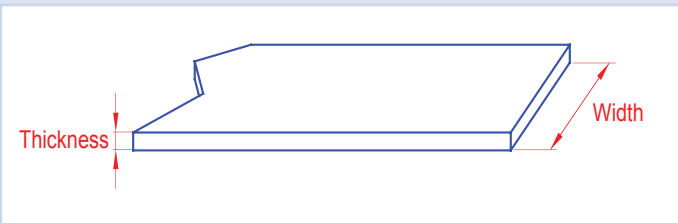

Part Number	Width	Thickness	Filler	Part Number	Width	Thickness	Filler
BFWR-T-025-062	1/4	1/16	Bronze	BFWR-T-037-125	3/4	1/8	Bronze
BFWR-T-050-062	1/2	1/16	Bronze	BFWR-T-075-125	1/4	1/8	Bronze
BFWR-T-062-062	5/8	1/16	Bronze	BFWR-T-100-125	1	1/8	Bronze
BFWR-T-075-062	3/4	1/16	Bronze	BFWR-T-050-125	1/2	1/8	Bronze
BFWR-T-100-062	1	1/16	Bronze	BFWR-T-062-125	5/8	1/8	Bronze
BFWR-T-075-093	3/4	3/32	Bronze				
BFWR-T-100-093	1 1/4	3/32	Bronze				
BFWR-T-125-093	3/8	3/32	Bronze				

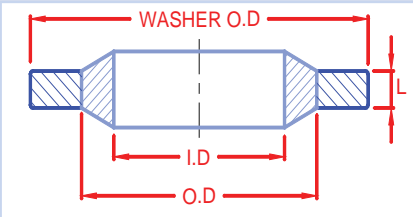

Bonded Washers

In the field of engineering bonded washers are widely used. This helps prevent leakage in the most intricate to the basic nut and bolt assemblies. The sealing abilities remain reliable at both high and low temperatures and pressures.

PR-7500 Thread-seal self-centring washers are used to seal threaded components. The triangular rubber mouldings aid centralisation on the thread for increased ease of use. PR-7500 washers can also be reused if the rubber is free from damage.

Availability

For better performance and durability we would recommend using stainless steel self-centralising bonded washers instead of mild steel versions, however we do supply both.

Celok Washers

Celok Washers are ideal for applications where vibration occurs. When load is applied on to conventional serrated metal washers the serrated edges bite into the surface. This locking action increases the fastener's ability to resist vibration.

Celok washers improve on this design by utilising a rubber coating which prevents moisture ingress and reduces the risk of corrosion or oxidation.

Availability

The coating is manufactured in NBR (Nitrile Butadiene Rubber) as standard, though other compounds are available on request.

Moulded Rubber

Klinger Acorn supplies a range of moulded rubber products in a wide variety of elastomeric materials. Facilities include production of precision moulded tools, as well as temporary tools for one-off small quantity batches. Full 2D and 3D capability is available to produce single cavity compression tools through multi-cavity injection moulds. Moulds can be manufactured to either customer specification or from existing samples.

Availability

Polyurethane, Nitrile, EPDM & Viton



Chevron Seals

Chevrons also known as VEE-packing, and are often used for sealing rods, pistons and plungers in hydraulic cylinders and hydraulic presses. Chevron Sets are suitable for medium to heavy duty applications, low and high pressures, arduous conditions and misalignment between sealing gaps.

The seal is a combination of a base seal, centre rings and pressure ring. The centre rings are the main seal, being flexible enough to retain the system pressure, whereas the base seal prevents the centre ring from being extruded against high pressures. The pressure rings help retain the centre rings' profile and distribute the load equally between all the rings.

Availability

Standard material available for Chevron packings are fabric reinforced Nitrile rubber with nylon base seal and pressure ring. Polyurethane centre rings are also available.

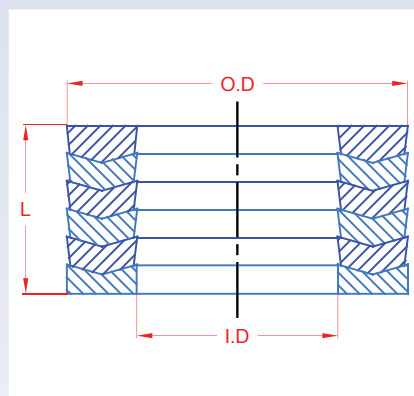



85g Tube



14g Tub & 85g Tube

Super Lube Dielectric Grease

Super Lube® Silicone Dielectric Grease is a non-curing Silicone compound utilized for sealing, protecting and insulating electrical components and connectors.

Super Lube® Silicone Dielectric Grease is waterproof and protects against moisture and other contaminants in electrical connections.

Super Lube® Silicone Dielectric Grease is translucent white, clean and clear in appearance and exhibits high dielectric strength and is compatible with most plastics.

Super Lube® Silicone Dielectric Grease withstands temperatures from -40°C to 260°C.

Availability

- 14g Tube
- 85g Tube
- 400g Canister
- Other sizes available on request

Super Lube Synthetic Oil with PTFE

Super Lube Oil with PTFE is a premium synthetic oil with suspended PTFE particles that bond to surface and add lubricity to moving parts.

Super Lube Oil is used for applications which allow parts to be confined (i.e. gearboxes). It is used as a general purpose lubricant for industrial machinery and equipment. With benefits such as providing long-life protection against friction, wear, rust and corrosion, machinery lasts longer, downtime is reduced and productivity is increased, plus it is safe on metal, rubber, plastic, wood, leather, fabric and painted surfaces.

Availability

- 7ml Precision Oiler Pen
- 115ml Bottle
- 1l Bottle



115ml Bottle



7ml Precision Oiler



85g Tube



310ml Aerosol



400g Cartridge

Super Lube Multi-Purpose Grease

Super Lube is a patented synthetic NLGI grade 2 heavy-duty multi-purpose lubricant with added PTFE. Its synthetic base fluids and the addition of PTFE micropowders combine to form a premium lubricant that is compatible with most other lubricants.

Super Lube is a USDA listed Food Grade lubricant, rated H1 for incidental food contact. Its grease outlasts conventional greases by approximately 50-100% and has excellent adhesion.

Super Lube grease can be used to assist the fitting of O-rings and as an anti-seize on rubber and plastic components.

Availability

- 12g Tube
- 85g Tube
- 85g Cartridge
- 400g Canister
- 400g Cartridge
- 310ml Aerosol

Super Lube Anti-Corrosion Gel

Super Lube® Anti-Corrosion Gel is a specially formulated high molecular weight connector gel used as a dielectric compound and as a corrosion inhibitor. It is an effective dielectric compound and corrosion inhibitor for plugs and connectors, electrical terminals, electrical fittings, spark plugs and coil connectors. It is a superior oxidation barrier.

Note: Should not be used as a lubricant.

Availability

85g Tube
400g Canister



Super Lube Dri-Lube

Super Dri-Lube is a self-cleaning lubricant that actually cleans while lubricating. It leaves behind a protective shield lubricant that will not attract dust. The dry coating provides a low coefficient of friction which gives excellent lubrication and release properties.

Dri-Lube can be used on wood, metal and most plastics not under stress and has excellent thermal and chemical stability, forming a natural insulating barrier when used on electronics.

Approved under MIL-60326(MU) amendment 1.

Availability

310ml Aerosol



310ml Aerosol

Klinger Acorn



Introduction

Klinger Acorn can also supply a range of accessories for use with O-rings, these include measurement tools and installation and removal tools.

Sizing Gauges

O-Ring Cones can be used to measure rings with inner diameters from 5/16" up to 5 5/8". The cone also features cut outs to determine the correct cross-section. The cone is manufactured from high density polyethylene.

Pi Tape is calibrated with metric markings to enable easy measurement of the inner diameter. This also provides a reference to the standard O-Ring dimensions. The Pi tape can be used to measure rings with inner diameters between 2" and 13".

The O-Ring Gauge can be used to determine the cross-section and the standard reference number of various rings between 2 1/2" and 16" inner diameter.

Installation Tools

The installation and extraction tools are supplied as kits which includes two double ended tools to help with the installation or removal of O-rings. The tools are manufactured from brass to ensure the precision, machined sealing surfaces are not damaged.

CHEMICAL RESISTANCE CHART FOR HYDRAULIC SEALS

Media	Formula	Nitrile	Ethylene Propylene (EPDM)	Fluorocarbon (Viton)	Perfluoroelastomer (Kalrez)	Neoprene	Polyurethane	Fluorosilicone	Silicone
Acetaldehyde	CH ₃ CHO	C	B	C	A	C	C	C	B
Acetamide	CH ₃ COCH ₂	A	A	C	A	A	C	A	B
Acetic acid (30%)	CH ₃ COOH	C	A	C	A	C	C	C	C
Acetic ether	CH ₃ COOC ₂ H ₅	C	B	C	A	C	C	C	B
Acetone	CH ₃ COCH ₃	C	A	C	A	C	C	C	C
Acetylene	C ₂ H ₂	A	A	A	A	B	C	A	B
Adipic acid	COOH(CH ₂) ₄ COOH	A	B	A	A	A	C	A	A
Alum	KAl(SO ₄) ₂	A	A	C	C	A	B	C	A
Aluminium acetate	(CH ₃ COO) ₃ Al	B	A	C	A	B	C	C	C
Aluminium chlorate	Al(ClO ₃) ₃	C	A	C	A	A	C	A	B
Aluminium chloride	AlCl ₃	A	A	A	A	A	C	A	B
Ammonia, Gas, Cold	NH ₃	A	A	C	C	A	C	C	A
Ammonia, Gas, Hot	NH ₃	C	B	C	C	B	C	C	C
Ammonia, Liquid (Anhydrous)	NH ₃	B	A	C	C	A	C	C	B
Ammonium bicarbonate	NH ₄ HCO ₃	C	A	C	A	A	C	A	B
Ammonium chloride	NH ₄ Cl	A	A	A	A	A	A	A	A
Ammonium diphosphate	(NH ₄) ₂ HPO ₄	C	A	C	A	A	C	A	B
Ammonium hydroxide 3 Molar	NH ₄ OH	A	A	C	B	A	C	A	A
Ammonium hydroxide (con)	NH ₄ OH	C	A	C	C	A	C	A	A
Amyl acetate	CHCOOC ₅ H ₁₁	C	A	C	A	A	C	A	B
Aniline	C ₆ H ₅ NH ₂	C	A	A	A	C	C	C	C
Asphalt (tar)		B	C	A	A	B	B	B	C
ASTM oil 1		A	C	A	A	A	A	A	A
ASTM oil 3		A	C	A	A	C	B	A	C
Barium chloride	BaCl ₂	A	A	A	A	A	A	A	A
Benzene	C ₆ H ₆	C	C	A	A	C	C	C	C
Benzine (Ligroin)		A	C	A	A	B	B	A	C
Benzoic acid	C ₆ H ₅ COOH	C	C	A	A	C	C	B	C
Bleach	Ca(OCl) ₂	C	A	A	A	C	C	C	C
Borax	Na ₂ B ₄ O ₇ ·10H ₂ O	B	A	A	A	C	A	B	B
Butane	C ₄ H ₁₀	A	C	A	A	A	A	C	C
Butanone		C	A	C	A	C	C	C	C
Butyl acetate	CHCOOC ₄ H ₉	C	B	C	A	C	C	C	C
Butyl alcohol (butanol)	C ₄ H ₉ OH	A	B	A	A	A	C	A	B
Calcium chloride	CaCl ₂	A	A	A	A	A	A	A	A
Calcium hydroxide	Ca(OH) ₂	A	A	A	A	A	B	A	A
Calcium sulphate	CaSO ₄	C	A	C	A	A	C	A	B
Carbon dioxide	CO ₂	A	A	A	A	A	A	A	A
Carbon disulphide	CS ₂	C	C	A	A	C	B	A	C
Carbon tetrachloride	CCl ₄	B	C	A	A	C	C	B	C

CHEMICAL RESISTANCE CHART FOR HYDRAULIC SEALS

Media	Formula	Nitrile	Ethylene Propylene (EPDM)	Fluorocarbon (Viton)	Perfluoroelastomer (Kalrez)	Neoprene	Polyurethane	Fluorosilicone	Silicone
Castor oil		A	B	A	A	A	A	A	A
Chlorine (dry)	Cl ₂	C	C	A	A	C	C	A	C
Chlorine water (0.5%)		C	B	A	A	C	C	C	C
Chlorine (wet)	Cl ₂	C	C	B	A	C	C	B	C
Chloroform	CHCl ₃	C	C	A	A	C	C	B	C
Chloromethane	CH ₃ Cl	C	C	B	A	C	C	B	C
Chromic acid	H ₂ CrO ₄	C	B	A	A	C	C	B	C
Citric acid		A	A	A	A	A	A	A	A
Copper acetate	(CH ₃ COO) ₂ Cu	B	A	C	A	B	C	C	C
Copper sulphate	CuSO ₄	A	A	A	A	A	A	A	A
Creosote		A	C	A	A	B	C	A	C
Cresol	C ₆ H ₄ (OH)CH ₃	C	C	B	A	C	C	B	C
Cyclohexanol	C ₆ H ₁₁ OH	A	C	A	A	B	-	A	C
Cyclohexanone	C ₅ H ₁₀ O	C	B	C	A	C	C	C	C
Decalin	C ₁₀ H ₁₈	C	C	A	A	C	B	C	C
Di-benzylether	(C ₆ H ₅ CH ₂) ₂ O	C	B	C	A	C	B	A	B
Di-butylphthalate	C ₆ H ₄ (COOC ₄ H ₉) ₂	C	B	C	A	C	C	C	B
Dimethylformamide	HCON(CH ₃) ₂	B	A	C	A	C	C	C	B
Diphyl (Dowtherm A)		C	C	A	A	C	C	B	C
Ethane	C ₂ H ₆	A	C	A	A	B	C	C	C
Ethyl acetate	CH ₃ COOC ₂ H ₅	C	B	C	A	C	C	C	B
Ethyl alcohol (Ethanol)	C ₂ H ₅ OH	C	A	C	A	A	C	A	B
Ethyl chloride	C ₂ H ₅ Cl	A	C	A	A	C	B	A	C
Ethyl ether	C ₂ H ₅ OC ₂ H ₅	C	C	C	A	C	A	C	C
Ethylene chloride	(CH ₂ Cl) ₂	C	C	B	A	C	C	B	C
Ethylene glycol	(CH ₂ OH) ₂	A	A	A	A	A	B	A	A
Formaldehyde	CH ₂ O	C	B	C	A	C	C	C	B
Formamide	HCONH ₂	C	A	C	A	A	C	A	B
Freon 12		B	C	C	B	A	A	C	C
Freon 22		C	C	C	A	A	C	C	C
Glucose	C ₆ H ₁₂ O ₆	A	A	A	A	A	C	A	A
Glycerine	(CH ₂ OH) ₂ CHOH	A	A	A	A	A	C	A	A
Heptane	C ₇ H ₁₆	A	C	A	A	B	B	C	C
Hydraulic oil (mineral/Glycol)		A	C	A	A	B	C	B	C
Hydraulic oil (phosphate ester)		C	A	A	A	C	C	B	C
Hydrazine hydrate	(NH ₂) ₂ H ₂ O	C	A	C	A	A	C	A	B
Hydrochloric acid 37% (Cold)	HCl	C	C	A	A	C	C	B	C

CHEMICAL RESISTANCE CHART FOR HYDRAULIC SEALS

Media	Formula	Nitrile	Ethylene Propylene (EPDM)	Fluorocarbon (Viton)	Perfluoroelastomer (Kalrez)	Neoprene	Polyurethane	Fluorosilicone	Silicone
Hydrochloric acid 37% (Hot)	HCl	C	C	A	A	C	C	B	C
Hydrofluoric acid (37%)	HF	C	C	A	A	C	C	C	C
Hydrogen	H ₂	A	A	A	A	A	A	C	C
Hydrogen peroxide (<6%ww)	H ₂ O ₂	B	A	A	A	A	B	A	A
Iso-octane	(CH ₃) ₃ CCH ₂ (CH ₃) ₂	A	C	A	A	B	B	A	C
Iso-propyl alcohol	(CH ₃) ₂ CHOH	B	A	A	A	B	C	B	A
Kerosene (petroleum)		A	C	A	A	B	A	A	C
Lead acetate	(CH ₃ COO) ₂ Pb	B	A	C	A	B	C	C	C
Lead arsenate	Pb ₃ (AsO ₄) ₂	B	A	B	A	A	C	A	B
Magnesium sulphate	MgSO ₄	A	A	A	A	A	C	A	A
Methane	CH ₄	A	C	A	A	B	C	C	C
Methyl alcohol	CH ₃ OH	C	A	C	A	A	C	A	A
Methyl chloride	CH ₃ Cl	C	C	A	A	C	C	B	C
Methyl ethyl ketone	CH ₃ COO, H ₅	C	A	C	A	C	C	B	C
Methylene chloride	CH ₂ Cl ₂	C	C	B	A	C	C	B	C
Naphtha		B	C	A	A	C	B	B	C
Nitrobenzene	C ₆ H ₅ NO ₂	C	A	B	A	C	C	C	C
Nitrogen	N ₂	A	A	A	A	A	A	A	A
Nitric Acid (conc. 0-50%)	HNO ₃	C	B	A	A	C	C	C	C
Octane	C ₈ H ₁₈	A	C	A	A	C	C	B	C
Oleum (fuming sulphuric acid)		C	C	A	A	C	C	C	C
Oxalic acid	HO ₂ CCO ₂ H	B	A	A	A	B	C	A	B
Oxygen (Cold)	O ₂	B	A	A	A	A	A	A	A
Pentane	C ₅ H ₁₂	A	C	A	A	A	C	C	C
Perchloroethylene	C ₂ Cl ₄	B	C	A	A	C	C	B	C
Petroleum ether		A	B	A	A	B	A	A	B
Phenol	C ₆ H ₅ OH	C	C	A	A	C	C	B	C
Phosphoric acid (concentrated)	H ₃ PO ₄	B	A	A	A	B	C	C	C
Phthalic acid	(C ₆ H ₄ COOH) ₂	C	A	C	A	A	C	A	B
Potassium acetate	CH ₃ COOK	B	A	C	A	B	C	C	C
Potassium carbonate	K ₂ CO ₃	C	A	C	A	B	C	C	C
Potassium chlorate	KClO ₃	C	A	C	A	A	C	A	B
Potassium chloride	KCl	C	A	C	A	A	C	A	B
Potassium cyanide	KCN	A	A	A	A	A	A	A	A
Potassium dichromate	K ₂ Cr ₂ O ₇	A	A	A	A	A	B	A	A

CHEMICAL RESISTANCE CHART FOR HYDRAULIC SEALS

Media	Formula	Nitrile	Ethylene Propylene (EPDM)	Fluorocarbon (Viton)	Perfluoroelastomer (Kalrez)	Neoprene	Polyurethane	Fluorosilicone	Silicone
Potassium hydroxide	KOH	B	A	C	A	B	C	C	C
Potassium hypochlorite	KClO	C	A	C	A	A	C	A	B
Potassium nitrate	KNO ₃	A	A	A	A	A	A	A	A
Potassium permanganate	KMnO ₄	C	A	C	A	A	C	A	B
Propane	C ₃ H ₈	A	B	A	A	B	C	B	C
Pyridine	C ₅ H ₅ N	C	B	A	A	C	C	B	C
Salt	NaCl	A	A	A	A	A	A	A	A
Silicone oil		A	A	A	A	A	A	C	C
Soda	Na ₂ CO ₃								
Sodium aluminate	Na ₂ AlO ₃	C	A	C	A	A	C	A	B
Sodium bisulphite	NaHSO ₃	A	A	A	A	A	A	A	A
Sodium carbonate	NaHCO ₃	A	A	A	A	A	B	A	A
Sodium chloride	NaCl	A	A	A	A	A	A	A	A
Sodium cyanide	NaCN	A	A	A	A	A	B	A	A
Sodium hydroxide	NaOH	B	A	B	A	B	B	B	A
Sodium silicate (water glass)		A	A	A	A	A	B	A	A
Sodium sulphate	Na ₂ SO ₄	A	A	A	A	A	A	A	A
Sodium sulphide	Na ₂ S	A	A	A	A	A	A	A	A
Steam	H ₂ O								
Stearic acid	C ₁₇ H ₃₅ COOH	B	B	A	A	B	A	B	B
Sulphur dioxide	SO ₂	C	A	C	A	C	C	B	B
Sulphuric acid	H ₂ SO ₄								
Tetrachloroethane	C ₂ H ₂ Cl ₄	C	C	A	A	C	C	B	C
Tetraline	C ₁₀ H ₁₂	C	C	A	A	C	C	A	C
Toluene	C ₆ H ₅ CH ₃	C	C	A	A	C	C	B	C
Transformer oil		A	C	A	A	B	A	A	B
Trichloroethylene	C ₂ HCl ₃	C	C	A	A	C	C	B	C
Triethanolamine	N(CH ₂ CH ₂ OH) ₃	C	B	C	A	B	C	C	C
Urea	(NH ₂) ₂ CO	B	A	A	A	B	B	A	B
Vinyl acetate	CH ₃ COOC ₂ H ₅	B	A	C	A	B	C	-	C
Water	H ₂ O	B	A	A	A	B	A	A	B
Xylo	C ₆ H ₄ (CH ₃) ₂	C	C	A	A	C	C	A	C



Boiler Door Joints



Ceramic Tape



Spectacle Plates, Spades & Slip Plates

Additional Products

Additional Products

Klinger Water-jet Cutting Services 286

Klinger-Hadley; Plate Flanges, Blanks, Slip & Spectacle Plates 288

Klinger Precision Engineering 289

Boiler Door Joints 290

Ceramic Tape 291

Stainless Steel Hoses 292





The System

Water-jet cutting offers consistent precision results, producing finished parts from a wide and varied range of materials.

Designed to complement or replace existing processes such as milling, laser, wire EDM and plasma. The software allows us to download DXF and DWG files to enable a speedy response to enquiries.

The Process

We can machine complex parts from most materials including metal, plastic, glass, ceramics and composites.

The accuracy of the components produced varies from $\pm 0.001''$ (0.025mm) to $\pm 0.005''$ (0.127mm) depending on material thickness and application.

Water-jet cutting is ideal for short-run part production, just-in-time manufacturing and prototype development. The accurate and smooth finish it gives you virtually eliminates the need for secondary machining.

In addition, we also have tilt-head capability which can produce components with a perfectly square, cut edge.

Why choose Water-jet?

- Cuts virtually any material.
- Achieves accurate burr-free components, eliminating the need for secondary finishing processes.
- Processes materials from 0.1mm up to 200mm thick.
- Accurate to ± 0.1 mm
- An economic cold cutting process
- No stress or heat affected zone
- Close nesting of parts to reduce material waste



Cutting Capability

Klinger's Omax 80160 and 60120 water-jet cutters can be used to cut the following material:

- Armour plate
- Carbon steel
- Stainless steels
- Tool steel
- Aluminium
- Nickel & nickel based alloys
- Copper & copper based alloys
- Titanium
- Rare earth metals
- Carbon-fibre composites
- Laminates
- Glass-reinforced plastic
- Plastics
- Granite, stone & marble
- Ceramic tiles
- Foam rubber & plastics
- And many more





Klinger Ltd. acquired C.N.Hadley Ltd. the world renowned slip and spectacle plate manufacturer. This venture brings together 80 years experience of Hadley Ltd. with Klinger's 130 years experience in the chemical and petrochemical industries. Using advanced equipment including plasma and water-jet cutting with CNC machinery we are able to offer the following products:

- Spectacle Plates
- Slip Plates and Rings
- Plate and Blank Flanges
- Special Flanges
- Machined Components
- Shims

Manufactured to suit either standard sizes or custom specifications. Faces can be machined to raised face or ring type joint profiles, and are commonly manufactured in accordance with API 590, ICI, BP, Shell or Texaco specification.

Available in:

- Carbon Steel
- Stainless Steel 304, 304L, 316L, 321

All available in short delivery times.



Plate Flanges and Blanks

Profile cut flanges from plate to British, American, European and Japanese standards and also customers own requirements.

Available in:

- Carbon Steel
- Chrome-Molybdenum Alloys
- Stainless Steel 304, 304L, 316L, 321
- Aluminium

Nominal Bore:

- From 10mm to 2200mm

Thickness:

- Up to 200mm – Carbon steel
- Up to 100mm – stainless steel

Also available:

- Hot-dip galvanising
- Electroplating
- Heat treatment

Current customers include:

- BP
- Shell
- ICI
- Kvaerner
- Dupont



Klinger Precision

To service the ever expanding high pressure and subsea sealing applications, Klinger has invested heavily in Klinger Precision increasing capacity for the UK manufacture of Ring Type Joints to ASME B16.20 and API 6A. The state of the art specialised machining centre helps to achieve production of exotic alloys and for emergency manufacture for the offshore oil and gas industries.

Machined & Profile Components

In addition to standard flanges and plate we can also manufacture complex profiled and machined components using the following techniques:

- Profile cutting with CAD
- General machining
- Milling
- Turning
- Drilling
- Tapping
- Screw-cutting
- Welding
- Wire-cut EDM (Electric Discharge Machining)





Klinger supply a comprehensive range of jointing to suit boiler door joints, man-hole, hand-hole and mud-hole gaskets in both standard and custom sizes. There are many application specific factors that can affect service life, so it is always advisable to consult Klinger for installation and service information.

Klinger Type 300/C-2

A high pressure, high temperature solution for man-hole, hand-hole and head gaskets. Manufactured from 3 mm pure expanded graphite reinforced with tanged stainless steel inserts, the gaskets are highly compressible and adaptable. This ensures a high-integrity seal is quickly achieved and will readily conform to non-uniform surfaces. In addition, Klinger 300/C-2 products are non-hardening, contain no fillers or binders, vulcanising rubbers or fibres to hydrolyse. This means that there is no temperature or stress relaxation after installation. Type 300/C-2 gaskets have excellent pressure and temperature resistance containing only graphite and stainless steel component parts. The gaskets have an excellent pH range (1-14) and are resistant to steam up to 60 bar and 450°C. Other thicknesses available on request.

Prekev

Prekev joints are manufactured from woven synthetic fibre proofed with rubber and stainless steel wire reinforced. Supplied with or without a graphite finish the material has good heat resistant qualities; the fibres do not melt, as they do not contain supporting organic fibres like viscose, etc. Prekev does not cause skin irritation, is very easy to sew and stick and has a very good mechanical tearing and abrasion resistance. Since Prekev contains natural rubber there is an elasticity reduction at a service temperature of 90°C. However the material can be used to 180°C and maximum pressure of 35 Bar.

TOPOG-E®

TOPOG-E® gaskets are moulded from a special, proprietary black, 80-85 Durometer rubber, designed to stop leakage that causes corrosion around handholes and manholes in steam boilers, water heaters and air tanks.

TOPOG-E® gasket are sufficiently compressible to fill any surface irregularities. They are moulded to fit any shape opening and conform to the configuration of both surfaces.

TOPOG-E® gaskets are specifically formulated to have excellent resistance to steam and hot and cold water. They also have good resistance to alcohols, ketones, phosphate esters, silicone oils and greases, dilute acids, bases, salts, glycols, ammonia, selected refrigerants, and animal and vegetable fats.

They can resist steam pressures up to 180psi, and temperatures to 190°C for an average service life of one year. When operating under less severe conditions (e.g. water applications at ambient temperatures) TOPOG-E® gaskets can provide very long service lives. There are many application specific factors that can affect service life, it is always advisable to first test TOPOG-E® gaskets in a particular application to determine their ultimate suitability.

Webbing and ladder tapes are suited for high temperature, low pressure applications where poor flanges or low bolt loadings are present. Typical applications are for ductwork flange gasketing, furnace / boiler door seals and cable and pipe protection.

Ceramic fibre woven webbing and ladder tapes are manufactured from high performance ceramic fibre yarns reinforced with either a wire or glass filament. Ceramic fibre yarns are produced on traditional textile machinery by carding high purity 1260°C ceramic fibres with a small percentage of cellulose fibre to assist in the processing. The yarns are then spun and combined with the relevant reinforcing media to improve the tensile strength at extended temperatures. The organic content will burn off at temperatures above 200°C without affecting the properties of the ceramic fibre but adequate ventilation should be provided during this initial heating. Where tensile strength is important the temperature limitations of the reinforcing media should be considered.

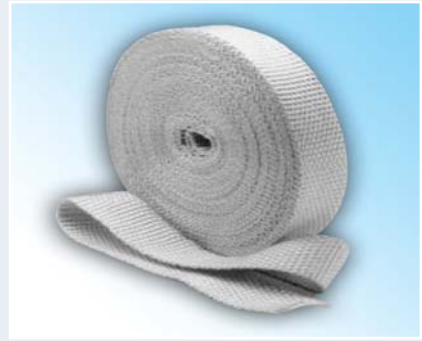

General Properties

Suitable for ductwork flange gasketing, furnace / boiler door seals and cable and pipe protection

- Ceramic fibres are non combustible
- Excellent chemical resistance
- Suitable for temperatures up to 1260°C (max temp of material dependent on reinforcement)

Reinforcement Temperature Limitations:

- Glass filament suitable up to 550°C
- Nickel Chrome wire Suitable up to 1090°C

Ceramic fibres are resistant to oils, solvents and most chemicals. However contact with phosphoric, hydrofluoric acids and strong alkalis should be avoided.

Availability

15mm - 100mm wide x 3mm thick coils
25mm - 100mm wide x 6mm thick coils

STAINLESS STEEL FLEXIBLE HOSES

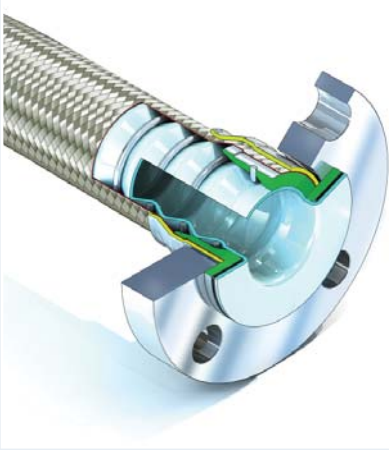

Critical to fluid transfer within petrochemical, food and pharmaceutical industries, Klinger now offer bespoke steel braided PTFE lined hose manufacturing facilities. Capable of withstanding temperatures up to 230°C, pressures and vacuums whilst remaining chemically resistant to corrosives and most aggressive media, Klinger's PTFE lined hose offers excellent performance whilst assuring end users an unparalleled level of safety over an increased service life. Each hose is custom built to your requirements with bore dimensions from ¼" to 6" in diameter, and a range of lined and non-lined connection options ranging from swivel flange, camlock, triclover, NPT and BSPT fittings.

Properties

- Good corrosion characteristics.
- Will convey wide variety of liquids and gases
- Can be manufactured with a smooth bore to prevent buildup of material in the convolutions and decrease turbulence and as a result increase fluid flow.

Availability

End fittings options include flanges, Triclover, cam-action and threaded fittings.



HOW SAFE IS YOUR PLANT ?

In a time when end users increasingly rely on contract labourers with little or no gasket experience, it is extremely important that the products you are using at your facility are of the highest quality.



Which one are you getting ?



**Off Brand
Spiral Wound
Gasket**

“Off brand” manufacturers through lack of knowledge, do not adhere to requirements of the standards

or do your gaskets comply with ASME B16.20



☞ Klinger Ltd. UK products meet all industry standards for quality to ASME B16.20 and are backed by the most knowledgeable technical staff in the industry



Bradford Head Office

*Klinger Ltd.
The Klinger Building
Wharfedale Road
Euroway Trading Estate
Bradford BD4 6SG
Tel: +44 (0) 1274 688 222
Fax: +44 (0) 1274 688 549
Email: sales@klingeruk.co.uk*



Projects

*The Klinger Building
Wharfedale Road
Euroway Trading Estate
Bradford BD4 6SG
Tel: +44 (0) 1274 688 222
Fax: +44 (0) 1274 688 962
Email: projects@klingeruk.co.uk*

International

*The Klinger Building
Wharfedale Road
Euroway Trading Estate
Bradford BD4 6SG
Tel: +44 (0) 1274 688 222
Fax: +44 (0) 1274 688 962
Email: international@klingeruk.co.uk*

Aberdeen

*Unit 31
South Wellheads Centre
Wellheads Crescent
Dyce
Aberdeen AB21 7GA
Tel: +44 (0) 1224 772 962
Fax: +44 (0) 1224 772 953
Email: aberdeen@klingeruk.co.uk*

Runcorn

*Unit 21
Dewar Court
Astmoor Industrial Estate
Runcorn
Cheshire WA7 1PT
Tel: +44 (0) 1928 577 030
Fax: +44 (0) 1928 575 223
Email: runcorn@klingeruk.co.uk*

Immingham

*Unit 2
Manby Road Industrial Estate
Immingham
North East Lincolnshire
DN40 2LF
Tel: +44 (0) 8449 676 778
Fax: +44 (0) 8449 676 779
Email: immingham@klingeruk.co.uk*

Southampton

*Unit 16
Parham Drive
Boyatt Wood
Eastleigh
Hampshire SO50 4NU
Tel: +44 (0) 2380 611 855
Fax: +44 (0) 2380 610 360
Email: southampton@klingeruk.co.uk*

Grangemouth

*Unit A
Block 2
West Mains Industrial Estate
Grangemouth FK3 8YE
Tel: +44 (0) 1324 472 231
Fax: +44 (0) 1324 482 111
Email: grangemouth@klingeruk.co.uk
acorn@klingeruk.co.uk*

Middlesbrough

*Klinger Unit
Drake Court
Britannia Park
Middlesbrough TS2 1RS
Tel: +44 (0) 1642 220 289
Fax: +44 (0) 1642 220 290
Email: boro@klingeruk.co.uk
hadleys@klingeruk.co.uk*